

T.O. 31R2-2URC-121

TECHNICAL MANUAL

**OPERATION AND MAINTENANCE INSTRUCTIONS
WITH ILLUSTRATED PARTS BREAKDOWN
(ORGANIZATIONAL/INTERMEDIATE)**

**RADIO FREQUENCY AMPLIFIER,
AM7224/URC, P/N 10087-0000**

**BASIC AND ALL CHANGES
HAVE BEEN MERGED TO MAKE
THIS A COMPLETE PUBLICATION**

DISTRIBUTION STATEMENT B - Distribution authorized to US Government agencies only for administrative or operational use (22 June 1995). Other requests for this document shall be referred to Sacramento ALC/TILBA, 3200 Peacekeeper Way, Suite 1, McClellan AFB CA 95652-1026.

HANDLING AND DESTRUCTION NOTICE - Handle in compliance with distribution statement and destroy by any method that will prevent disclosure of the contents or reconstruction of the document.

Published under authority of the Secretary of the Air Force

23 JULY 1985

CHANGE 3 - 22 JUNE 1995

LIST OF EFFECTIVE PAGES

NOTE: The portion of the text affected by the changes is indicated by a vertical line in the outer margins of the page. Changes to illustrations are indicated by miniature pointing hands. Changes to wiring diagrams are indicated by shaded areas.

Dates of issue for original and changed pages are:

Original 0 23 Jul 85
 Change 1 1 Oct 90
 Change 2 26 Sep 91
 Change 3 22 Jun 95

TOTAL NUMBER OF PAGES IN THIS PUBLICATION IS 142, CONSISTING OF THE FOLLOWING:

Page No.	*Change No.	Page No.	*Change No.	Page No.	*Change No.
Title	3	FP-10 Blank	0		
A	3	FP-11	0		
i - xi	0	FP-12 Blank	0		
1-0 - 1-8	0				
1-9 - 1-10	1				
1-11	0				
1-12	1				
2-1 - 2-14	0				
3-1 - 3-5	0				
3-6 Blank	0				
4-1 - 4-7	0				
4-8 Blank	0				
5-1 - 5-16	0				
6-1 - 6-3	0				
6-4	1				
6-5 - 6-6	0				
6-7	1				
6-8 - 6-30	0				
6-31	3				
6-32 - 6-34	0				
6-35	1				
6-36 - 6-37	0				
6-38	2				
6-38.1 Added	2				
6-38.2 Blank Added	2				
6-39 - 6-46	0				
7-1 - 7-6	0				
7-7	2				
7-8 - 7-10	0				
8-1	0				
8-2 Blank	0				
FP-1	0				
FP-2 Blank	0				
FP-3	0				
FP-4 Blank	0				
FP-5	0				
FP-6 Blank	0				
FP-7	0				
FP-8 Blank	0				
FP-9	0				

*Zero in this column indicates an original page

SAFETY SUMMARY

The following are general safety precautions that are not related to any specific procedures and therefore do not appear elsewhere in this publication. These are recommended precautions that personnel must understand and apply during many phases of operation and maintenance.

KEEP AWAY FROM LIVE CIRCUITS

Operating personnel must at all times observe all safety regulations. Do not replace components with the power supplies turned on. Under certain conditions, dangerous potentials may exist when the power control is in the off position, due to charges retained by capacitors. To avoid casualties, always remove power and discharge circuits to ground before touching any circuit components. Remove watches and rings before performing any maintenance procedures.

DO NOT SERVICE OR ADJUST ALONE

Under no circumstances should any person reach into or enter the enclosure for the purpose of servicing or adjusting the equipment except in the presence of someone who is capable of rendering aid.

RESUSCITATION

Personnel working with or near high voltages should be familiar with modern methods of resuscitation. Cardiopulmonary resuscitation procedures are outlined in T.O. 31-1-141-1, and annual refresher training requirements are outlined in AFOSH STD 127-50.

The following warnings appear in the text in this volume, and are repeated here for emphasis.

WARNING

Improper grounding of the 1 KW LPA equipment can cause HIGH VOLTAGE dangerous to life to be present on the equipment chassis in the event of a malfunction.

WARNING

Avoid breathing fumes generated by soldering. Eye protection is required.

WARNING

Voltages dangerous to life exist in this radio equipment. Before removing the top cover, disconnect the primary power and wait 30 seconds. This allows time for all voltages to bleed off.

HANDLING OF ELECTROSTATIC DISCHARGE SENSITIVE DEVICES (ESDS)

Electrostatic Discharge Sensitive Devices (ESDS) must be handled with certain precautions that must be followed to minimize the effect of static build-up. Consult T.O. 00-25-234, DOD Std-1686, and DOD HDBK 263. ESDS devices are identified in this technical order by the following symbol.



TABLE OF CONTENTS

Section/Para	Page
CHAPTER 1. GENERAL INFORMATION	
1-1. General Description and Purpose.....	1-1
1-2. Equipment Functional Description.....	1-1
1-3. Mechanical Design.....	1-3
1-4. Leading Particulars.....	1-3
1-5. Capabilities and Limitations.....	1-3
1-6. Equipment and Accessories Supplied.....	1-3
1-7. Equipment Required but not Supplied.....	1-3
1-8. Special Tools and Test Equipment.....	1-3
1-9. Related Publications.....	1-3
CHAPTER 2. INSTALLATION	
I INSTALLATION LOGISTICS	
2-1. Equipment Unpacking Procedure.....	2-1
2-2. Preparation for Installation.....	2-1
2-3. Site Consideration.....	2-3
II INSTALLATION PROCEDURE	
2-4. Installing the Equipment.....	2-6
2-5. 1KW LPA Stack Mounting Instructions.....	2-6
2-6. 1KW LPA Rack Mounting Instructions.....	2-6
2-7. Cabling Connections.....	2-6
2-8. Checking the Installation.....	2-14
CHAPTER 3. PREPARATION FOR USE AND RESHIPMENT	
I PREPARATION FOR USE	
3-1. Initial Control Settings.....	3-1
3-2. Initial Power Application.....	3-1
3-3. Step-By-Step Sequence for Initial Power Application.....	3-1
3-4. Step-By-Step Sequence for Manual Built-In Test Procedure.....	3-2
3-5. Step-By-Step Sequence for Automatic Built-In Test Procedure.....	3-2
3-6. Initial Checkout.....	3-3
3-7. Step-By-Step Sequence for Manual Turning Procedure.....	3-3
3-8. Step-By-Step Sequence for Automatic Turning Procedure.....	3-3
II PREPARATION FOR RESHIPMENT	
3-9. Preparation for Reshipment.....	3-5
3-10. Step-By-Step Disassembly Procedure.....	3-5
3-11. Step-By-Step Packing and Crating Procedure.....	3-5

TABLE OF CONTENTS (Continued)

Section/Para		Page
	CHAPTER 4. OPERATION	
I	CONTROLS AND INDICATORS	
	4-1. Control and Indicator Descriptions.....	4-1
	4-2. Front Panel Controls.....	4-1
	4-3. Operating Controls.....	4-1
II	OPERATING INSTRUCTIONS	
	4-4. Introduction.....	4-4
	4-5. Operating Sequence.....	4-4
	4-6. Power-Up.....	4-4
	4-7. Warm-Up.....	4-4
	4-8. Basic Function Operation.....	4-4
	4-9. Transceiver Controlled Operations.....	4-5
	4-10. Microprocessor Controlled Operations.....	4-5
	CHAPTER 5. THEORY OF OPERATION	
	5-1. Introduction.....	5-1
	5-2. Functional Assemblies.....	5-1
	5-3. RF Signal Processing.....	5-1
	5-4. Power Control Subgroup.....	5-4
	5-5. Microprocessor Control.....	5-4
	5-6. Support Function Group.....	5-4
	5-7. Detailed Discussions.....	5-4
	5-8. Tube Assembly A1.....	5-4
	5-9. Tank Assembly A2.....	5-6
	5-10. VSWR/XFMR PWB Assembly A3.....	5-8
	5-11. Fan Inverter PWB Assembly A4.....	5-9
	5-12. Power Control PWB Assembly A5.....	5-11
	5-13. Micro Control PWB Assembly A6.....	5-14
	5-14. Front Panel Assembly A7.....	5-15
	5-15. Temperature Sensor PWB Assembly A8.....	5-16
	5-16. Interconnect PWB Assembly A9.....	5-16
	5-17. Low Pass Filter Assembly A10.....	5-16
	CHAPTER 6. MAINTENANCE	
I	INTRODUCTION	
	6-1. Chapter Organization.....	6-1
	6-2. On-Equipment Maintenance Philosophy.....	6-1
	6-3. BIT (Built-In Test).....	6-1

TABLE OF CONTENTS (Continued)

Section/Para	Page
II	PERFORMANCE TESTING AND TROUBLE ANALYSIS USING BIT
6-4.	Front Panel Controls and Displays..... 6-2
6-5.	Periodic Automatic Status Checking..... 6-2
6-6.	Manual Diagnostic BIT Routine..... 6-3
6-7.	Automatic Diagnostic BIT Routine..... 6-3
6-8.	Troubleshooting with BIT..... 6-3
III	REMOVAL/REPLACEMENT PROCEDURES
6-9.	Tube Assy..... 6-30
6-10.	Tank Assy..... 6-30
6-11.	VSWR/XFMR PWB Assy..... 6-30
6-12.	Fan Inverter PWB Assy..... 6-31
6-13.	Power Control PWB Assy..... 6-31
6-14.	Micro Control PWB Assy..... 6-31
6-15.	Front Panel PWB Assy..... 6-33
6-16.	Temp Sensor PWB Assy..... 6-33
6-17.	Interconnect PWB Assy..... 6-33
6-18.	Low Pass Filter Assy..... 6-33
6-20.	Air Filter..... 6-33
IV	PERIODIC MAINTENANCE PROCEDURES
6-21.	Periodic Maintenance Actions..... 6-35
V	ALIGNMENT PROCEDURES
6-22.	Introduction..... 6-36
6-23.	Alignment Procedures..... 6-36

CHAPTER 7. ILLUSTRATED PARTS BREAKDOWN

I	INTRODUCTION
7-1.	Purpose..... 7-1
7-2.	Scope..... 7-1
7-3.	Chapter Organization..... 7-1
7-4.	Source, Maintenance, and Recoverability (SMR) Codes..... 7-1
7-5.	Federal Supply Codes for Manufacturers (FSCM)..... 7-1
II	MAINTENANCE PARTS LIST

CHAPTER 8. FOLDOUT DRAWINGS

LIST OF ILLUSTRATIONS

Figure		Page
CHAPTER 1. GENERAL INFORMATION		
1-1	Radio Frequency Amplifier AM-7224/URC	1-0
1-2	Simplified Functional Diagram	1-2
1-3	Identification of Subassemblies	1-4
CHAPTER 2. INSTALLATION		
2-1	Unpacking the Equipment	2-1
2-2	Basic Equipment Configuration	2-3
2-3	Typical Stack-Mount Installation	2-5
2-4	Dimensions	2-7
2-5	Rear Panel Connector Locations	2-8
2-6	Multipin Connector Assembly	2-9
2-7	Coaxial Connector Assembly	2-11
2-8	Safety Precautions for Fabrication of Cables	2-12
CHAPTER 3. PREPARATION FOR USE AND RESHIPMENT		
3-1	Manual Tune Chart	3-4
CHAPTER 4. OPERATION		
4-1	1KW LPA, Operating Controls and Indicators	4-2
CHAPTER 5. THEORY OF OPERATION		
5-1	Functional Block Diagram	5-2
5-2	Support Function Block Diagram	5-3
5-3	Bias and IK Limit Control	5-5
5-4	S1C Selected Output Inductor Sections	5-7
5-5	Z Transformation Simplified Diagram	5-10
CHAPTER 6. MAINTENANCE		
6-1	Manual Diagnostic BIT Routine	6-8
6-2	Flowchart A	6-11
6-3	Flowchart B	6-13
6-4	Flowchart C	6-14
6-5	Flowchart D	6-15
6-6	Flowchart for Fault Code 2-03	6-17
6-7	Flowchart for Fault Code 2-04	6-19
6-8	Flowchart for Fault Code 2-05	6-20
6-9	Flowchart for Fault Code 2-08	6-21
6-10	Flowchart for Fault Code 2-09	6-23
6-11	Flowchart for Fault Code 2-10	6-24
6-12	Flowchart for Fault Code 2-11	6-25
6-13	Flowchart for Fault Code 2-13	6-26
6-14	Flowchart for Fault Code 2-14	6-27
6-15	Flowchart for Fault Code 2-15	6-28

LIST OF ILLUSTRATIONS (Continued)

Figure		Page
6-16	Flowchart for Fault Code 2-16	6-29
6-17	Power Control PWB Assy	6-32
6-18	1 KW LPA	6-41
6-19	Power Control PWB Assy Simplified	6-42
6-20	VSRW/XFMR PWB Assy Simplified	6-43
6-21	Temp Sensor PWB Assy Simplified	6-44

CHAPTER 7. ILLUSTRATED PARTS BREAKDOWN

7-1	1 KW LPA, AM-7224/URC, Front View	7-4
7-2	1 KW LPA, AM-7224/URC, Exploded View	7-6
7-3	Installation Kit for 1 KW LPA	7-8

CHAPTER 8. FOLDOUT DRAWINGS

FO-1.	Family Tree 1 KW LPA.....	FP-1
FO-2.	Power Control PWB Simplified.....	FP-3
FO-3.	Component Location Diagram.....	FP-7
FO-4.	Interconnection Diagram.....	FP-9

LIST OF TABLES

Table		Page
CHAPTER 1. GENERAL INFORMATION		
1-1	Leading Particulars.....	1-6
1-2	Capabilities and Limitations.....	1-7
1-3	Equipment and Accessories Supplied.....	1-10
1-4	Equipment Required But Not Supplied.....	1-11
1-5	Optional Equipment.....	1-12
1-6	Related Publications.....	1-12
CHAPTER 2. INSTALLATION		
2-1	Interconnection Cabling Information.....	2-13
CHAPTER 3. PREPARATION FOR USE AND RESHIPMENT		
3-1	Initial Control Settings.....	3-1
CHAPTER 4. OPERATION		
4-1	1 KW LPA, Operating Controls and Indicators.....	4-1
4-2	Meter Display Reading.....	4-6
CHAPTER 6. MAINTENANCE		
6-1	Meter Functions and Normal Operating Ranges.....	6-4
6-2	Fault Code Chart.....	6-6
6-3	Test Equipment.....	6-36

GLOSSARY

A	Ampere(s)
A/D	Analog-to-Digital (Converter)
AFSK	Audio frequency shift keying; a baseband modulation scheme in which two audio frequencies are used to represent binary coded data; the frequency is shifted to one frequency to represent a 1 (mark) and to the other to represent a 0 (space).
AGC	Automatic gain control
ALE	Address latch enable
AM	Amplitude modulation; a modulation scheme in which the carrier is made to vary in amplitude in accordance with the modulating signal.
AME	Amplitude modulation equivalent
ANTIVOX	Prevents false VOX operation; see VOX
BFO	Beat Frequency Oscillator, used in SSB detection circuits
BIT	Built-in Test
BIU	Bus interface unit
BW	Bandwidth
CPU	Central processing unit
CREV	Converter reverse
CW	Continuous wave; a wave that does not vary in amplitude or frequency and is turned on and off to carry intelligence, e.g., Morse Code
D/A	Digital-to-Analog (Converter)
dB	Decibel(s)
dBm	Decibel(s) relative to one milliwatt
EMI	Electromagnetic interference
EPROM	Erasable programmable read-only memory
EU	Execution unit
HF	High frequency; a radio frequency band extending from about 3 MHz to 30 MHz; in this manual, HF includes 1.6 to 30 MHz.
HV	High voltage
IF	Intermediate frequency
IM	Intermodulation (distortion)
I/O	Input/Output
KREV	Keyer reverse
LCD	Liquid crystal display
LED	Light emitting diode
LPA	Linear power amplifier
LSB	Lower sideband; a modulation scheme in which the intelligence is carried on the first sideband below the carrier frequency; see SSB
MIC	Microphone
mA	Milliampere(s)
mV	Millivolt(s)
NBSV	Narrow band secure voice
PEP	Peak envelope power
PPC	Peak power control
PWB	Printed wiring board
RAM	Random access memory
rms	Root mean square
RTC	Real time clock
RX	Receive

GLOSSARY (Cont.d)

S TONE	Sidetone
SSB	Single sideband; a modulation scheme in which the intelligence is carried by one of the carrier sidebands, the other sideband and the carrier center frequency being suppressed
TGC	Transmitter gain control
TX	Transmit
uA	Microampere(s)
uP	Microprocessor
USB	Upper sideband; a modulation scheme in which the intelligence is carried on the first sideband above the carrier frequency; see SSB
uV	Microvolt(s)
Vac	Volts, alternating current
VCO	Voltage controlled oscillator
Vdc	Volts, direct current
VOX	Voice operated transmission
VSWR	Voltage standing wave ratio; the ratio of the maximum to the minimum voltage of a standing wave on a radio frequency transmission line
W	Watt(s)

INTRODUCTION

The purpose of this on-equipment level manual is to provide all information necessary for the installation, operation and on-equipment maintenance of Amplifier, Radio Frequency, AM-7224/URC, manufactured by the RF Communications Group of Harris Corporation, Rochester, New York. The manual is divided into eight chapters. The contents of each chapter are briefly described in the following paragraphs.

Chapter 1 provides a general description and a list of capabilities and limitations of the Amplifier, Radio Frequency, AM-7224/URC. A list of companion equipment references are included along with the components that form the AM-7224/URC.

Chapter 2 provides the information necessary for planning and carrying out the installation of the Amplifier, Radio Frequency, AM-7224/URC. A dimensional outline drawing is provided to show dimensions and other information required for proper installation.

Chapter 3 provides instructions for preparing the Amplifier, Radio Frequency, AM-7224/URC for use, including the initial application of power and checkout. Instructions for repacking the equipment for reshipment are also included in Chapter 3.

Chapter 4 provides complete operating instructions for the Amplifier, Radio Frequency, AM-7224/URC in all modes and contains a list of operating controls and indicators.

Chapter 5 provides a complete theory of operation for the Amplifier, Radio Frequency, AM-7224/URC. An overall theory and detailed theory of individual functional circuits are provided.

Chapter 6 describes the on-equipment location maintenance procedures. On-equipment location maintenance is based on the use of built-in test (BIT) features of the equipment to isolate problems to the replaceable subassembly or printed wiring board (PWB) level. Depot maintenance is supplied in a separate publication, T.O. 31R2-2URC-123. The Depot Manual is based on performance testing and trouble analysis of the subassembly or PWB to locate and replace faulty parts at the lowest replaceable unit level (LRU).

Chapter 7 contains the Illustrated Parts Breakdown (IPB) information at the on-equipment level. This includes assemblies and parts that may be replaced at the on-equipment location.

Chapter 8 contains all fold-out (FO) drawings. A cross reference list is provided as well as the individual drawings referenced throughout chapters 1 to 7. The diagrams are numbered FO-1, FO-2, etc. They are printed on sheets with page-size blank aprons to permit viewing the diagram with the rest of the book closed or opened to another page.

APPLICABLE SPECIFICATIONS

The following specifications, standards, and publications were used in the preparation of this manual.

SPECIFICATION	NAME
MIL-M-38798B, para. 3.4	Combined Operation and Maintenance Instructions Manual (Equipment).
MIL-M-38807, Amend. 4	Preparation of Illustrated Parts Breakdown.
MIL-M-38790 and MIL-M-38784A	General Requirements for Preparation of Technical Manuals.

APPLICABLE STANDARDS

STANDARD	NAME
MIL-STD-12	Abbreviations for use on Drawings and in Technical Type Publications.
MIL-STD-15-1A	Graphic Symbols for Electrical Components.
MIL-STD-17-1	Mechanical Symbols.
MIL-STD-806	Graphic Symbols for Logic Diagrams.

APPLICABLE PUBLICATIONS

PUBLICATION	NAME
DOD 5200.20	Distribution Statements on Technical Documents.
USAS Y14.15-1966	Electrical and Electronic Diagrams.
USAS Y32.16-1968	Electrical and Electronic Reference Designations.
T.O. 31-1-141 (Series)	Technical Manual-Basic Electronic Technology and Testing Practices.

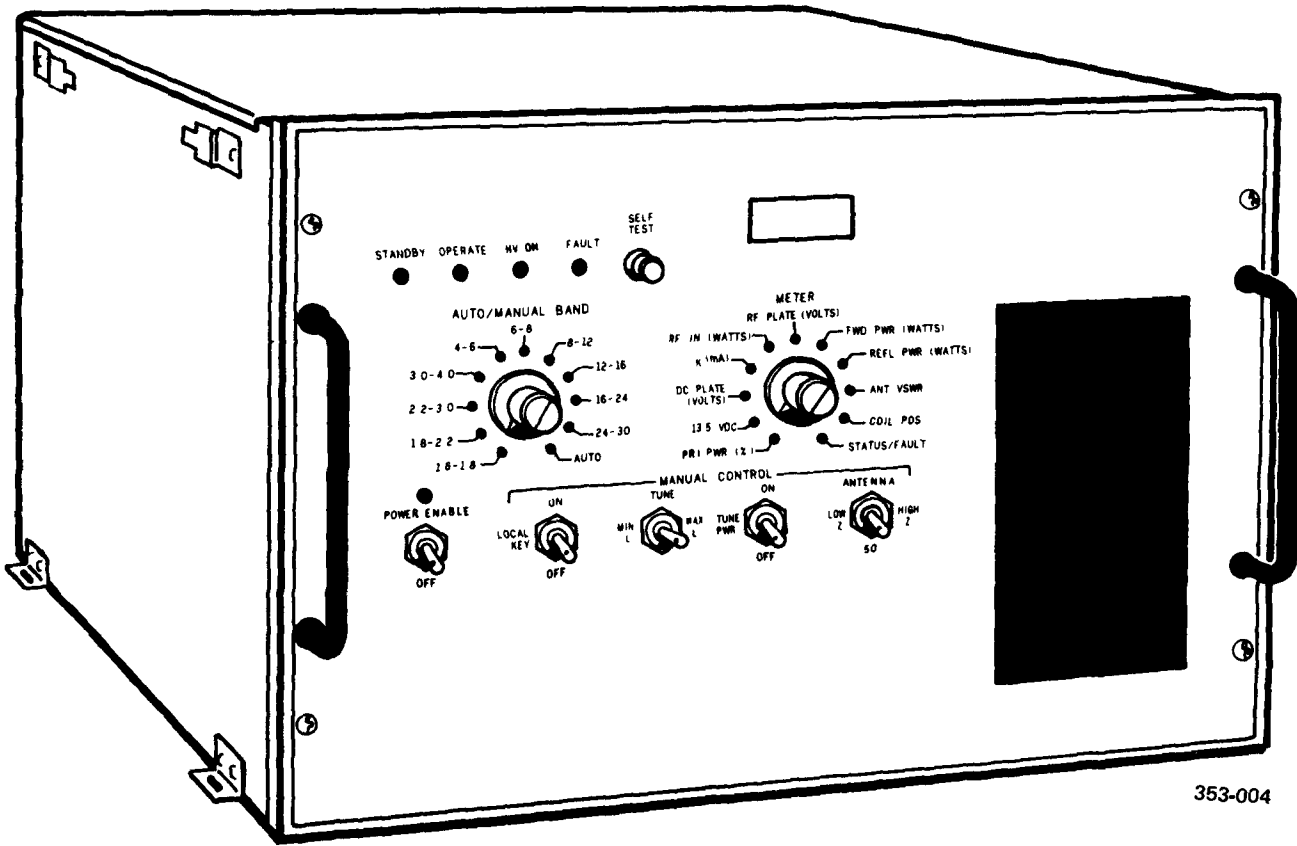

353-004

Figure 1-1. Radio Frequency Amplifier AM-7224/URC

CHAPTER 1

GENERAL INFORMATION

1-1. GENERAL DESCRIPTION AND PURPOSE. Radio Frequency Amplifier AM-7224/URC, shown in figure 1-1, and hereafter known as 1 KW LPA, is a microprocessor controlled power amplifier that amplifies the selected HF (high frequency) input signal from a 100 Watt Transceiver in the frequency range of 1.6 to 30 MHz. The output level delivered by the 1 KW LPA is 1000 watts PEP (peak envelope power) with multiple tone input signals, or 1000 watts average with lock keyed CW or a continuous single tone input signal. The 1 KW LPA tunes automatically in response to frequency data from the 100 Watt Transceiver and to its own internally generated fine tuning (servo) signals. Automatic tuning is accomplished in 10 seconds or less. The 1 KW LPA can also be tuned manually, using front panel controls.

a. Applications. The 1 KW LPA is used in applications where the 100 watt output of the 100 Watt Transceiver is not sufficient to provide for the desired level of communication. Built-in test (BIT) features provide fault indications in response to a test routine initiated either at the 100 Watt Transceiver, (in automatic mode), or at the 1KW LPA front panel in the manual mode. Fault indications are sent to the 100 Watt Transceiver for display as fault codes that aid in localizing malfunctions to the problem areas in the 1KW LPA.

b. Power Requirements. The 1KW LPA requires three externally supplied operating voltages: +3000 Vdc B+ for the grounded grid amplifier, 115 Vac filament voltage for the amplifier, and +13.5 Vdc for all general support circuit functions, and one sample voltage for biasing of the grounded grid amplifier. A separate power supply within the 1KW LPA converts a part of the +13.5 Vdc input to 115 Vac @ 400 Hz for the high efficiency fan.

c. Reliability. The 1 KW LPA is designed for continuous operation under severe environmental conditions. It is intended for fixed station applications. Automatic sensing circuits protect the LPA from damage due to overdriving, abnormal tuning, or high VSWR, including open or short circuit conditions, high and low line voltages, insufficient air flow, and/or overtemperature.

1-2. EQUIPMENT FUNCTIONAL DESCRIPTION. Figure 1-2 is a simplified functional diagram used to support the following discussion.

a. Signal Paths. Control, tuning, and support logic for the 1 KW LPA, including 100 Watt Transceiver interface data and parameters from Front Panel Assembly A7, are administered by Microprocessor Control PWB Assembly A6. Frequency information is sent to the LPA from the 100 Watt Transceiver upon initiation of a keyline command after a frequency change greater than 1%. This information is read by the microprocessor, which generates a bandswitch code that is applied through the Servo/Bandswitch Drive PWB Assembly A2A7 to an open-seeking bandswitch wafer. The microprocessor also determines the required direction of rotation of the tuning inductor to reach a pre-tune position and issues a MIN L or MAX L direction command to the coil servo. When both the inductor and the bandswitch have arrived at the pre-tune positions, the microprocessor initiates a fine tune sequence. This sequence is accomplished by calling for tune power from the 100 Watt Transceiver and monitoring the RF Plate voltage while adjusting the variable inductor slowly. When fine tuning has been completed, the 1 KW LPA informs the 100 Watt Transceiver that the PA Operate mode is established.

b. Outputs.

(1) In the transmit mode, the XCVR RF signal is routed by the T/R Relay on the VSWR/XFMR PWB Assembly A3 to Tube Assembly A1 where it is amplified. The RF signal then passes through tuned 1 KW Tank Assembly A2 to the impedance select circuit on VSWR/XFMR PWB Assembly A3. The RF signal is applied through a VSWR Bridge circuit on the VSWR/XFMR PWB Assembly to the Low Pass Filter Assembly A10 and to the ANTENNA connector J5 of the 1 KW LPA.

(2) In the receive mode, the RF signal from ANTENNA connector J5 is routed through the Low Pass Filter Assembly A10 to the XCVR RF connector J3 via the T/R Relay on the VSWR/XFMR PWB Assembly A3.

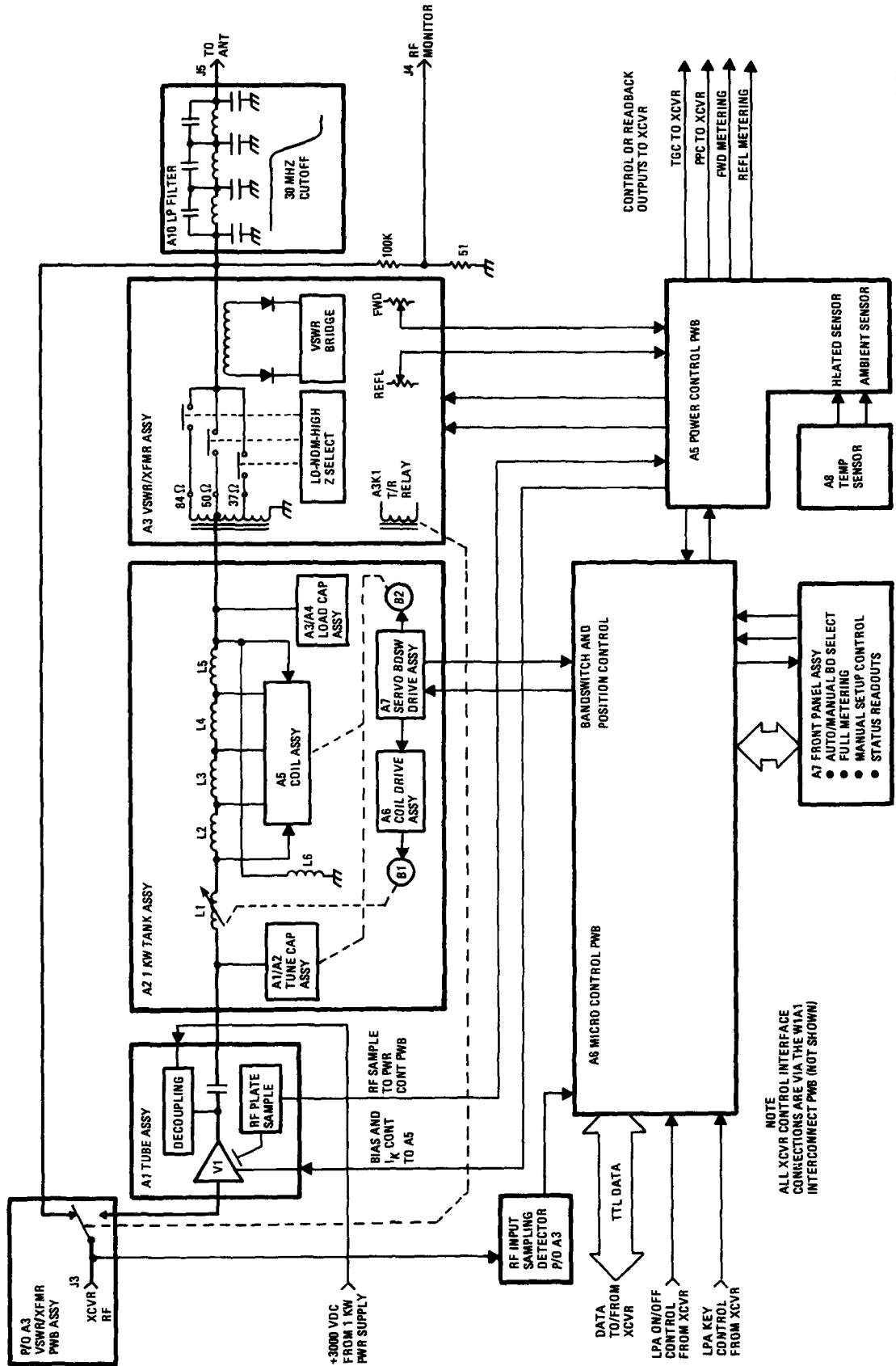

363-002

Figure 1-2. Simplified Functional Diagram

1-3. MECHANICAL DESIGN. The mechanical construction of the 1 KW LPA is shown in figure 1-3. The unit consists of one major assembly with 11 subassemblies. The major assembly is 1KW LPA Chassis Assembly A1 which contains all of the subassemblies. The 11 subassemblies are: Tube PWB Assembly A1, Tank Assembly A2, VSWR/XFMR PWB Assembly A3, Fan Inverter PWB Assembly A4, Power Control PWB Assembly A5, Microprocessor Control PWB Assembly A6, Front Panel Assembly A7, Temperature Sensor PWB Assembly A8, Interconnect PWB Assembly A9, Low Pass Filter Assembly A10, and Fan Assembly B1. The tunable components of the 1 KW LPA are located in Tank Assembly A2. The top cover of the chassis assembly is removable so that all other assemblies are accessible for removal or maintenance.

1-4. LEADING PARTICULARS. The characteristics of the 1 KW LPA are summarized in table 1-1. This table includes physical data and operating/storage environment data.

1-5. CAPABILITIES AND LIMITATIONS. The capabilities and limitations of the 1 KW LPA are described in table 1-2.

1-6. EQUIPMENT AND ACCESSORIES SUPPLIED. Table 1-3 lists the assemblies, components, units, cables, and accessory kits supplied with the 1 KW LPA.

1-7. EQUIPMENT REQUIRED BUT NOT SUPPLIED. Table 1-4 lists equipment required, but not supplied, for the installation and operation of the 1 KW LPA. It is specifically designed to interface with the equipment listed in table 1-4.

1-8. SPECIAL TOOLS AND TEST EQUIPMENT. The servicing and maintenance of the 1 KW LPA do not require any special tools, test jigs, or fixtures. All on-equipment maintenance uses the BIT feature, and replacement of indicated assemblies is completed with common hand tools, e.g., screwdriver, etc. Refer to the Depot Manual for a list of test equipment used to service this equipment at the Depot level.

1-9. RELATED PUBLICATIONS. Table 1-6 lists the technical order publications related to use of the 1 KW LPA.

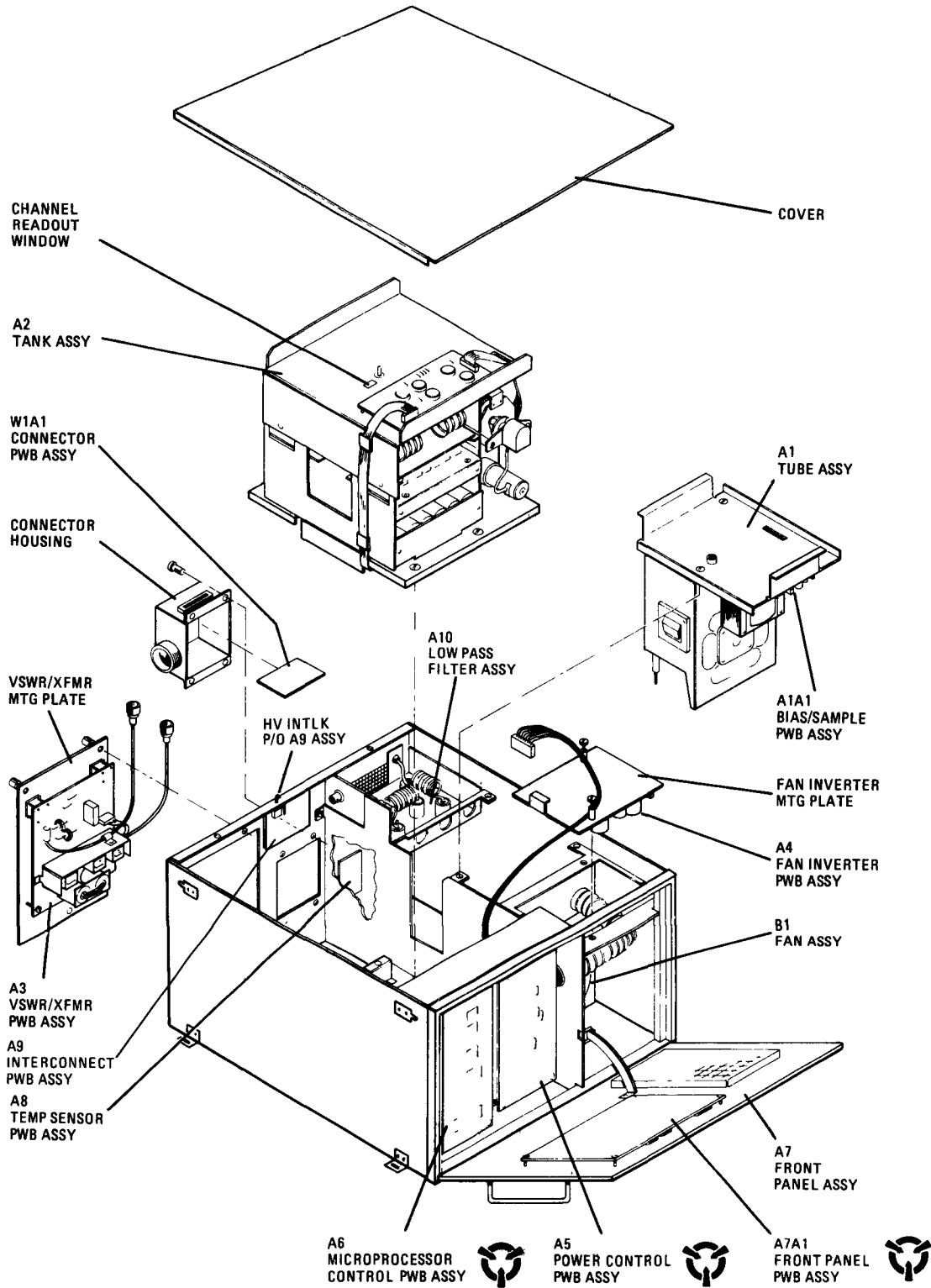

353 006

Figure 1-3. Identification of Subassemblies

Table 1-1. Leading Particulars

Item	Characteristic Or Value
Dimensions: Height: Width: Depth:	10.50 inches (26.60 cm) 16.75 inches (42.54 cm) 20.00 inches (50.80 cm)
Weight:	40.00 pounds (18.18 kg) Crated weight is approximately 55.00 pounds (25.00 kg)
Mounting:	Rack or stack
Power Requirements:	Input Power with Power Supply PP-7913/URC: 115/208/230 Vac + 10%, single phase, at 50 to 400 Hz, 40/20/18 A maximum
Operating Environment:	Temperature: -30°C to +50°C Relative Humidity: 10% to 95% (non-condensing)
Storage Environment:	Temperature: -35°C to +70°C Relative Humidity: 10% to 95% (non-condensing)
Operating Altitude:	10,000 feet above mean-sea-level (MSL)
Transport Altitude:	40,000 feet above MSL
Shock/Vibration:	MIL-STD-810C
Cooling:	Convection and forced air (built-in fan)

Table 1-1. Leading Particulars (Continued)

Item	Characteristic Or Value
Cabling Requirements:	Rear Panel Connections J1 - PA-PS CONTROL J2 - XCVR CONTROL A3J3 - XCVR RF A3J4 - RF MONITOR A10J5 - ANTENNA
Transportability:	Manual methods apply
Setup Time:	Less than 1 hour

Table 1-2. Capabilities and Limitations

Description Of Characteristic	
Use:	Signal amplification from 100 watts to 1 KW between the 100 Watt Transceiver and the 1 KW Antenna Coupler (i.e., between Receiver-Transmitter, Radio RT-1446/URC and Antenna Coupler AN/URA-38().
Frequency Range and Tuning Capability:	1.6 to 30 MHz in AUTO or in ten MANUAL bands: Band 1 - 1.6 to 1.8 MHz Band 2 - 1.8 to 2.2 MHz Band 3 - 2.2 to 3.0 MHz Band 4 - 3.0 to 4.0 MHz Band 5 - 4.0 to 6.0 MHz Band 6 - 6.0 to 8.0 MHz Band 7 - 8.0 to 12.0 MHz Band 8 - 12.0 to 16.0 MHz Band 9 - 16.0 to 24.0 MHz Band 10 - 24.0 to 30.0 MHz
RF Drive Power Required:	65 watts for full power output

Table 1-2. Capabilities and Limitations (Continued)

Description Of Characteristic	
Maximum Rated RF Bypass Power:	100 watts average or 100 watts PEP
Maximum Rated RF Output Power:	With Power Supply PP-7913/URC 1000 watts continuous average power with a single-tone or CW input signal; 1000 watts PEP when loaded with two tones driven by the 100 Watt Transceiver.
Tuning Mode:	Automatic with Manual tuning backup. Automatic Tune Time - 10 seconds, Maximum.
Metering:	Forward power, reflected power, cathode current, DC plate voltage, RF plate voltage, VSWR, RF input power, 13.5 Vdc, and primary power
Channel Change Time:	5 seconds nominal
Nominal Output Impedance:	50 ohms
Working VSWR:	2:1 (self-protecting for any load)
Intermodulation Distortion:	Third order harmonic more than 33 dB down from the rated PEP output of two equal tones.
Harmonic Output:	More than 40 dB down
Features:	RF Protection Circuits protect the LPA from overdriving or abnormal tuning and from abnormal VSWR, including the condition of a short or open circuit. Automatic receive capability is available in unkeyed state. 1KW LPA can be remotely controlled from the 100 Watt Transceiver. Tests points and metering facilitate operation and maintenance. This unit provides high/low line protection and protection from overtemperature and low air flow conditions.

Table 1-2. Capabilities and Limitations (Continued)

Description Of Characteristic	
Primary Power Requirements:	115/208/230 Vac 170 W, standby (single phase) 425 W, operate (unkeyed) 3200 W, operate (keyed, 1 KW avg. power out)
Remote Capability:	100 feet (30.5 M) separation (maximum) between 100 Watt Transceiver and the 1 KW LPA 6 feet (1.83 M) separation (typical) between 1 KW LPA and 1 KW Power Supply 250 feet (76.2 M) separation (typical) between 1 KW LPA and 1 KW Antenna Coupler
Control Lines: (J1)	PWR ON : +13.5 Vdc H.V. ON : GND Filament : 115 Vac Filament : 115 Vac PWR ON Ret. : GND +13.5 Vdc : +13.5 Vdc B+ Sample : 0 - +30 Vdc +3000 Vdc : +3000 Vdc
Control Lines: (J2)	PPC - : GND PPC + : 5.6 volts (Threshold) TGC - : GND TGC + : 0 volts to 8 volts V REFLD : 4 volts = 1KW V FWD : 4 volts = 1KW LPA ON/OFF : 13.5 volts = ON RF MUTE : 0 volts = MUTE LPA KEY : 0 volts = KEYED DATA - : GND DATA + : 0 volts to 5 volts LPA ID : GND
Transceiver Interfaces:	RF coaxial cable and a 19-wire control cable (14 active and 5 spares)

Table 1-2. Capabilities and Limitations (Continued)

Description of Characteristic	
Antenna Coupler Interface:	RF coaxial cable
Tune Power Requirements:	20 to 40 watts carrier

Table 1-3. Equipment and Accessories Supplied

Qty	Item	Use
1	Amplifier, Radio Frequency AM-7224/URC	Amplify 100 Watt Transceiver output to 1KW

Table 1-4. Equipment Required But Not Supplied*

Qty	Item	Description
1	100 Watt Transceiver RT-1446/URC.	Companion equipment used for reception and transmission of RF signals.
1	Power Supply PP-7913/URC	Companion equipment used to supply high voltage to the 1 KW LPA.
1	Antenna	Required for reception and transmission of radio signals.
1 drop per screw	Loctite. #262 (Red)	Used to secure screws holding front panel handles.
1 drop per screw	Loctite. #222 (Violet)	Used to secure mounting screws for Connector PWB Assy and Low Pass Filter PWB Assy.

Table 1-4. Equipment Required But Not Supplied*

Qty	Item	Description
1	Ancillary Kit, 10087-0060, consisting of items listed below	Provides mounting hardware and interface connectors.
1	Connector, Receptacle 25 Pin 17-80250-16	Mates with J2 on rear of 1 KW LPA
1	Connector, Pins, 25 Pin, DBM25P	Mates with J8 on back of 100 Watt Transceiver
2	Hood, D Connector 25 Pos. 745173-2	Used with J22-0001-001 and J22-0001-002
2	Ferrule J55-0015-901	Used with J22-0001-001 and J22-0001-002
2	Connector, Pins, 12 Pin, 10087-0016	Mates with J1 on the back of the 1 KW LPA and the 1 KW Power Supply
2	Clamp, Cable J08-0002-243	Used with 10087-0016
4	Bracket, Stacking 10087-3106	Used with the 1 KW LPA
8	Post, Stacking 10087-3107	Used with the 1 KW LPA and the 1 KW Power Supply
1	Technical Manual TO 31R2-2URC-121	Contains installation and main- tenance procedures for the 1 KW LPA

* See table 6-3 for required test equipment.

Table 1-5. Optional Equipment

Qty	Item	Description
1	Remote Control Unit C-11329/URC	Companion equipment used where it is desired to operate the 100 Watt Transceiver from a remote location.
1	Coupler, Antenna AN/URA-38 ()	Companion equipment used to match the 1 KW LPA to the antenna system.

Table 1-6. Related Publications

Title	Publication No.
100/500 Watt Antenna Coupler, CU-2310/URC On-Equipment Manual Depot Manual Work Cards	TO 31R2-2URC-111 TO 31R2-2URC-113 TO 31R2-2URC-116WC-1
Receiver-Transmitter, Radio, RT-1446/URC On-Equipment Manual Depot Manual Work Cards	TO 31R2-2URC-81 TO 31R2-2URC-83 TO 31R2-2URC-86WC-1
Amplifier, Radio Frequency, AM-7223/URC On-Equipment Manual Depot Manual Work Cards	TO 31R2-2URC-101 TO 31R2-2URC-103 TO 31R2-2URC-106WC-1
Power Supply, PP-7913/URC On-Equipment Manual Depot Manual Work Cards	TO 35C1-2-892-1 TO 35C1-2-892-3 TO 35C1-2-892-6WC-1
Amplifier, Radio Frequency, AM-7224/URC On-Equipment Manual Depot Manual Work Cards	TO 31R2-2URC-121 TO 31R2-2URC-123 TO 35C1-2-892-6WC-1
Remote Control Unit, C-11329/URC On-Equipment Manual Depot Manual Work Cards	TO 31R2-2URC-91 TO 31R2-2URC-93 TO 31R2-2URC-96WC-1
Overall System Work Cards	TO 31R2-2URC-126WC-1
1KW Antenna Coupler Group, AN/URA-38A RF601 DR-525	TO 31R2-2URA38-1 TO 31R2-2TSC38-82 TO 31S1-4-228-1

CHAPTER 2

INSTALLATION

WARNING

Dangerous voltages exist in this radio equipment.
Before removing any covers, disconnect primary power.

Section I. INSTALLATION LOGISTICS

2-1. EQUIPMENT UNPACKING PROCEDURE. The 1KW LPA is packed in a corrugated cardboard box for shipment. A two-piece foam enclosure protects the equipment from rough handling.

a. When the unit is received, carefully inspect the exterior of the box. Look for any damage, signs of rough handling or weather exposure (e.g., water damage) or signs that the box may have been tampered with. If any of these conditions are present, carefully note and report them to the proper authority (refer to T.O. 00-35D-54). An external sticker on the shipping box provides additional instructions concerning inspection of the package.

b. Refer to figure 2-1 for instructions concerning unpacking the box. The box consists of double-walled cardboard with reinforced strapping tape. A sharp knife is required to open the box. Use the knife carefully to avoid injury. Keep the packing box in a secure place for possible future use.

c. After removing the equipment from the box, use the packing list in the ancillary package to verify the presence of each item in the shipment. Any shortages of items should be reported to the proper authority (refer to T.O. 00-35D-54).

d. The boxed equipment weighs a total of approximately 55 pounds. Use normal care to move the boxed equipment into the general location where it is to be installed. Once unpacked, the 1KW LPA weighs a total of 40 pounds and may be handled by one individual.

2-2. PREPARATION FOR INSTALLATION. Site selection is the most important consideration in

preparing for installation of the equipment. Details for site selection will vary depending on the use of the 1KW LPA.

2-3. SITE CONSIDERATION. A number of factors should be considered, from security to operational requirements, and it is the responsibility of the user to determine which has precedence. Each of the following items should be considered in site selection:

a. Power Source. Power requirements identified in table 1-1 should be observed (see chapter 1 of this manual).

b. Loading. Depending on the installation method, be sure the selected space has adequate strength to support the weight of the equipment plus the weight of the associated 1KW Power Supply PP-7913/URC, which is approximately 175 pounds total.

c. Accessibility. Consider the space needed for access to the equipment for servicing, operating, and maintenance.

d. Transceiver Interface. Be sure the maximum length of the 1KW LPA control cable does not exceed 100 feet, and that the maximum distance between the 1KW LPA and the antenna coupler does not exceed 250 feet.

e. System Ground. Make sure the system is properly grounded for safety (e.g., lightning hazard) (refer to T.O. 31-10-24).

f. Environment. The 1KW LPA will operate normally over an ambient temperature range of -30°C to +50°C.

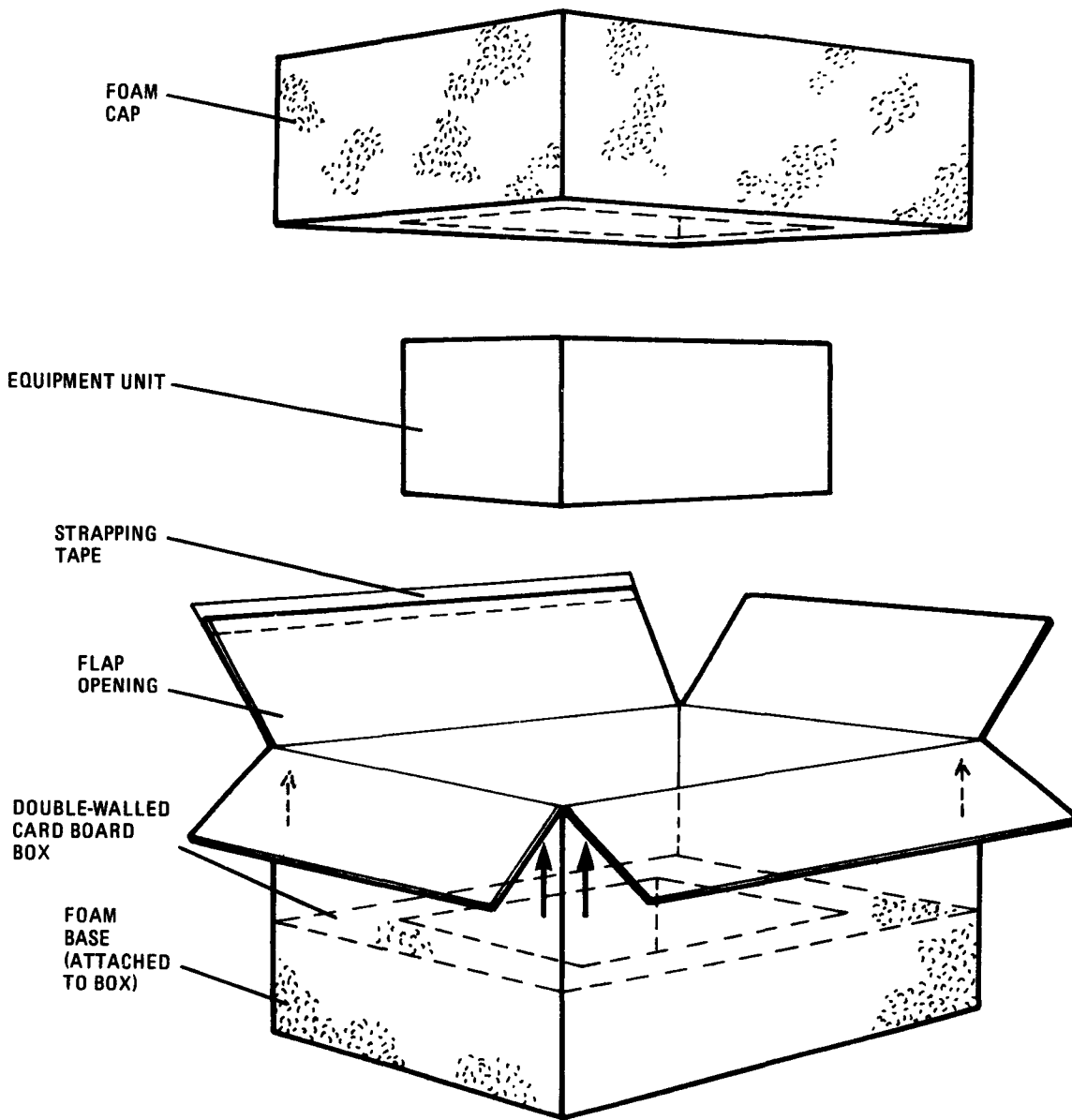

UNPACKING PROCEDURE

1. PLACE BOX ON FLOOR WITH ARROWS MARKED ON EACH SIDE POINTING UP.
2. CUT TAPE ON TOP OF BOX AND REMOVE FOAM CAP FROM BOX.
3. LIFT EQUIPMENT UNIT OUT OF BOX.
4. SAVE BOX AND FOAM CAP FOR RESHIPMENT.

350-003

Figure 2-1. Unpacking the Equipment

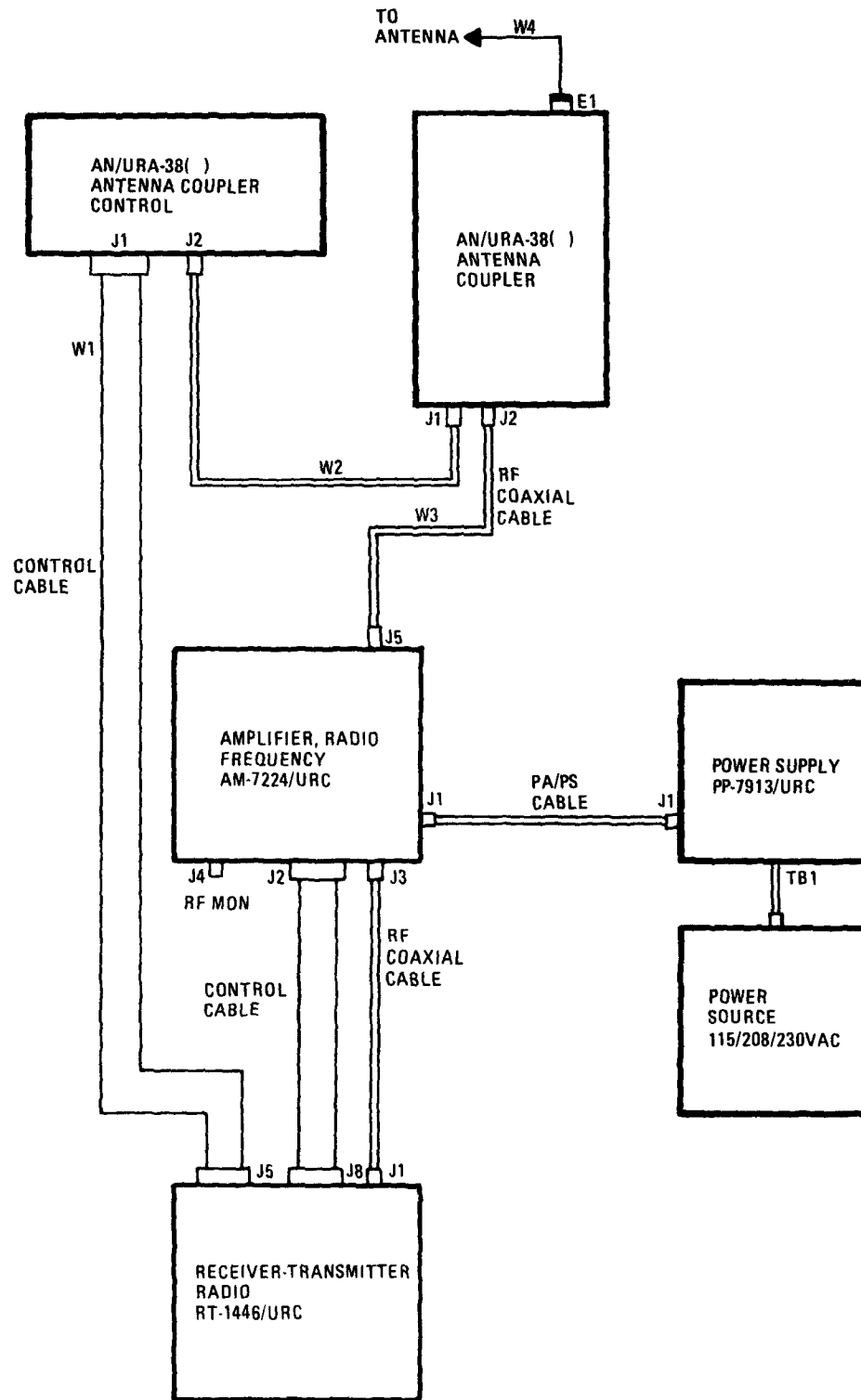

353 008A

Figure 2-2. Basic Equipment Configuration

T.O. 31R2-2URC-121

g. Interaction. All control interfaces are RF filtered to minimize interaction with other electronic equipment.

h. Heat Dissipation. Cooling in the 1KW LPA is accomplished by convection and forced air (built-in fan). Provide sufficient space for cooling air to enter and exhaust from the unit.

i. Servicing. Allow for space to store any replacement assemblies, servicing tools, and test equipment.

j. Companion Equipment. Since the 1KW LPA is to be operated in conjunction with some of the companion equipment identified in table 1-4 (see chapter 1 of this manual), additional considerations may be required as identified in the companion equipment manuals.

k. Mounting. Once the site has been selected, the method of mounting the equipment should be considered. Each mounting method requires a particular type of mounting hardware. The mounting holes at the sides of the equipment can be used for slide mounts, brackets, posts, etc., depending on the manner of installation. Most installations of the equipment will result in one of the mounting techniques described in the following paragraphs.

l. Installation Configuration. Figure 2-2 shows the basic equipment configuration in the 1KW LPA site installation. The 1KW LPA is connected between the 100 Watt Transceiver and the AN/URA-38() Antenna Coupler in the RF line. While both the 1KW LPA and

the AN/URA-38() Antenna Coupler have their own control interfaces with the 100 Watt Transceiver, the 1KW LPA interfaces with the 1KW Power Supply via the PA-PS control cable.

m. Grounding. Proper grounding of the 1KW LPA is recommended to prevent possible serious personnel hazards in the event of equipment malfunctions. Refer to T.O. 31-10-24. A good ground is 10 ohms or less.

WARNING

Improper grounding of the 1KW LPA equipment can cause HIGH VOLTAGE dangerous to life to be present on the equipment chassis in the event of a malfunction.

The ground straps should be constructed of wide copper strap or braid, and should be as short as possible. Ground straps should be clamped and bonded to a cold water pipe or other metal conductor that provides a good ground.

n. Typical 1KW LPA Installation. Cable type and installation precautions for this type of 1 KW LPA installation are basically the same as for an installation where an antenna coupler is not used. A typical stack mount 1KW LPA installation is shown in figure 2-3.

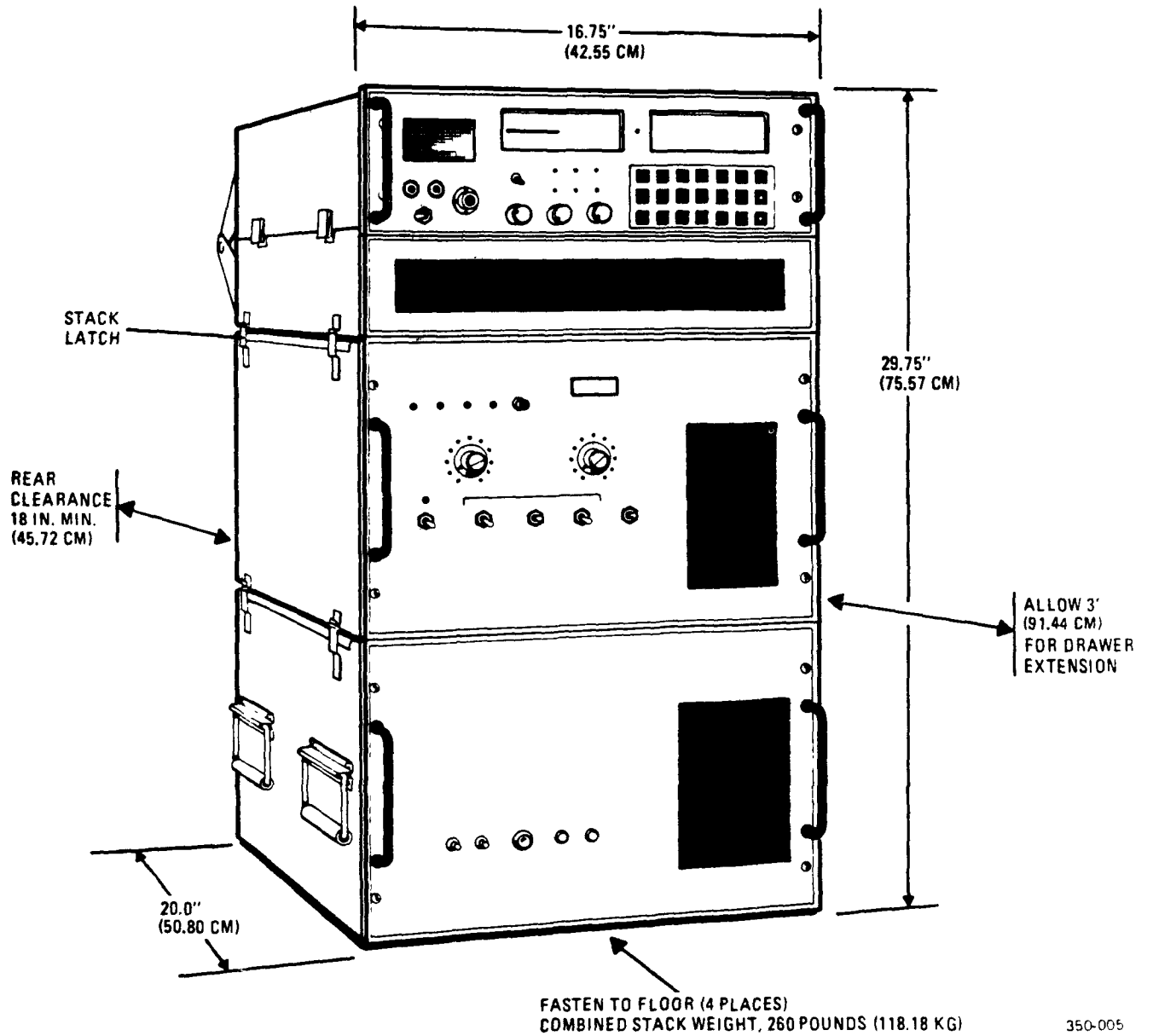

Figure 2-3. Typical Stack-Mount Installation

Section II. INSTALLATION PROCEDURE

2-4. INSTALLING THE EQUIPMENT. After unpacking the equipment and selecting the site, install the 1KW LPA as described in the following paragraphs.

a. Time Requirements. Installation should not take more than one hour regardless of the equipment configuration, not including the time necessary to install an antenna or any companion equipment, or to fabricate cables.

b. Tool Requirements. Installation is accomplished with common hand tools; e.g., socket wrenches, screwdrivers, pliers, etc.

c. Personnel Requirements. Equipment positioning requires one individual to lift and place the unit in position (two individuals are required to lift and place the 1 KW Power Supply in position). Once the equipment is positioned and secured, one person can complete the installation in approximately 30 minutes.

2-5. 1KW LPA STACK MOUNTING INSTRUCTIONS

a. Refer to table 1-1 for the 1KW LPA dimensions. Figure 2-4 illustrates these dimensions. Make sure that the mounting surface allows adequate room for ventilation intakes and outlets, and has proper clearance for cable interconnection.

b. Install the stack mounting brackets and mounting post, using the hardware provided in the ancillary kit and the screw holes provided in the chassis of the 1KW LPA.

c. Secure the 1KW LPA to the mounting surface, using appropriate hardware.

2-6. 1KW LPA RACK MOUNTING INSTRUCTIONS

a. Refer to table 1-1 for the 1KW LPA dimensions. Make sure that the mounting surface allows adequate room for ventilation intakes and outlets, and has proper clearance for cable interconnection.

b. Install slide mounting brackets and slides, using the appropriate hardware.

c. Carefully lift the LPA and insert the slides in the mounting rack slide brackets. Ensure that equipment is properly seated.

2-7. CABLING CONNECTIONS. After the equipment has been positioned and secured, fabricate and connect the 1KW LPA cables as described in the following paragraphs. Be sure the POWER ON/OFF switch is in the OFF position before connecting the equipment to any power source.

a. Interconnection and Interface. The user is responsible for fabrication of the cables. Refer to figure 2-2 for the identification of cables required for operation of the 1KW LPA. Figure 2-5 shows the locations of the rear panel connectors, and table 2-1 contains interconnection information.

b. Cable Fabrication. The fabrication of the control cable is shown in figure 2-6 (sheets 1, 2, and 3), and the fabrication of all RF coaxial cables is shown in figure 2-7.

CAUTION

High voltage wire must be a separate shielded wire rated at 20 KV as shown.

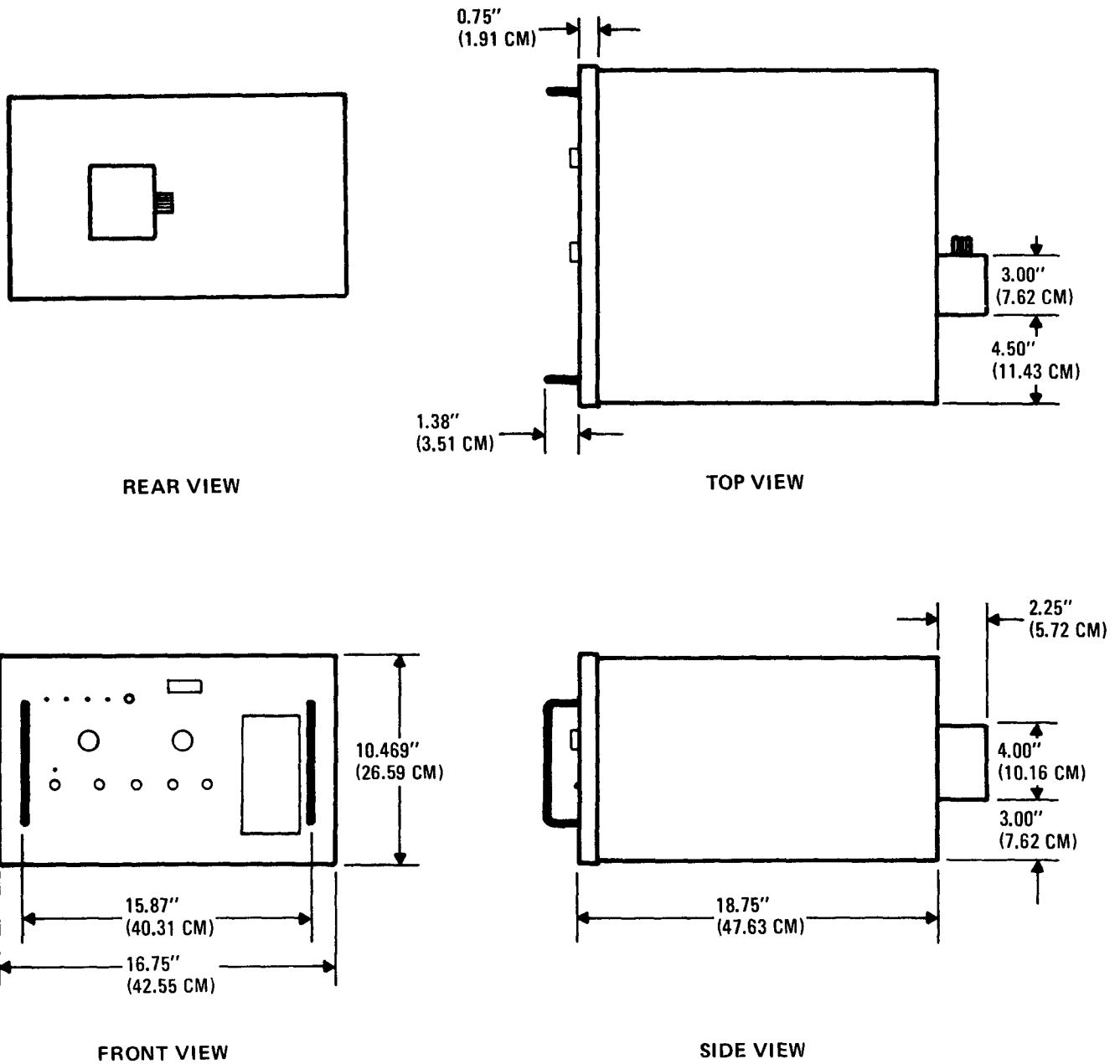

353 010

Figure 2-4. Dimensions

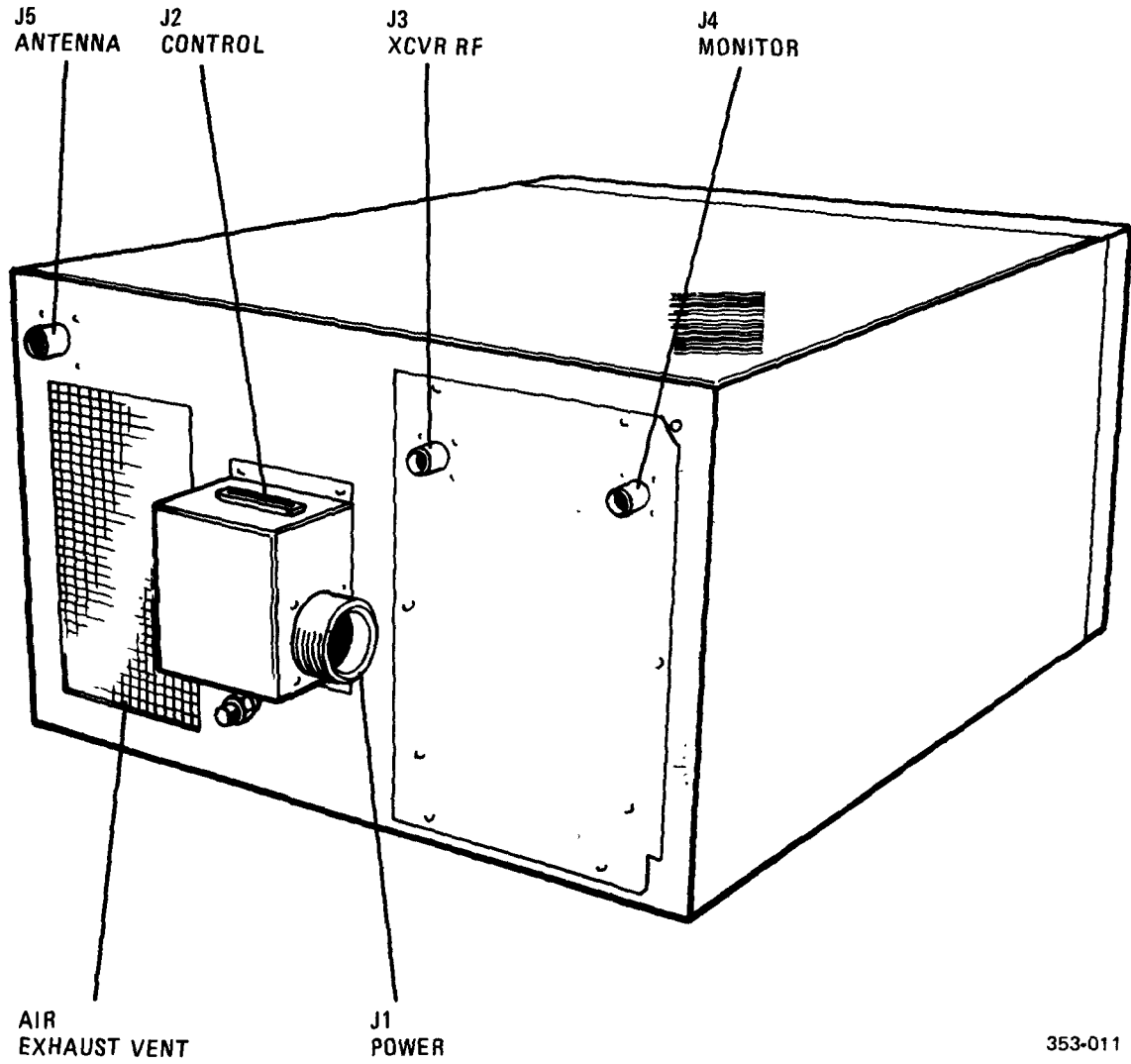

353-011

Figure 2-5. Rear Panel Connector Locations

STEP

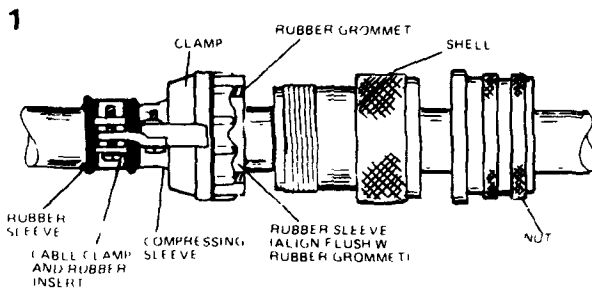

Install cable clamp and rubber insert, rubber sleeve clamp, compressing sleeve, rubber grommet, shell, and nut over cable. Assemble as shown. Leave cable clamp loose. Align rubber sleeve flush with rubber grommet inside clamp. Push assembly back out of the way to perform the steps shown below.

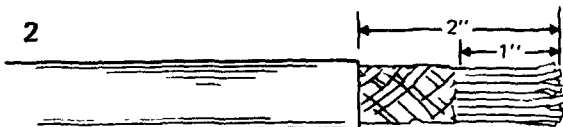

Remove 2" of vinyl jacket from cable as shown. Do not cut into shielding. Remove 1" of shielding as shown. Take care not to damage insulation on wires in cable bundle.

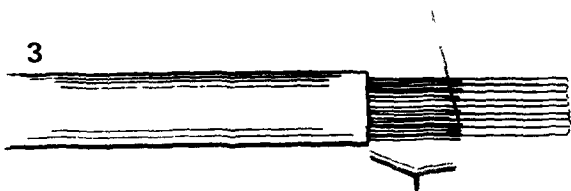

Carefully comb out shield wires as shown.

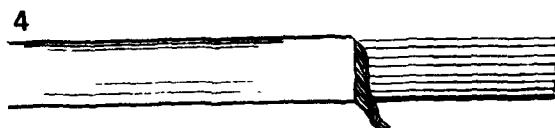

Make a part in the combed shield wires opposite the black wire in the cable. Pull the shield wires around both sides of the cable and twist together to make a pigtail as shown.

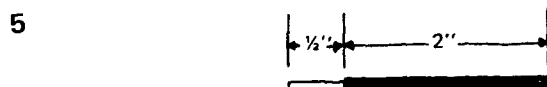

Remove 1/2" of insulation from a 2-1/2" length of No. 22 black stranded wire and tin.

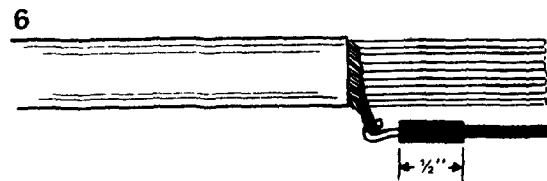

Twist the stripped end of black wire with the pigtail and solder. Cut 1/2" black shrink sleeving and install over soldered connection. Use a heat gun (an alternative is an open flame) to shrink sleeving exercising caution to avoid getting heat onto cable jacketed.

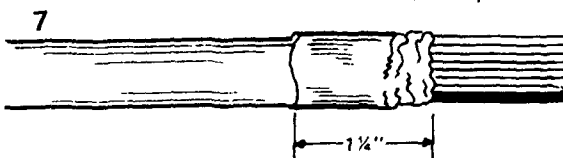

Install shrink sleeving over cable as shown -- apply heat and "shrink" in place. Use heat gun. If no heat gun is available use open flame. Avoid getting heat on cable jacket. Rotate cable for an even shrinkage.

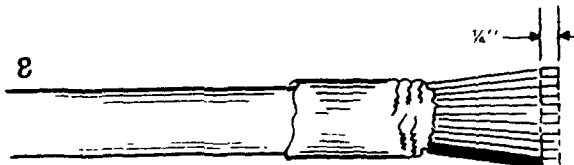

Remove 1/4" insulation from wires to be used

350-007

Figure 2-6. Multipin Connector Assembly (Sheet 1 of 3)

STEP

9.

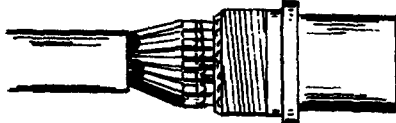

10.

Repeat assembly and soldering procedures for the other end of the cable.

11.

Check both ends of the cable for continuity, shorts between wires and shorts to the connector shell.

12.

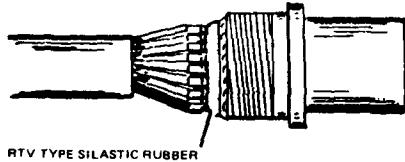

RTV TYPE SILASTIC RUBBER

13.

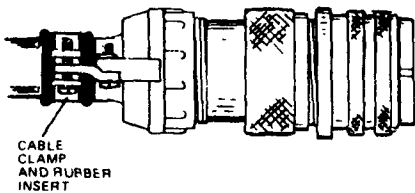

CABLE CLAMP AND RUBBER INSERT

Refer to Table 2-1 for interface connections. Twist and tin stripped wires together to form pairs as shown for cable lengths over 100 feet (30 meters). Twist and tin remaining stripped wires. Cut sleeving supplied in connector kits into 1/2 inch (1 1/4 cm) lengths and slide over each wire. Keep wires parallel as they come out of the cable bundle to the connector pins. Ensure the black wire installed in step 6 and the black wire in the cable are lined up with and soldered to pin D. Solder wires to the solder cups using Table 2-1. Slide sleeving over solder cups. Write down wire colors assigned to each pin number for reference when assembling the connector on the other end of the cable.

AJ3

Apply RTV type silastic rubber to a thickness of approximately 1/8 inch. Use small opening of nozzle to insure getting rubber between all solder caps. Use small, slender object such as a piece of wire or toothpick to insure a smooth, continuous waterseal.

Assemble the plug as shown. Assemble clamp as tightly as possible onto the shell to assure a watertight connection around the cable. Repeat watersealing and assembling of connector on other end of cable. After connector has been threaded onto Antenna Coupler case connector J2, wrap both connectors with several layers of plastic electrical tape as close to the Antenna Coupler case as possible. (For protection against corrosion of mating threads in wet or humid environments.)

NOTE: To convert inches to centimeters, multiply by 2.540.

350-008

Figure 2-6. Multipin Connector Assembly (Sheet 2 of 3)

WARNING

The following instructions must be followed exactly, since the LPA - Power Supply power cable contains high voltage (approximately 4000 Vdc).

SPECIAL INSTRUCTIONS FOR FABRICATION OF LPA – POWER SUPPLY POWER CABLE

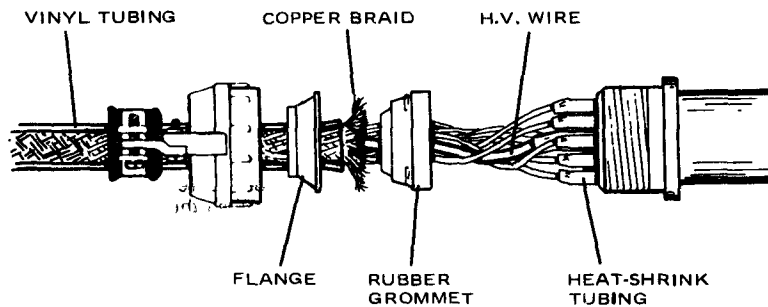

1. Select wire size and color according to the following chart:

PIN	WIRE SIZE	SUGGESTED COLOR
A	22	BROWN
B	22	RED
C	22	ORANGE
D	22	YELLOW
E *	18	WHT/RED
F *	18	WHT/ORG
G	18	BLACK
H	22	GREEN
J	16	BLACK
K	16	RED
L	22	WHT/BLK
M	18	WHITE
HIGH VOLTAGE (20 KV RATED MINIMUM), PART NO.: STYLE 3239 (FSCM: 03890)		

*115 VAC

2. Insert 3/16 inch heat-shrink tubing (approximately 1/2 inch) over both ends of all wires to be soldered.

3. Feed wires through tubular copper braid, approximately equal in length to wires. Part number: 2174 (FSCM: 92194).
4. Feed copper braid through clear vinyl tubing, approximately equal to braid in length. Part number: PVC-105/9/16 (FSCM: 92194).
5. Solder wires to terminals indicated on chart.
6. Slide heat-shrink tubing over solder connections and shrink into position with heat gun or match.
7. Ground braid wire to connector shells as follows:
 - a. Push braid through flange.
 - b. Fan braid over flange.
 - c. Compress braid and flange with rubber grommet.
8. Insert vinyl tubing through cable clamp, butt it against the flange, and tighten clamp.

353-041

Figure 2-6. Multipin Connector Assembly (Sheet 3 of 3)

STEP

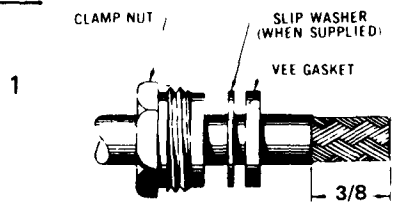

Cut cable end square, place clamp-nut, slip washer (when supplied), and gasket over jacket. Remove 3/8" of vinyl jacket.



Place braid clamp over braid against jacket cut. Comb out copper braid as shown.



Fold braid back over braid clamp and trim as shown. Cut off dielectric 3/16" from end. Tin center conductor.



Solder contact to center conductor. Avoid use of excessive heat. See that end of dielectric is clean. Contact must be flush against dielectric. Outside of contact must be free of solder.

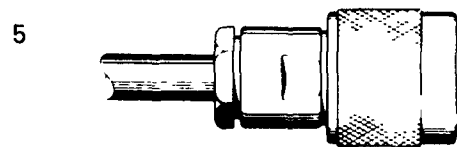

Thread assembly into connector, and lock securely. Vee gasket must be split by braid clamp.

350-009

Figure 2-7. Coaxial Connector Assembly

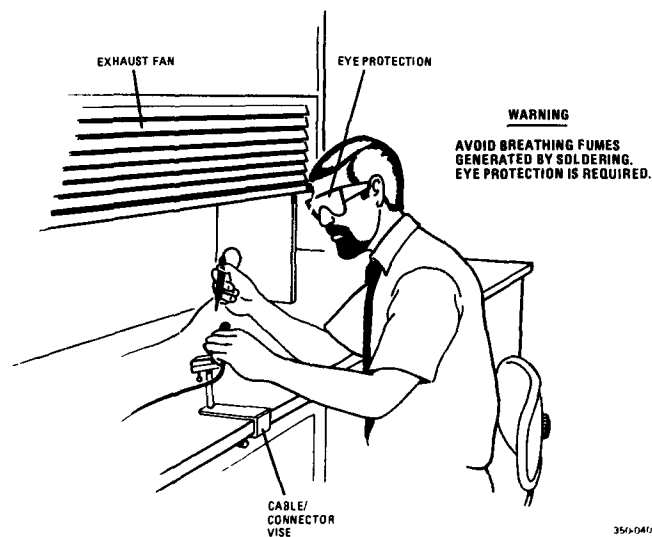

Figure 2-8. Safety Precautions for Fabrication of Cables

Table 2-1. Interconnection Cabling Information

J1 Power (LPA end) Mating connector: 10087-0016		J1 Power (Power Supply end) Mating connector: 10087-0016	
J1-A	Power-on Switch	J1-A	
J1-B	High Voltage On*	J1-B	
J1-C	Spare	J1-C	
J1-D	Spare	J1-D	
J1-E	115 VAC Filament	J1-E	
J1-F	115 VAC Filament	J1-F	
J1-G	Ground	J1-G	
J1-H	Power-on Return (Ground)	J1-H	
J1-J	Ground	J1-J	
J1-K	+13.5 Vdc	J1-K	
J1-L	B+ Sample	J1-L	
J1-M†	B+ 3000 Volts	J1-M	
J2 Control (LPA end) Mating connector: J22-0001-002 (female)		J8 Control (Transceiver end) Mating connector: J22-0001-001 (male)	
J2-1	PPC Ground	J8-1	
J2-2	TGC +	J8-2	
J2-3	Ground (VF, VR)	J8-3	
J2-4	Vfwd	J8-4	
J2-5	DATA +	J8-5	
J2-6	LPA Key	J8-6	
J2-7	LPA On/Off*	J8-7	
J2-8	Spare	J8-8	
J2-9	Ground	J8-9	
J2-10	Not Used	J8-10	
J2-11	Not Used	J8-11	
J2-12	Not Used	J8-12	
J2-13	Not Used	J8-13	
J2-14	PPC	J8-14	
J2-15	TGC -	J8-15	
J2-16	VREFL	J8-16	

* Indicates that the signal is active low. On schematic diagrams, active low signals have a bar over the top.

†Requires high voltage wire rated at 20 KV minimum.

Table 2-1. Interconnection Cabling Information (Continued)

J2-17	LPA ID*	J8-17	
J2-18	DATA -	J8-18	
J2-19	RF Mute*	J8-19	
J2-20	Spare	J8-20	
J2-21	Spare	J8-21	
J2-22	Ground	J8-22	
J2-23	Not Used	J8-23	
J2-24	Not Used	J8-24	
J2-25	Not Used	J8-25	
J3	XCVR RF (LPA end) Mating connector: M39012/01-0005 (coaxial) Cable type: RG-8/U (coaxial)	J1	XCVR RF (Transceiver end). Mating connector: M39012/01-0005 (coaxial) Cable type: RG-8/U (coaxial)
J4	RF Monitor (LPA end) Mating connector: KC-59-89 (coaxial) Cable type: RG-188 (coaxial)		
J5	Antenna (LPA end) Mating connector: M39012/01-0005 (coaxial) Cable type: RG-8/U (coaxial)	J2	Antenna (Coupler end) Mating connector: M39012/01-0005 (coaxial) Cable type: RG-8/U (coaxial)

2-8. CHECKING THE INSTALLATION. After the 1KW LPA has been installed and interconnection cables are connected, verify that each item in the list below has been completed before applying power. Power application and initial equipment testing are discussed in chapter 3 of this manual.

- a. All connectors are attached and tight.
- b. Ground wires are connected between the 1KW LPA and a known good ground. Examples of

good grounds are a cold water pipe, a long copper stake driven into solid earth, or a system ground bus at an existing site.

- c. Hardware for the equipment is properly tightened, and the equipment cannot be tipped or moved.
- d. Provisions are adequate for heat dissipation.
- e. Refer to chapter 3 for the proper power application procedures.

CHAPTER 3
PREPARATION FOR USE AND RESHIPMENT

Section I. PREPARATION FOR USE

3-1. INITIAL CONTROL SETTINGS. This section details the initial control settings prior to the application of power to the 1 KW LPA. These control settings are listed in table 3-1. Note that all controls are on the front panel of the 1 KW LPA; companion equipment controls will not be discussed. It is assumed that the 1 KW LPA is installed and correctly connected to a compatible, fully operational 100 Watt Transceiver and that the 1 KW LPA is correctly connected to a 1 KW Power Supply, as described in chapter 2 of this manual. If in doubt about the installation of the 1 KW LPA and the 1 KW Power Supply, verify the information in chapter 2 before proceeding.

3-2. INITIAL POWER APPLICATION. This portion of the manual provides a step-by-step sequence for the initial application of power to the 1 KW LPA. Upon completion of the listed steps, the operator will have confirmed that the 1 KW LPA is ready for the checkout test procedure that is found in paragraph 3-4.

3-3. STEP-BY-STEP SEQUENCE FOR INITIAL POWER APPLICATION.

- a. With the POWER ON/OFF switch set to the OFF position, complete any power application checks for the associated 100 Watt Transceiver as

Table 3-1. Initial Control Settings

Control	Initial Setting
1. POWER ON/OFF	Select OFF position.
2. LOCAL KEY ON/OFF	Select OFF position.
3. TUNE MIN L/MAX L	Spring loaded to center position (Neutral).
4. TUNE PWR ON/OFF	Select TUNE PWR OFF position.
5. ANTENNA	Select 50 OHM position.
6. AUTO/MANUAL BAND	Select AUTO position.
7. METER	Select STATUS/FAULT position.

T.O. 31R2-2URC-121

indicated in Receiver-Transmitter, Radio RT-1446/URC, T.O. 31R2-2URC-81, chapter 3, and the 1 KW Power Supply, as indicated in Power Supply PP-7913/URC, T.O. 35C1-2-892-1, chapter 3. Ensure that the associated 100 Watt Transceiver received a "PASSEd" on the BIT.

- b. Set POWER ENABLE/OFF switch to the ENABLE position; then turn on 1 KW LPA from the associated 100 Watt Transceiver front panel by using the [2ND][AMP PWR] keyboard controls. If the 1 KW LPA has never been turned on or if the power has been off for more than 10 seconds, there will be a three minute warm-up period upon power application before the 1 KW LPA can go to the OPERATE mode. When the power is applied, the STANDBY indicator should come on and flash during the 3-minute equipment warmup. At the end of warmup, the STANDBY indicator should show a steady indication.

3-4. STEP-BY-STEP SEQUENCE FOR MANUAL BUILT-IN TEST PROCEDURE.

- a. Set the AUTO/MANUAL BAND switch to the band corresponding to the frequency selected on the associated 100 Watt Transceiver (bands begin at 0000 and end at 9999; for example, 2.1999 would fall in the 1.8 to 2.2 band, but 2.2000 would fall in the 2.2 to 3.0 band). After one second the band switch should drive to the switch position selected.
- b. Rotate the METER switch on the LPA front panel to the STATUS/FAULT position.
- c. Press the SELF TEST button on the LPA front panel.
- d. Check that all LPA front panel LEDs come on and that all LCD segments on the meter display are on. NOTE: If the test is initiated while the LPA is in warmup (STANDBY LED was flashing before the SELF TEST button was pushed), only fault codes 2-01 through 2-08 can be displayed. This is because the full routine cannot be run until the LPA is warmed up (refer to the automatic diagnostic BIT test description in the Appendix at the end of Chapter 6).
 - (1) A "PASS" message on the METER display indicates that the BIT (Built-In-Test) has been passed.

- (2) A fault code (0001 through 0022) on the METER display indicates that a part of the test has failed. All further testing is stopped. Refer to Table 6-2 (in Chapter 6) for an explanation of the fault codes.
- (3) Moving the METER switch out of the STATUS/FAULT position removes the LPA from the test mode. The fault code may be cleared by commanding the LPA to OPERATE from the 100 Watt Transceiver (if the LPA is placed in AUTO) or by moving the METER selector switch to the STATUS/FAULT position and then out again.
 - (4) If all indications are normal, proceed to the next paragraph.

3-5. STEP-BY-STEP SEQUENCE FOR AUTOMATIC BUILT-IN TEST PROCEDURE.

- a. Set the AUTO/MANUAL BAND switch on the LPA to AUTO.
- b. Command the 1 KW LPA to perform the SELF TEST from the 100 Watt Transceiver front panel by pressing the following keyboard controls in sequence: [2ND][STB/OPR], [2ND][TX KEY], [2ND][TEST]. Then, to unkey Transmitter upon completion of test, press [2ND][TX KEY].
- c. Check that all LPA front panel LEDs come on and that all LCD segments on the meter display are on.
 - (1) A "PASSEd" message on the 100 Watt Transceiver's display indicates that the BIT (Built-In-Test) has been passed.
 - (2) A fault code (2-01 through 2-22) on the 100 Watt Transceiver's display indicates that a part of the test has failed. (The fault code will also appear on the LPA's LCD display if the METER selector switch is moved to the STATUS/FAULT position.) All further testing is stopped. Refer to Table 6-2 (in Chapter 6) for an explanation of the fault codes.
 - (3) The fault code may be cleared by commanding the LPA to OPERATE from the 100 Watt Transceiver or by moving the

LPA's METER selector switch out of the STATUS/FAULT position.

- (4) If all indications are normal, proceed to the next paragraph.

3-6. INITIAL CHECKOUT. In the initial checkout the 1 KW LPA is checked for readiness through the use of the front panel controls and indicators. The checkout procedure should be conducted immediately after performing the initial power application. This sequence does not cover each feature of the 1 KW LPA, only those necessary to prove normal performance. Refer to chapter 4, Operation, for complete operation information. Features related to the use of companion equipment are not discussed. This sequence assumes the initial power application procedure has been performed.

3-7. STEP-BY-STEP SEQUENCE FOR MANUAL TUNING PROCEDURE.

- a. Set the associated 100 Watt Transceiver to the desired frequency.
- b. Select the band corresponding to the associated transceiver frequency using the AUTO/MANUAL BAND switch.
- c. Set the ANTENNA switch to the center position (50 OHMS).
- d. Set the METER selector switch to the COIL POS position.
- e. Using the spring-loaded TUNE control, preposition the coil to the value indicated on the Manual Tune Chart, figure 3-1, for the frequency selected on the 100 Watt Transceiver. Move the TUNE control toward MIN L or MAX L until the the number on the LCD display matches the number on the chart.
- f. Set the METER switch to the FWD PWR (WATTS) position or to the RF Plate (volts) position.
- g. When the bandswitch is finished tuning the bandswitch wafer, set the MANUAL TUNE PWR switch to the ON position. When this is done, a

TUNE POWER REQUEST message is sent to the XCVR and the 1 KW LPA is keyed. If a fault is detected while this switch is active, the 1 KW LPA will drop back to STANDBY and the MANUAL TUNE PWR switch must be turned OFF before the fault can be cleared.

- h. Observing the METER display, use the TUNE switch to tune the servo coil to the maximum rf output or rf plate volts by switching to MIN L or MAX L.
- i. Turn off the MANUAL TUNE PWR switch.

NOTE

Turning off the TUNE PWR switch notifies the 100 Watt Transceiver that the LPA is tuned, whether it actually is or not. Therefore, before you turn this switch off, make sure that you have correctly tuned the LPA. Otherwise, there is the possibility of a severe mismatch between the LPA and the antenna system, resulting in low forward power or a forward power fault.

- j. Set the MANUAL LOCAL KEY switch to the ON position. The 1 KW LPA should go to the OPERATE condition and the OPERATE indicator should come on steady.

3-8. STEP-BY-STEP SEQUENCE FOR AUTOMATIC TUNING PROCEDURE.

- a. Set the LOCAL KEY switch to OFF, and set the AUTO/MANUAL BAND select switch to the AUTO position. This deactivates all of the manual tune switches. On the 100 Watt Transceiver front panel, using the [2ND], [STB/OPR] keypad controls puts the 1 KW LPA in OPERATE.
- b. Select a different frequency band at the companion 100 Watt Transceiver, and key the 100 Watt Transceiver. The 1 KW LPA should tune to the new frequency in 10 seconds or less. If not, there is a problem in the 1 KW LPA.
- c. This completes the initial checkout procedure. If any problems were encountered during this procedure, refer to chapter 6, Maintenance.

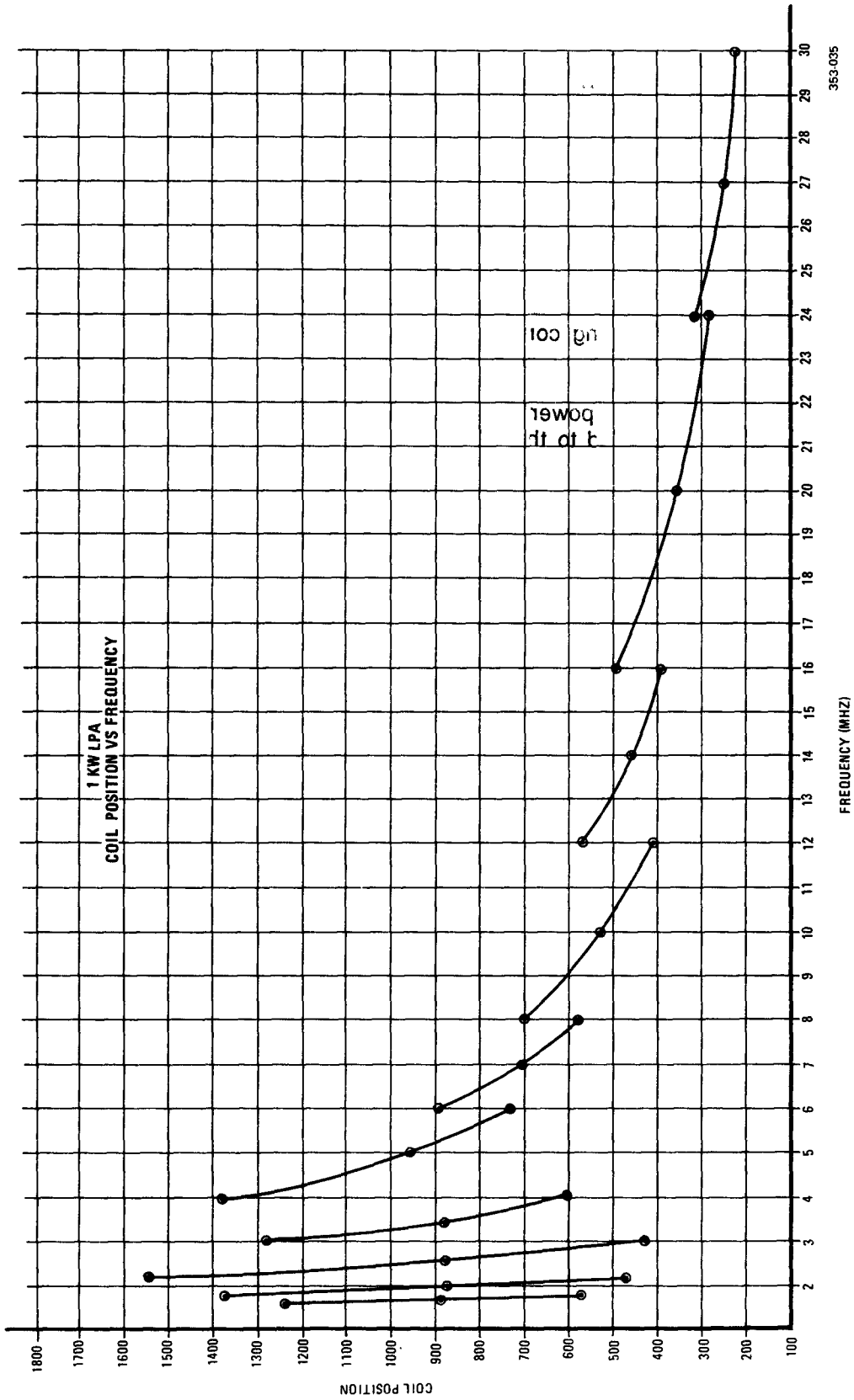

Figure 3-1. Manual Tune Chart

Section II. PREPARATION FOR RESHIPMENT

3-9. PREPARATION FOR RESHIPMENT.

This portion of the manual contains step-by-step procedures for disassembly and repacking the 1 KW LPA for reshipment.

3-10. STEP-BY-STEP DISASSEMBLY PROCEDURE.

- a. Ensure that all power sources associated with the 1 KW LPA and any interfacing companion equipment are shut down.
- b. Disconnect all interface cables, power cables, and grounding straps connected to the 1 KW LPA.
- c. Replace plastic dust caps on all LPA connectors.
- d. Carefully remove the 1 KW LPA from the stack mounted or rack mounted system configuration.

- e. Unbolt mounting brackets or slide brackets and slides, whichever the case may be, and pack them for shipment.

3-11. STEP-BY-STEP PACKING AND CRATING PROCEDURE.

- a. Refer to figure 2-1. Repackage the interface cables, the power cable, and the mounting hardware associated with the 1 KW LPA in the original or an equivalent container.
- b. Place the 1 KW LPA into the original or an equivalent container or packing box.
- c. Close and bind the container or packing box, using reinforced tape for reshipment.

CHAPTER 4
OPERATION

Section I. CONTROLS AND INDICATORS

4-1. CONTROL AND INDICATOR DESCRIPTIONS. All 1 KW Linear Power Amplifier (1 KW LPA) controls and indicators are explained in table 4-1 and shown in figure 4-1.

tuning, and status reporting. Most of the 1 KW LPA control functions are selected via two rotary switches. Toggle switches control the primary power application and MANUAL tuning mode.

4-2. FRONT PANEL CONTROLS. The three main functions associated with the 1 KW LPA controls and indicators are AUTOMATIC tuning, MANUAL

4-3. OPERATING CONTROLS. For specific information regarding the operating instructions of the 1 KW LPA, see section II of this chapter.

Table 4-1. 1 KW LPA, Operating Controls and Indicators

Controls or Indicators	Function
STANDBY (Indicator)	Indicates when the LPA is in STANDBY or WARMUP mode. Flashes for 3 minutes after power application (WARMUP mode) and is on steady during STANDBY mode.
OPERATE (Indicator)	Indicates when the LPA is in OPERATE mode. Light goes out if there is a fault and the LPA returns to STANDBY mode.
HV ON (Indicator)	Indicates when the high voltage (i.e., more than 100 volts) is applied to the power amplifier tube.
FAULT (Indicator)	Indicates when a FAULT exists in the LPA. Remains lit until the fault is cleared.
SELF TEST (Push button switch)	Used to activate the BIT self test routine.
METER (LCD Indicator)	Four digit LCD (Liquid Crystal Display) that displays the selected METER function; e.g., % of PRI PWR, 13.5 VDC, DC PLATE (VOLTS), I_k (mA), RF IN (WATTS), RF PLATE (VOLTS), FWD PWR (WATTS), REFL PWR (WATTS), ANT VSWR, COIL POS, or STATUS/FAULT.

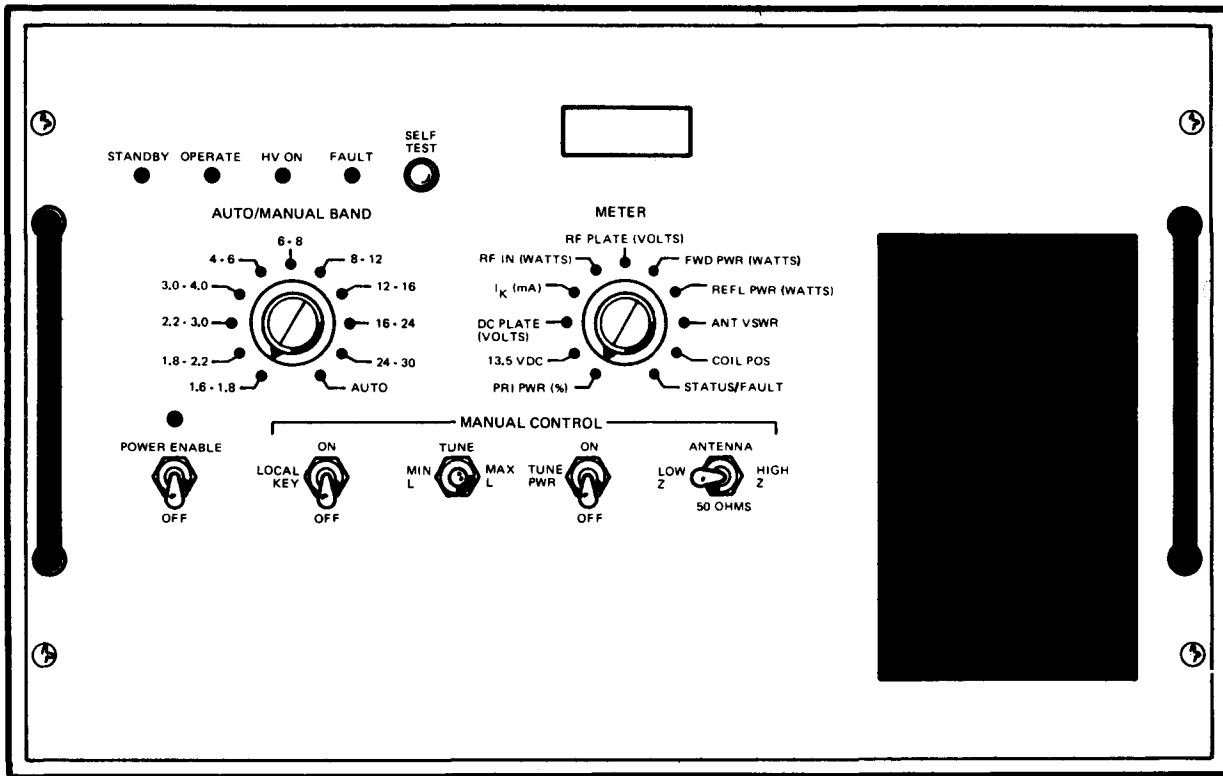

353-005

Figure 4-1. 1 KW LPA, Operating Controls and Indicators

Table 4-1. 1 KW LPA, Operating Controls and Indicators (Continued)

Controls or Indicators	Function
AUTO/MANUAL BAND (Control Wafer Switch)	Selects auto or manual self test routine operation in the chosen band. In Auto mode, tuning is initiated by a Tune command from the 100 Watt transceiver and is controlled by the microprocessor. In Auto mode, the MANUAL TUNE, MANUAL TUNE POWER, and MANUAL LOCAL KEY controls are inactive. When not in Auto mode, the switch controls the position of the band wafer. The 1 KW LPA has 10 bands.
METER (Control Wafer Switch)	Selects the input to the METER display (e.g., PRI PWR (%), 13.5 VDC, DC PLATE (VOLTS), I _K (MA), RF IN (WATTS), RF PLATE (VOLTS), FWD PWR (WATTS), REFL PWR (WATTS), ANT VSWR, COIL POS, or STATUS/FAULT).
POWER ENABLE (Control Toggle Switch)	Controls the primary power input.
MANUAL CONTROL-LOCAL KEY (Control Toggle Switch)	Active only in Manual mode. When in the ON position, sends a Local Key message to the transceiver and keys the 1 KW LPA.
MANUAL CONTROL-TUNE (Control Spring-Loaded Center Toggle Switch)	Active only in Manual mode. Used to control the position of the tune variable coil.
MANUAL CONTROL-TUNE PWR ON/OFF (Control Toggle Switch)	Active only in Manual mode. Used to request or inhibit tuning power from the 100 Watt Transceiver.
ANTENNA LOW Z/50 OHM/HIGH Z	Active only in Manual mode. Used to improve impedance matching to the antenna. This three-position switch selects LOW Z, 50 OHMS, or HIGH Z.

Section II. OPERATING INSTRUCTIONS

4-4. INTRODUCTION. Operating instructions include only those for the 1 KW LPA. Refer to the technical manuals for any companion equipment such as the 100 Watt Transceiver, 1 KW Power Supply, or AN/URA-38 () Antenna Coupler.

4-5. OPERATING SEQUENCES. A summary of the paragraphs containing the operating instructions is provided for reference.

4-6. POWER-UP

4-7. WARM-UP

4-8. BASIC FUNCTION OPERATION

- a. Auto/Manual Band Selection
- b. MANUAL TUNE PWR Switch
- c. MANUAL CONTROL-LOCAL KEY Switch
- d. MANUAL CONTROL-TUNE Switch
- e. ANTENNA Loading Selection
- f. SELF TEST Switch
- g. METER Function Selection

4-9. TRANSCEIVER CONTROLLED OPERATIONS

4-10. MICROPROCESSOR CONTROLLED OPERATIONS

- a. Meter Display Update
- b. Fault Check
- c. Built-In-Test (BIT)

4-6. POWER-UP. The POWER ENABLE/OFF switch on the front panel must be in the ON position for the 1 KW LPA to operate. Power is then turned on and off from the front panel of the 100 Watt Transceiver.

4-7. WARM-UP. When the 1 KW LPA is turned on for the first time or if the power has been off for more than 10 seconds, a three-minute warm-up period must elapse before the 1 KW LPA can be placed in the OPERATE mode. During this time the MANUAL controls, TUNE PWR, LOCAL KEY, and ANTENNA, are disabled. The STANDBY LED indicator flashes during the warm-up period. After three-minutes the STANDBY LED indicator stops flashing and stays lighted. If the BIT (Built-In-Test) is initiated during the warm-up period, some but not all functions are tested.

4-8. BASIC FUNCTION OPERATION. The functions selected from the 1 KW LPA front panel include: Auto/Manual Band selection, Manual Tune

Power, Manual Local Keying, Manual Tuning, Manual Antenna Loading, Self Test, and Meter Functions.

a. Auto/Manual Band Selection.

(1) The front panel, 11-position, AUTO/MANUAL BAND rotary switch selects between the automatic mode of operation and the manual mode of operation in the chosen frequency band. In AUTO mode, tuning is automatic and is controlled completely by signals from the associated 100 Watt Transceiver. In this mode, the Manual Tune, Manual Tune Power, Manual Local Key, Manual Antenna Loading, and Self Test controls are disabled.

(2) When AUTO/MANUAL BAND switch is not in the AUTO position, the 1 KW LPA is in MANUAL mode and the switch selects the current operating frequency band. The 1 KW LPA has 10 operating frequency bands. Selecting a new switch position causes the internal band switch wafer to be turned to its corresponding position. Before the wafer can turn, the microprocessor will wait until the operator leaves the band switch in one position for more than one second. Then the microprocessor sends an RF Mute signal to the associated 100 Watt Transceiver and unkeys the 1 KW LPA. The microprocessor will not turn the bandswitch wafer while there is RF power at the XCVR RF input of the 1 KW LPA. The Manual Tune Power and Manual Local Key controls are disabled while the wafer is turning.

b. MANUAL TUNE PWR Switch. When manual band is selected and the MANUAL TUNE PWR switch is moved to the ON position, a Tune Power Request message is sent to the associated 100 Watt Transceiver, and the 1 KW LPA is keyed. When the MANUAL TUNE PWR switch is activated, any previous fault indications are cleared. If a fault is detected while this switch is active, the 1 KW LPA will drop back to STANDBY and the MANUAL TUNE PWR switch must be turned off before the fault can be cleared. Activation of the tune mode causes the 100 Watt Transceiver to transmit a CW carrier emission. This level is then controlled by the 1 KW LPA to that which causes about 400 milliamperes of cathode current.

c. MANUAL LOCAL KEY Switch. When the MANUAL LOCAL KEY switch is set to the ON position, the 1 KW LPA is placed in OPERATE, and is

keyed. The MANUAL LOCAL KEY switch is active only in the MANUAL mode. When the MANUAL LOCAL KEY switch is activated, any previous fault indications will be cleared. If a fault is detected while this switch is active, the 1 KW LPA will drop back to STANDBY and the MANUAL LOCAL KEY switch must be turned off before the fault can be cleared. The MANUAL LOCAL KEY switch will key only the 1 KW LPA; the 100 Watt Transceiver must be keyed independently.

d. MANUAL TUNE Switch. The MANUAL TUNE switch allows the operator to fine tune the 1 KW LPA by controlling the position of the servo coil. Moving the switch to the left or to the right causes the coil to be moved toward MIN L or to MAX L by discrete steps. Holding the switch either to the left or to the right causes the coil to continue being moved by discrete steps, and causes the step size to be increased. The MANUAL TUNE switch is active only in the manual mode.

e. ANTENNA Loading Selection. The ANTENNA loading switch controls the output impedance to the antenna for the 1 KW LPA in the MANUAL mode. The 1 KW LPA microprocessor controls the output impedance to the antenna in the AUTOMATIC mode. The manual ANTENNA switch selects between LOW Z, 50 OHMS, and HIGH Z loading. When a new ANTENNA switch position is selected, in the manual mode, the 1 KW LPA microprocessor will not make the impedance change until after an RF MUTE request is sent to the 100 Watt Transceiver and the 1 KW LPA is unkeyed.

f. SELF TEST Button. With the AUTO/MANUAL BAND switch in any position except AUTO (the band selected should contain the frequency displayed on the 100 Watt Transceiver's front panel) and with the METER switch in the STATUS/FAULT position, pushing the SELF TEST Button initiates the BIT (Built-In-Test) procedure. The BIT procedure tests all functional modules and displays failures on the meter display when the STATUS/FAULT position of the METER switch is selected. At the start of the test, all front panel LCD segments and LED indicators are lighted. They remain lighted until the test is completed.

NOTE

If the test is initiated while the LPA is in

warmup (STANDBY LED was flashing before the SELF TEST button was pushed), only fault codes 2-01 through 2-08 can be displayed. This is because the full routine cannot be run until the LPA is warmed up (refer to the automatic diagnostic BIT test description in the Appendix at the end of Chapter 6).

(1) A "PASS" message on the METER display indicates that the BIT (Built-In-Test) has been passed.

(2) A fault code (0001 through 0022) on the METER display indicates that a part of the test has failed. All further testing is stopped. Refer to Table 6-2 (in Chapter 6) for an explanation of the fault codes.

(3) Moving the METER switch out of the STATUS/FAULT position removes the LPA from the test mode. The fault code may be cleared by commanding the LPA to OPERATE from the 100 Watt Transceiver (if the LPA is placed in AUTO) or by moving the METER selector switch to the STATUS/FAULT position and then out again.

g. METER Select Switch. The METER select switch controls the inputs to the METER LCD display. The eleven possible functions that can be displayed are shown in Table 6-1 in Chapter 6. Table 6-1 describes each function, indicates the range of measurement of each function, and indicates what the normal operating ranges are.

4-9. TRANSCEIVER CONTROLLED OPERATIONS. Automatic tuning of the 1 KW LPA is controlled completely by the companion 100 Watt Transceiver when the AUTO/MANUAL BAND select switch is in the AUTO position.

4-10. MICROPROCESSOR CONTROLLED OPERATIONS.

a. Meter Display Update.

(1) Periodically the microprocessor reads the appropriate inputs and calculates a new value for the METER LCD display. The Meter Display routine is inactive during the BIT routine. The analog inputs are read every 100 milliseconds and an average or peak value is displayed every second for the functions indicated in table 4-2.

Table 4-2. Meter Display Reading

Meter Function	Type of Reading
PRI PWR (%)	Average
13.5 VDC	Average
DC PLATE (VOLTS)	Average
I_k	Average
RF IN (WATTS)	Peak
RF PLATE (VOLTS)	Peak
FWD PWR (WATTS)	Peak
REFL PWR (WATTS)	Peak
ANT VSWR	Peak

(2) If COIL POS is selected, the coil position is displayed. Range is 100 to 1770.

(3) If the STATUS/FAULT position is selected and the FAULT LED is lit, a fault code is displayed. When the METER select switch is moved out of the STATUS/FAULT position, the fault code is cleared and the FAULT LED is turned off.

b. Fault Check. The 1 KW LPA performs periodic status checks on itself whenever it is energized. These checks are performed automatically and require no interaction or commands from the operator. These checks include the following and result in the indications or actions listed:

Check	Result
LPA temperature, I_k (cathode current)	If out of range for more than 2 seconds, the FAULT light comes on and the LPA goes into STANDBY (STANDBY light comes on)
Primary power, 13.5 V power supply, DC plate voltage, Forward power output, Reflected power output	If out of range for more than 3 seconds, the FAULT light comes on and the LPA goes into STANDBY (STANDBY light comes on)
The 1 KW LPA also performs operational status checks on itself. During tuning, keying, STANDBY/OPERATE status changes, it checks for expected reactions from the band switch, tuning coil, key relay, RF input sensor, forward and reflected power sensors, and the sensors for cathode current, DC plate voltage, and RF plate voltage. It also checks the serial control data link between the 100 Watt Transceiver and the 1 KW LPA.	If a fault is detected, the FAULT light comes on and the LPA goes into STANDBY (STANDBY light comes on)

NOTE

When the FAULT light comes on, the appropriate fault code will be displayed on the meter if the selector switch is moved to the STATUS/FAULT position. When the meter selector switch is moved out of the STATUS/FAULT position, the fault code will be cleared and the FAULT light will be turned off. The fault can also be cleared by commanding the 1 KW LPA back to OPERATE from the 100 Watt Transceiver's front panel or from the 1 KW

LPA's front panel (if in manual); but if the fault condition continues to exist, the FAULT light will come on again.

c. Built-In-Test (BIT). The BIT software for the 1 KW LPA tests all of its functions for the purpose of detecting hardware faults. For instructions on how to initiate the BIT test, see paragraphs 3-4 and 3-5; for a complete description of the events that occur during the BIT test, see the Appendix at the end of Chapter 6.

CHAPTER 5

THEORY OF OPERATION

5-1. INTRODUCTION. The 1 KW LPA is a microprocessor based amplifier designed for automatic operation with other HF transmitting and receiving system elements. In addition to the many automatic operating features, the amplifier also includes fault detection and isolation features and manual operating options as required to satisfy sophisticated user requirements.

a. Tuning. Tuning is either completely automatic, in response to serial data inputs from a compatible 100 Watt Transceiver; or manual, using the few simple front panel setup controls. Tuning times are minimal, limited only by the travel times for the servo-controlled tuning element. These circuits work with the microprocessor control system to minimize travel and response times.

b. Metering and Protection Circuits. Metering and protection circuits provide the operator and technician with visual feedback for all vital performance indicators. Similar inputs to the microprocessor continuously work to protect the unit and to provide optimum performance.

5-2. FUNCTIONAL ASSEMBLIES. Figures 5-1 and 5-2 are simplified functional diagrams of the 1 KW LPA that show all input and output functions. Figure 5-1 shows the RF signal path, and Figure 5-2 shows the support functions group. All major component assemblies are shown in a functionally related format. The microprocessor controls these functions to automate and optimize performance for a wide range of conditions. It is important that the technician understand these interrelationships so that the equipment can be most effectively used and maintained. The major subassemblies can be divided into four major subgroups as follows:

a. The RF signal processing subgroup, consisting of A1, A2, A3, and A10.

b. The power control subgroup, consisting of A3, A5, and A8.

c. The microprocessor control system, which includes the front panel, and consists of assemblies A6 and A7.

d. The support supply function, consisting of A4 and A9.

5-3. RF SIGNAL PROCESSING.

a. Refer to figure 5-1. RF drive from the 100 Watt Transceiver enters the 1 KW LPA at A3J3 on the rear panel and is routed by T/R relay A3K1 to the A1 tube assembly in the transmit mode. In the receive mode, A3K1 is deenergized and the J5 ANTENNA input is connected through the A10 LP Filter Assembly to A3J3 for receiver operation. T/R switching is controlled by the A6 PWB in response to an LPA Key Control input from either the 100 Watt Transceiver or the LPA front panel. The 100 Watt Transceiver RF input level is sampled and detected on the A3 assembly to develop metering and logic control outputs.

b. All amplification is accomplished by a single power triode operating in a grounded grid configuration. RF drive from the 100 Watt Transceiver is applied to the cathode circuit. Both cathode bias and cathode current for the power triode are controlled by the A5 Power Control PWB in response to both keyline and tune control signals. An RF plate voltage sample is sensed at the A1 Tube Assembly for use by the A6 Micro Control PWB Assembly for tuning and by the A5 Power Control PWB Assembly for protection against high plate voltage swings. Because of the power triode configuration, only one B+ voltage is required. The 3000 Vdc for this purpose is supplied by the Power Supply PP-7913/URC. The output of the A1 Tube Assembly goes directly to the A2 Tank Assembly.

c. The plate impedance of the power triode of the A1 Tube Assembly is transformed to the output antenna impedance, nominally 50 ohms, by the A2 Tank Assembly. The Tank Assembly contains seven component subassemblies as shown in figure 5-1. All functions are controlled by the A6 Micro Control PWB assembly in response to inputs from the A1 Tube Assembly and either the 100 Watt Transceiver or the front panel. Subassemblies A2A1 through A2A5 make lumped capacitance and inductance changes through a bandswitch controlled by an open-seeking

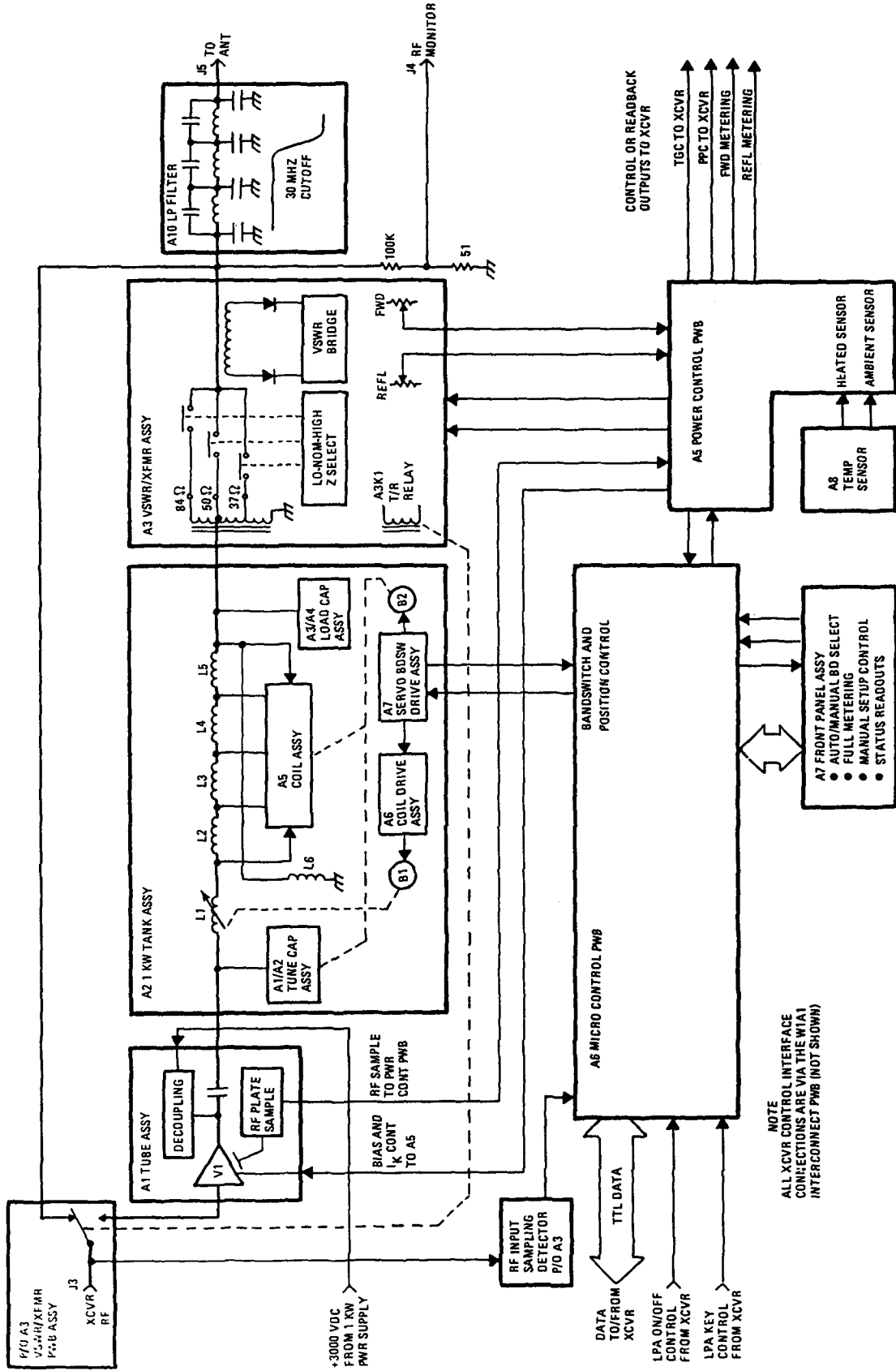

363-002

Figure 5-1. Functional Block Diagram

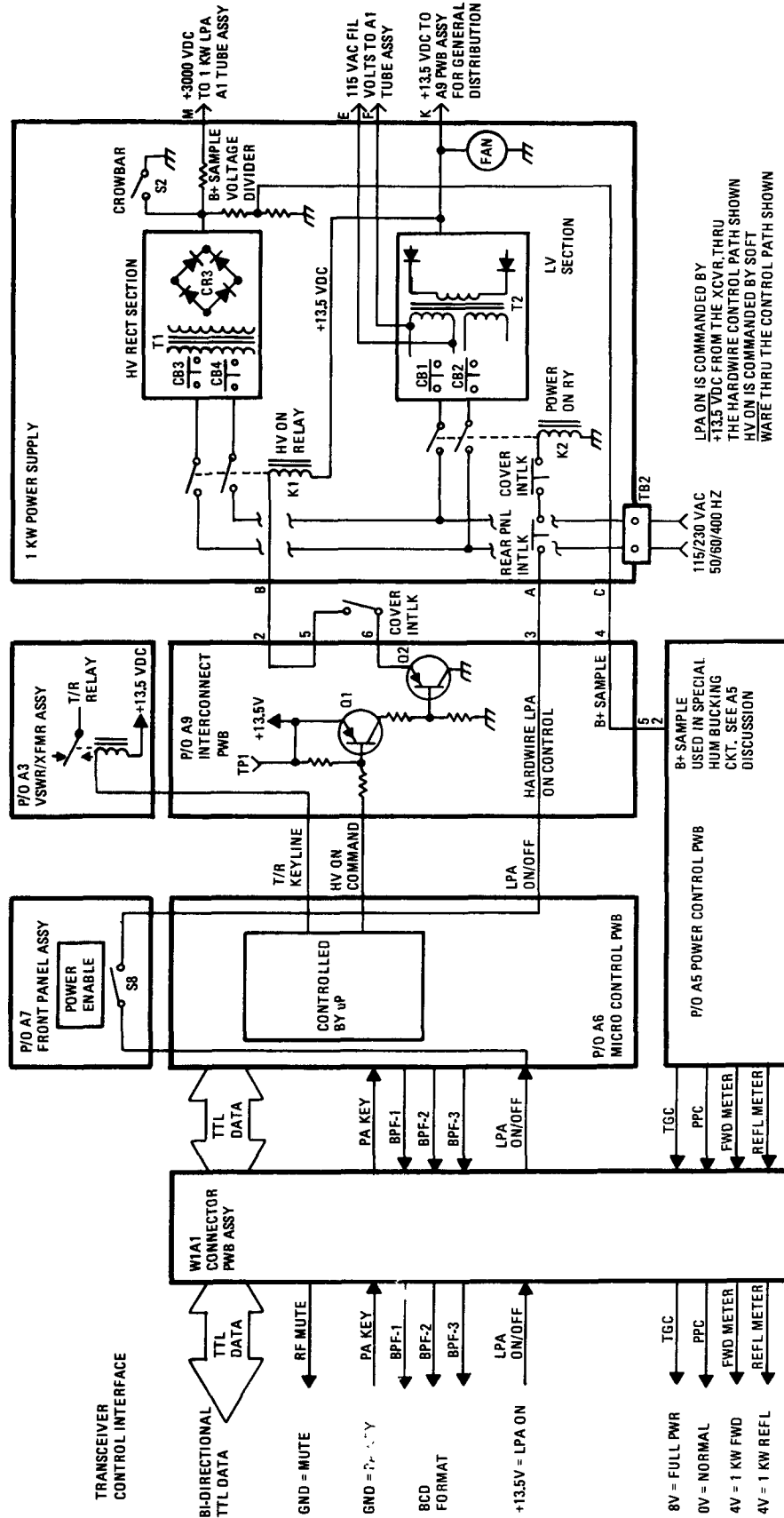

353-009

Figure 5-2. Support Function Block Diagram

T.O. 31R2-2URC-121

wafer, motor B2, and subassembly A2A7. Fine tuning is accomplished by variable inductor A2L1 driven by subassemblies A2A6 and A2A7.

d. The output from the A2 Tank Assembly is applied to the A3 VSWR/XFMR Assembly through impedance transformer T1, as shown in figure 5-1. The microprocessor automatically selects either the high, the nominal, or the low impedance transformation tap to optimize performance into various VSWRs. The VSWR Bridge, also part of the A3 Assembly, provides very precise analog outputs that are directly proportional to the forward and reflected power components on the output transmission line. These outputs are used for metering, power control (TGC and PPC), and in a number of software related control functions at A6. A separate 50 ohm RF Monitor is provided at J4. This provides a divided down sample of the rf output voltage that is usable with common test equipment.

e. RF output from the VSWR/XFMR Assembly is routed through the A10 Low Pass Filter Assembly to the J5 ANTENNA connector. The Low Pass Filter Assembly is designed to attenuate all signals, both harmonic and spurious, above 30 MHz, while not affecting those below 30 MHz. The nominal output impedance is 50 ohms.

f. Figure 5-2 shows the complete control interface between the transceiver and the 1 KW Power Supply. The power supply provides all operating voltages required at the 1 KW LPA other than the 115 Vac 400 Hz required for the B1 Fan Assembly. This voltage is generated at the A4 Fan Inverter, using +13.5 Vdc from the 1 KW Power Supply as the source. As shown in figure 5-2, all functions are controlled by the microprocessor, other than the LPA ON/OFF command, which is hardwired.

5-4. POWER CONTROL SUBGROUP. The power control subgroup consists of the A5 Power Control PWB Assembly, the Temperature Sensor PWB Assembly and the VSWR/XFMR Assembly. The Power Control Assembly uses the signals from the VSWR/XFMR Assembly to generate a TGC control signal that is representative of the envelope of the RF output signal. The TGC control signal is routed to the 100 Watt Transceiver for control of the system RF output level. The transceiver compares the TGC signal to an internal IF sample and adjusts its drive to maintain these two samples at equal amplitudes. Thus, if the IF sample is low, the power output of the 1 KW LPA will be correspondingly low. The advantage

of this type of control is that the system gain does not vary unnecessarily. As an example, should the operator stop talking, the system gain control loop does not increase in an attempt to artificially maintain a given output. Instead, the comparator type of TGC control system used maintains the same peak-to-valley ratio in the 1 KW LPA output as in the 100 Watt transceiver IF. The TGC signal in the 1 KW LPA is modified by the reflected power sample from the VSWR/XFMR Assembly and by the ambient temperature sample from the Temperature Sensor PWB Assembly as well as from other samples on the Power Control PWB Assembly, i.e. cathode current sample and RF plate to DC plate comparison sample, in order to maintain the 1 KW LPA within its safe operating parameters.

5-5. MICROPROCESSOR CONTROL. The microprocessor control system consists of the A6 Micro Control PWB Assembly and the A7 Front Panel Assembly. The Micro Control has a 64K memory and operates at a clock rate of approximately 5 MHz. It controls the automatic tuning and operating sequences for the 1 KW LPA. The Front Panel Assembly provides monitoring, metering, and manual controls as described in chapter 4.

5-6. SUPPORT FUNCTION GROUP. The W1A1 Connector PWB serves only as a wiring interface and contains no active components. The A9 Interconnect PWB serves a similar function; however, this PWB also includes the HV ON Relay Driver and logic level inverting transistor required to interface the Micro Control PWB A6 output with the HV ON Relay in the 1 KW Power Supply.

5-7. DETAILED DISCUSSIONS. The detailed discussions for each subassembly contain simplified functional diagrams, as appropriate. Refer also to the related schematic (circuit board schematics are contained in the depot manual) and the Interconnection Diagram FO-4, for circuit detail. The discussions are grouped functionally, in the same order used in the introductory paragraphs.

5-8. TUBE ASSEMBLY A1. Refer to the 1 KW Watt Tube Assembly schematic diagram in the Depot Manual, and also to figure 5-3, for this discussion. Figure 5-3 is a simplified diagram of the bias and I_k limit control circuits for the amplifier.

a. Cathode Circuits. The power triode, V1, is connected in a cathode driven, grounded grid

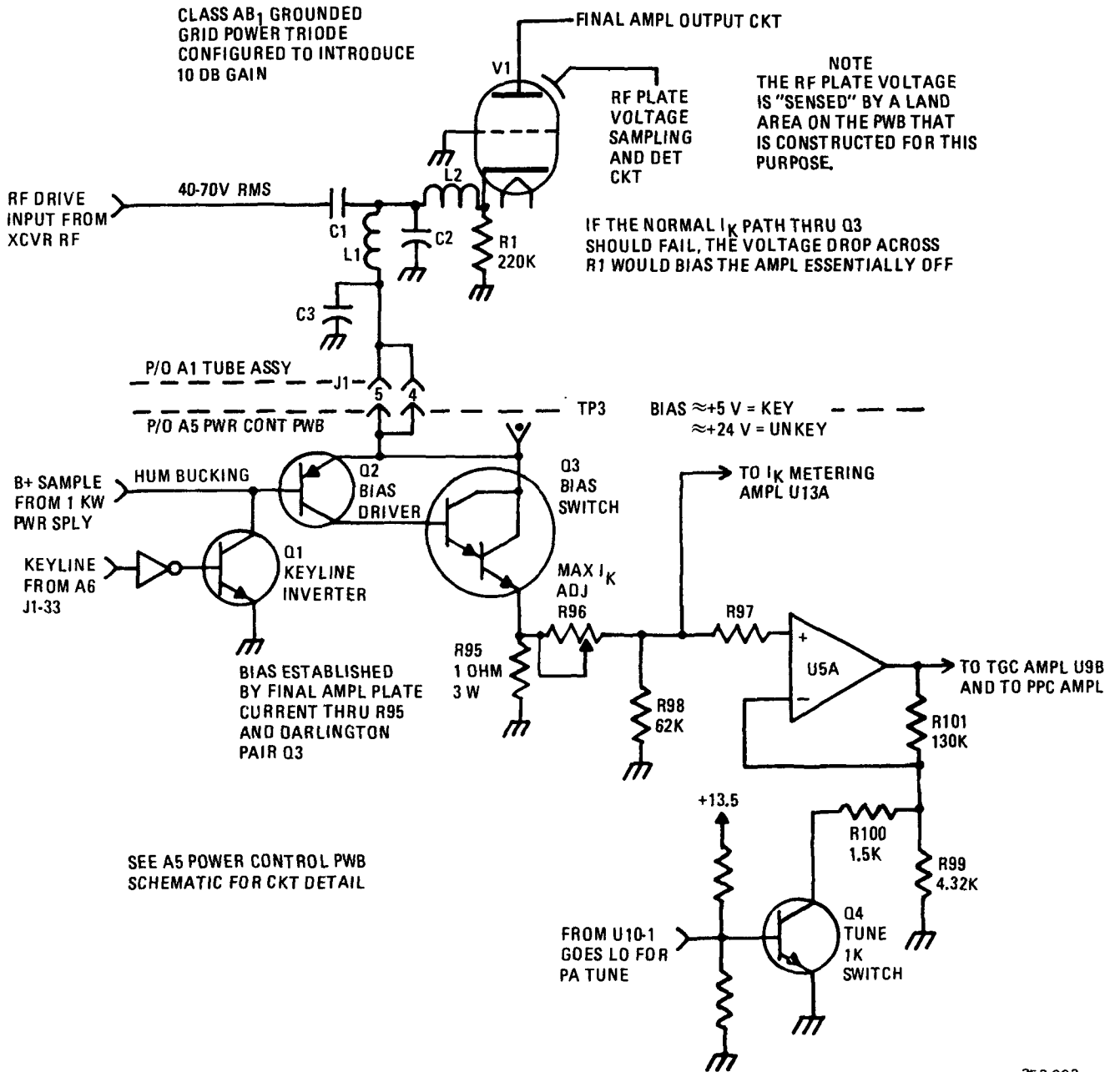

353-003

Figure 5-3. Bias and I_k Limit Control

T.O. 31R2-2URC-121

configuration. In this configuration, the tube is biased off with a positive voltage with respect to the grid, which is at ground potential. This voltage, approximately 20 volts, guarantees that the tube does not conduct when the transmitter is unkeyed. When the LPA is keyed, the tube is biased on, at approximately 10 volts, for class AB operation. Rf drive from the transceiver is applied to the cathode of the tube, causing the bias voltage to vary about the DC bias point. This variation causes the tube to conduct more when the bias voltage decreases and conduct less as the voltage increases. The rf voltage swing at the plate of the tube varies in phase with voltage variation at the cathode, causing amplification of the Rf drive present at the cathode of the tube.

With the transmitter keyed, the 100 Watt Transceiver output is connected through the T/R relay on the VSWR/XFMR PWB Assy to the RF input, A1J1-9, of the Tube PWB Assy. A1C1 is a DC blocking capacitor that prevents the cathode bias voltage from being fed back to the transceiver's output. Capacitor A1C2 and inductor A1L2 are a high frequency L-C matching network. The cathode bias voltage from the Power Control PWB Assy enters the Tube PWB Assy through connector A1J1-4/5 and is rf filtered by capacitor A1C3 and inductor A1L1. If the normal cathode bias circuit should fail open, resistor A1R1 at the cathode of V1 would develop a cutoff bias for V1. For a complete discussion of the bias circuit see paragraph 5-12-f for the Power Control PWB Assy. The cathode of the amplifier tube, V1, is indirectly heated by an isolated filament whose power, 5 Vac, is derived from the secondary of filament transformer T1. The primary voltage, 115 Vac, of T1 enters the tube Assembly through A1J1-12 and A1J1-14.

b. Plate Circuits. The DC plate voltage enters the Tube PWB Assy through a high voltage connector, P1, and is filtered by plate choke L1 and bypass capacitor C5. The rf output of tube, V1, passes through the output coupling/DC blocking capacitor C4 to the output connector. The DC plate voltage is sampled and divided down to a level usable by both the Power Control PWB Assy and the Micro Control PWB Assy by resistors R1 and A1R2. Zener diode A1VR2 provides protection and capacitor A1C4 acts as an rf bypass.

c. RF Plate Sample Circuit. The rf plate sample circuit provides an output that is proportional to the rf voltage present at the plate of the tube. This output is used by the Micro Control PWB Assy for tuning of the Tank Assy and is compared with a DC plate

voltage sample as part of the power control and protection circuitry on the Power Control PWB Assy.

The RF plate sample circuit is made up of a capacitor divider, a peak detector, and a resistor divider. The capacitor divider is formed by capacitors C2 and C3. Diode CR1, inductor L2, and capacitor C7 form the peak detector. Resistors A1R3, A1R4, and A1R5 divide the output of the peak detector to a level that is usable by the Micro Control PWB Assy. One volt of output at A1J1-3 represents 1000 volts of peak rf voltage swing at the plate of the tube. VR1 prevents the output at J1-3 from going above a level that is usable by the Micro Control PWB Assy.

5-9. TANK ASSEMBLY A2. Tank Assembly A2 includes all of the reactive tuning and loading components and their related control systems. Schematic coverage for this assembly is on two separate schematics (in the depot manual). The overall assembly schematic includes all detail except the Servo/Bandswitch Drive Assembly. A separate schematic details the Servo/Bandswitch Drive Assembly only.

a. RF Circuits. The Tank Assembly uses a pi network to transform the output impedance, nominally 50 ohms, to a higher impedance at the plate of the amplifier tube, nominally 1600 ohms. The pi network is composed of bandswitched tune capacitors, Tune Cap PWB Assemblies A1 and A2, variable inductor L1, fixed inductors on coil PWB Assembly A5, bandswitched load capacitors, and Load Cap PWB Assemblies A3 and A4. Both the Tune CAP PWB Assemblies and the Load Cap PWB Assemblies are made up of groups of fixed capacitors that are added together by a three-pole bandswitch. As an example, the tune capacitors for band 1 are capacitors A1C1, A1C2, A1C3, A1C4, A1C5, and A1C6, while the tune capacitors for band 2 are A1C3, A1C4, A1C5, A1C6, A1C7, and A1C8. Likewise, the Load Cap PWB Assy follows in a similar manner. The fixed inductors on the Coil PWB Assembly are switched in and out by bandswitch S1C (refer to figure 5-4). Bandswitch S1 (S1A, S1B, and S1C) is driven by motor B1 whose control is from the Servo/Bandswitch Drive PWB Assy and open seeking switch wafer S2. The variable coil L1 is the only tuning element in the Tank Assy, and its control is through the Coil Drive Assy and the Servo/Bandswitch Drive PWB Assy.

b. Bandswitch Drive Circuit. The Servo/Bandswitch Drive PWB Assy A2A7 is the control interface for all

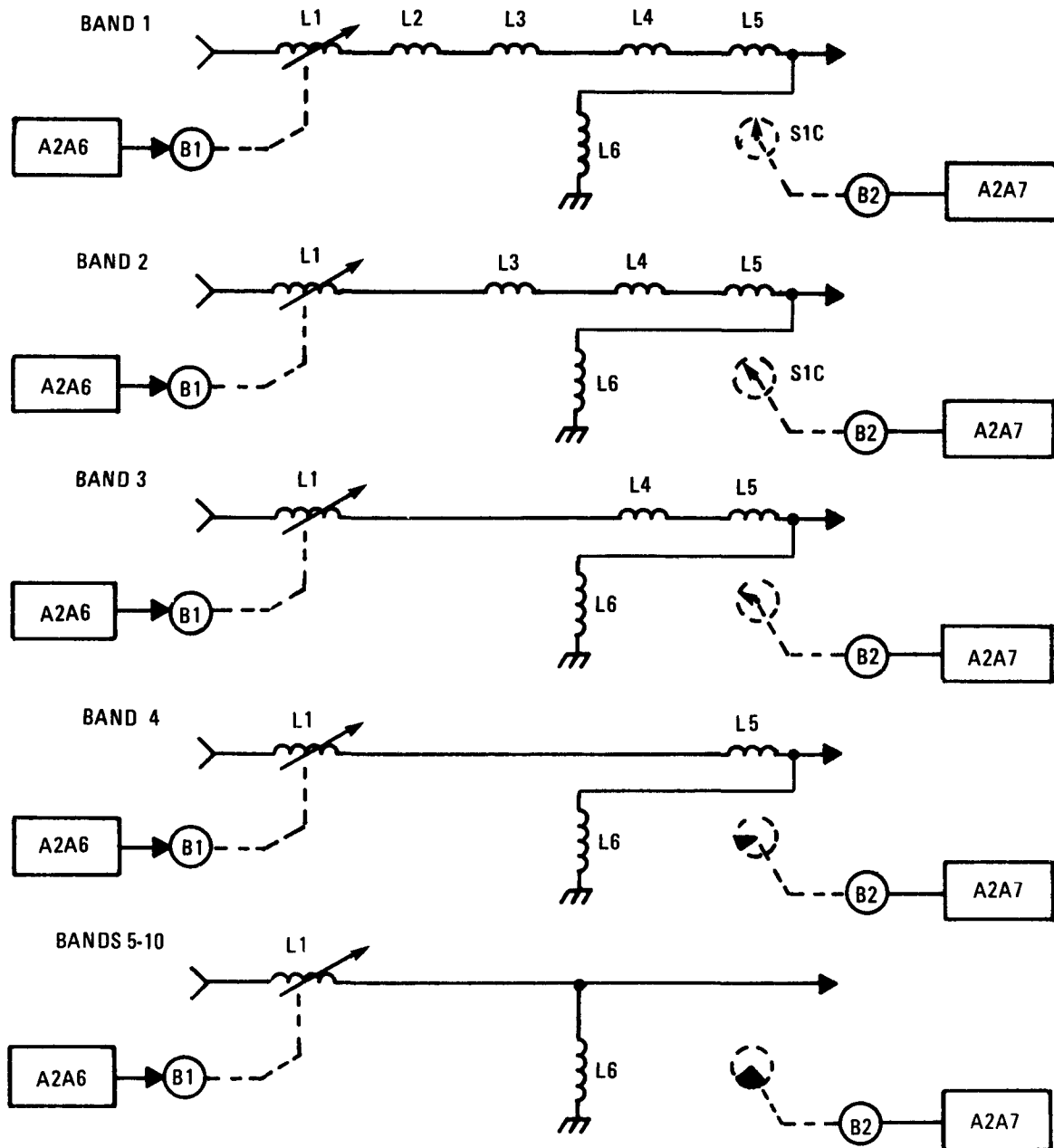

353-001

Figure 5-4. S1C Selected Output Inductor Sections

T.O. 31R2-2URC-121

units that make up the Tank Assembly A2. All control is from the Micro Control PWB Assy A6. Bandswitch control from A6 is a BCD code which is converted to a decimal code by BCD-to-decimal decoder A7U1. The output of U1 presents a high, 5 volts, on one of the ten output lines indicating the band that is selected. The ten outputs are connected to the bandswitch decoding wafer, S2, through steering diodes A7CR5 through A7CR14 and RF filters A7R43 through A7R46 and A7C16 through A7C25. The decoding wafer is open seeking; that is, when a new band is selected, the output of the decoder U1 for that band goes high. That output is connected through its steering diode and rf filter to switch S2, through S2 and its common, S2-C, back to the Servo/Bandswitch Drive PWB Assy. The high from S2-C turns on bandswitch drivers A7Q10 and A7Q11, energizing the bandswitch motor B1 through connector A7J3-1/2 and A7J3-3/4. The bandswitch motor runs until the decoding wafer's common opens at the band selected, removing the high from the bandswitch drive transistors and the drive to the motor. Resistors A7R21 and A7R22 divide the output motor voltage, 13.5 volts, down to 5 volts for a signal to the Micro Control PWB Assy to indicate that power is being supplied to the bandswitch motor. The Micro Control PWB Assy then generates an RF Mute signal to remove rf drive from the 100 Watt transceiver to prevent hot switching of the bandswitches.

c. Coil Drive Control Circuits. All in-band tuning is accomplished by the Coil Drive Assy A6 and Servo/Bandswitch Drive PWB Assy A7.

The Coil Drive Assy, A6, contains the coil drive motor, A6B1, and a limit switch, A6S1, which indicates when the variable coil is at either minimum or maximum inductance. Also, the A6 assembly has a shaft encoder, G1, that rotates turn for turn with the variable inductor. The outputs of the encoder, TWA and TWB, are pulses that are representative of the degree of rotation of the variable inductor. The two signals are shifted in phase such that the direction of rotation can be determined by sampling and comparing the two outputs.

The Servo/Bandswitch Drive PWB Assy, A7, contains the coil drive circuit. Since the circuit for driving the variable inductor toward minimum inductance is identical to that which drives the inductor toward maximum inductance, only one of the circuits will be discussed.

Control for driving the inductor toward minimum inductance enters the A7 assembly through J1-15. MIN L DRIVE, a low level signal, biases transistor Q4 on, which in turn biases both Q5 and Q6 on. With Q5 on, 13.5 volts is present at connector J2-5/6; and with Q6 on, ground is present at connector J2-7/8. This places 13.5 volts across the motor, such that it rotates the inductor toward minimum inductance. The MIN L DRIVE signal also biases Q7 on through resistor R13, which places 13.5 volts at the base of Q1. This inhibits Q1 from turning on, preventing the MAX L drive circuit from being active.

When no drive signal (either MIN L DRIVE OR MAX L DRIVE) from the Micro Control PWB Assembly is present at the A7 Assembly, the coil drive motor A6B1 is dynamically braked. Q9 is biased on through resistor R15. This biases both Q3 and Q6 on, which in turn places a ground at both J2-5/6 and J2-7/8 and across the motor. When either the MIN L DRIVE or MAX L DRIVE signal is present, Q9 is biased off through either CR2 or CR1, respectively, biasing both Q3 and Q6 off.

Limit switch information, either MIN L STOP or MAX L STOP, enters the A7 Assembly at J2-16 and J2-14. These signals are a high level, 13.5 volts. When the MIN L Stop is active, indicating that the variable inductor is at minimum inductance, transistor Q4 is biased off through CR16, thus inhibiting the MIN L drive circuit and shutting off the drive to the motor. Also, Q14 is biased on, applying a ground to J1-5, which indicates to the Micro Control PWB Assembly that the inductor is at minimum inductance. The Micro Control Assembly then removes the MIN L DRIVE signal.

The 5 volt regulator circuit supplies 5 volts for the encoder A6G1 and the BCD-to-decimal decoder A7U1. This circuit is made up of pass transistor Q12, zener diode VR1, and bias resistor R24. Resistor R23 drops part of the voltage, reducing the power dissipation in Q12; and capacitors C13 and C14 filter the output.

5-10. VSWR/XFMR PWB ASSEMBLY A3. Refer to the VSWR/XFMR schematic diagram for the following discussion. This schematic is found in the Depot Manual.

The VSWR/XFMR PWB Assembly contains an RF IN sample, a T/R relay, a VSWR bridge, an rf sample of the output power, and a transformer circuit that is

used to aid in matching the output impedance of the Tank Assembly to the antenna load impedance.

The RF IN sample contains a capacitor divider of the RF input, a peak detector, and a resistor divider network. Capacitors C11 and C12 form the divider sampling the RF input from the 100 Watt Transceiver. Inductor L6, diode CR4, and capacitor C13 make up the peak detector. Resistors R12 and R13 divide the output of the peak detector to a level usable by the Micro Control PWB Assembly for sampling and display.

T/R relay K1 switches the RF input from the 100 Watt Transceiver from the antenna when in receive to the Tube Assembly when in transmit.

The VSWR bridge is designed to provide analog outputs for both the forward and the reflected power output components. Current transformers T2 and T3 and resistors R2 and R3 produce a voltage that is proportional to the current on the RF output line. Capacitors C1 and C2 provide a voltage divider on the RF output line. The above two voltages are vectorially added to produce two voltages. One voltage is proportional to the forward power and one is proportional to the reflected power. Resistors R4 and R5 and capacitor C4 provide an adjustment to balance the bridge into a purely 50 ohm resistive output impedance. Diode CR1 rectifies the reflected sample, while diode CR2 rectifies the forward sample. Resistor divider R6 and R7 provides a calibrated output for the reflected power sample. This sample is nominally adjusted for 7 volts output for 1000 watts reflected. Likewise, resistor divider R8 and R9 provides a calibrated output for the forward power, which is also set for 7 volts at 1000 watts forward output.

An rf monitor is picked off the rf output line between the VSWR bridge and the output connector P2. Resistors R10 and R11 comprise a voltage divider whose output is capable of being connected to standard test equipment.

The impedance transformer T1 is used to better match the antenna impedance to that of the Tank Assembly. The transformer has three taps, one that equates to an antenna impedance of 36 ohms, one at 50 ohms, and one at 81 ohms. The Micro Control PWB Assembly monitors the forward power sample and the rf plate voltage sample during the tune cycle. When the ratio of the rf plate voltage to the forward power is below a specified value, the Micro Control

PWB Assembly activates the LOW Z input (an active low). When the ratio is within the specified window, the NOM Z input is activated. And when the ratio is higher than a specified value, the HIGH Z input is activated.

When the NOM Z input is selected, the active low biases on transistor Q2, which applies a positive 13.5 volts to the NOM Z relay K2. Relay K2 closes, connecting the output of the Tank Assembly directly to the antenna output connector P2.

When the LOW Z input is selected, the active low signal biases on Q1, which applies a positive 13.5 volts to the LOW Z relay K3. The rf output of the Tank Assembly is connected through transformer T1 and relay K3 to the antenna output connector P2. Transformer T1 and relay K3 to the antenna output connector P2. Transformer T1 has a 7:6 turns ratio, which equates to an impedance transformation of 49:36 ohms, thus optimizing the tank impedance for an antenna impedance of 36 ohms.

When the HIGH Z input is selected, transistor Q3 is biased on, activating HIGH Z relay K1. The rf output of the Tank Assembly is connected through transformer T1 with a 7:9 turns ratio. This equates to an impedance transformation of 50:81 ohms, thus optimizing the Tank Assembly's output impedance for matching to an antenna impedance of 81 ohms.

Only one of these inputs is active and then only when the LPA is in the transmitting mode. When in receive, all inputs are inactive, disconnecting the Tank Assembly from the antenna.

5-11. FAN INVERTER PWB ASSEMBLY A4. The schematic for the Fan Inverter Assembly is located in the Depot Manual. The assembly contains a fan inverter circuit that converts the 13.5 Vdc to 115 Vac at 400 Hz.

The fan inverter circuit contains both a driver transformer, T1, which sets the frequency of oscillation and an output transformer, T2, which sets the output voltage. The 13.5 volt output of the regulator circuit is applied to the center tap of the output transformer and to the center tap of the driver transformer through a filter network, capacitors C1 and C2 and inductor L1, and a bias network, C3, CR1, R1, R2, and R3, which supplies the return path for the driver transistors, Q1 and Q2. Resistor R4 provides an offset voltage across T1 such that transistor Q2 is

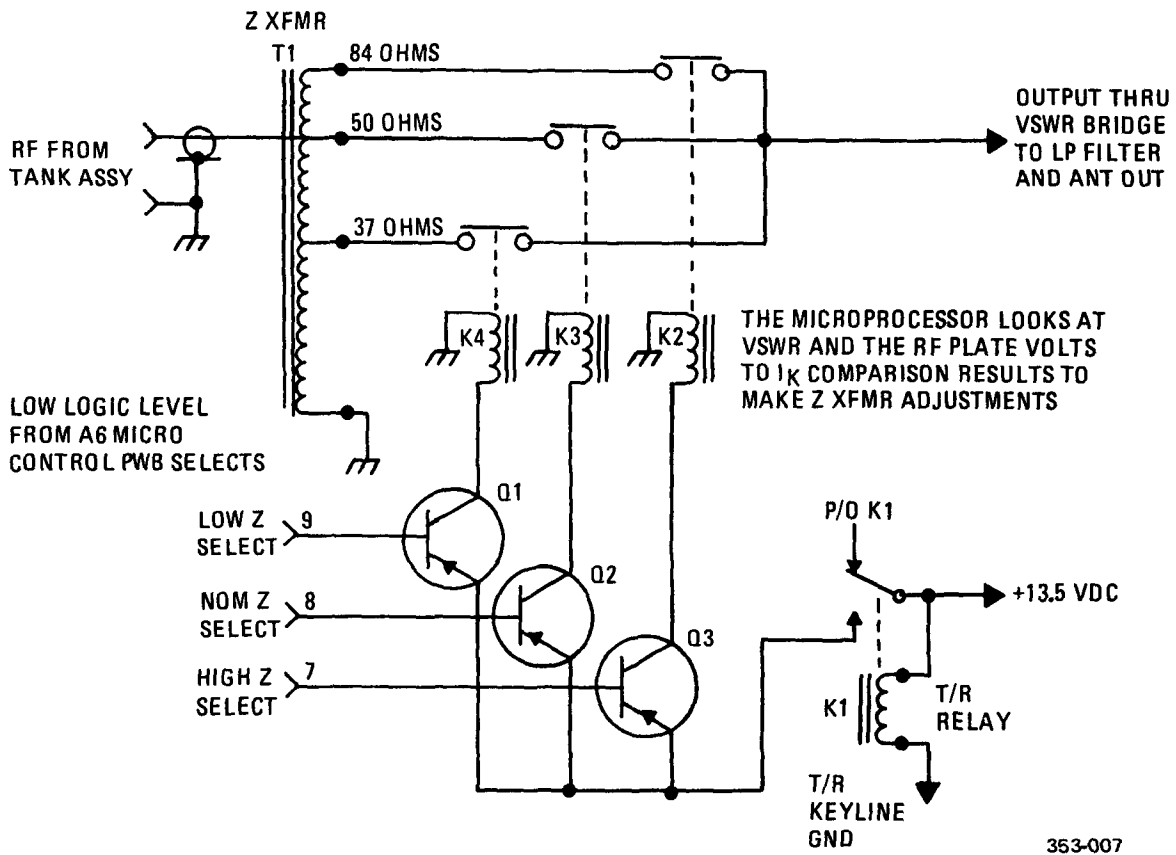

353-007

Figure 5-5. Z Transformation Simplified Diagram

biased on more than Q1 when power is first applied. This starts the inverter oscillating.

As Q2 conducts, a voltage is induced in winding T2-5/6 with a polarity that makes terminal 5 more positive than terminal 6. Then, by transformer action, terminal 1 is more positive than terminal 2. A voltage is also induced in driver transformer T1's primary that makes terminal T1-5 more positive than T1-1. By transformer action, secondary winding terminal T1-10 is more positive than terminal T1-8, causing Q2 to be more strongly forward biased. This action continues until Q2 is driven into saturation. When this occurs, the primary voltage can no longer increase and a condition of quasi-stable equilibrium is maintained. With a constant voltage across the windings, both the current and the magnetic flux increase until the core reaches saturation. At this time, the exciting current required by the transformer exceeds that which can be supplied by the Q2, causing Q2 to turn off. As the flux in the transformer collapses, the polarity in the transformer is opposite to that originally induced. Therefore, Q1 is biased on and is driven to saturation in a like manner. The flux will then again collapse, turning off Q1 and turning on Q2, thus completing the cycle. R-C networks R5/C4 and R6/C5 provide snubbing action to protect the transistors from any spikes that might be generated.

The AC voltage induced in the primary of T2 is coupled by transformer action to the secondary and to the output pins of J2. Capacitor C6 provides a phase shift for the fan.

5-12. POWER CONTROL PWB ASSEMBLY

A5. The Power Control PWB Assembly performs the following functions: meter processing, TGC and PPC generation, cathode biasing, and temperature sensor processing. Figure FO-2 is a simplified diagram of the Power Control PWB Assembly. The Power Control PWB Assembly schematic is located in the Depot Manual.

a. Meter Processing Circuits. The forward and reflected power samples from the VSWR/XFMR PWB Assembly A3 are directed to the Power Control PWB Assembly for processing for both metering information for the LPA front panel and for power control processing for generation of the TGC and PPC control signals.

The forward power sample enters the Power Control PWB Assembly at J2-8. Resistor network R5 and R9 sets the appropriate bias level for the forward power

sample from the output filter. Operational amplifier U1A has a gain of one and acts as a buffer to prohibit any interaction between the VSWR bridge on the VSWR/XFMR Assembly and the processing of the signal on the Power Control PWB Assembly. Diode CR1, resistors R15, and capacitor C5 peak detect the forward power sample, while divider network R17 and R19 sets the full power voltage to 4 volts at the input to FWD METERING AMP U2A. Amplifier U2A also has a gain of one and supplies the forward metering sample to the Micro Control PWB Assembly through J1-9 and to the 100 Watt Transceiver through J1-17. Zener diode VR4 inhibits the output from going above 5.1 volts.

The reflected power sample enters the Power Control PWB Assembly at J2-7. Resistor network R6 and R27 sets the appropriate bias level for the reflected power sample from the VSWR/XFMR PWB Assembly. Operational amplifier U1B has a gain of three and acts as a buffer to prohibit any interaction between the VSWR bridge on the VSWR/XFMR PWB Assembly and the processing of the signal on the Power Control PWB Assembly. Diode CR2, resistor R16, and capacitor C6 peak detect the reflected power sample, while divider network R18 and R20 sets the full power reflected voltage to 4 volts at the input to REFLD METERING AMP U2B. Amplifier U2B also has a gain of one and supplies the forward metering sample to the Micro Control PWB Assembly through J1-6 and to the 100 Watt Transceiver through J1-18. Zener diode VR5 inhibits the output from going above 5.1 volts.

b. TGC Circuits. The TGC signal is generated from a combination of the forward power and reflected power samples. FWD/REFLD AMP U3A uses the higher of the two signals to generate the TGC signal. The reflected power sample becomes equal to the forward power sample when the output VSWR is 2:1. At VSWRs above 2:1, the reflected power sample will be the dominant sample and thus control the level of the TGC voltage. The gain of U3A is adjustable from 1 to 1.25 and is set to amplify the input voltage to 8 volts as well as compensate for any variation of the IF sample in the 100 Watt Transceiver. The output of U3B is fed to the Control Loop Variable Gain Amp consisting of U9A and U8.

Unijunction transistor U8 acts as a voltage variable resistor which modifies the gain of amplifier U9A. As the voltage at U8-3 goes negative, the gain of U9A is increased, causing the envelope of the forward

T.O. 31R2-2URC-121

and/or reflected power sample to increase. This increase is detected by the 100 Watt Transceiver's TGC circuits as an rf power output signal increase, causing the rf power drive level to be reduced. There are four inputs that can cause a gain change if any of their thresholds are exceeded. The four inputs are the CW/FSK power threshold, the I_k cathode sample, the over temperature threshold, and the RF/DC plate sample.

The TGC output of amplifier U9A is connected through solid state switch U10 to output amplifier TGC Amp U9B. Switch U10 controls which signal is used as the TGC signal to the transceiver. When the LPA is in the tune mode, switch U10 is open, causing the power control of the LPA to be generated by the cathode current sample; and when in the ready mode, U10 is closed, enabling the control through the above path. LED DS1 indicates that there is TGC voltage being sent to the 100 Watt Transceiver, and diode CR26 prevents the TGC signal from going negative.

c. CW/FSK Power Control. This control is not normally used in the 1 KW LPA, but its operation if used is described below.

The forward/reflected power envelope is sampled through diode CR5 from the output of the FWD/REFLD Amp in the TGC control circuit by an averaging network consisting of diode CR6, capacitor C10, and resistors R32 and R33. Resistor R34 provides an adjustment of the output of this network to the input of the CW/FSK Avg Pwr Amp, U4A, which has a gain of two. The output of U4A is diode or-ed with the cathode sample, the ambient temperature sample, and the RF/DC plate sample to the Gain Control Threshold Amp U4B. When any of these samples exceed the threshold of 5 volts set by resistor divider R42 and R43, the output of U4B goes positive. The output of U4B is inverted by Gain Control Polarity Inverter U7A and fed to the controlling input of the unijunction transistor U8, thus increasing the gain of the Control Loop Gain Amp U9A and thereby causing the output power of the LPA to be decreased.

d. PPC Control Circuit. The PPC control circuit samples the outputs from the RF/DC plate comparator, the cathode current amplifier, and the FWD/REFLD Amp U3A. The cathode current sample and the forward/reflected power sample are divided by resistor network R107 and R108 and diode ORED to the output of the RF/DC plate comparator and

inputted to the PPC Unit Gain Amp U5B. Amplifier U5B has unity gain and acts as a buffer amplifier to supply a PPC voltage to the 100 Watt Transceiver where it is thresholded at 5 volts. When the output of the PPC amplifier exceeds this level, the transceiver's PPC circuits cause the transceiver's Rf output to drop to minimum output, thus causing an immediate power cutback out of the LPA. This circuit is used only as protection in the event that the TGC does not or cannot react to an overload to prevent damage to the LPA. The output of the PPC amplifier is also fed to the PPC Indicator Threshold Amp U13B. When the PPC output voltage exceeds 5 volts as set by resistor divider R116 and R117, the output of U13B goes high, lighting LED DS2, which indicates that the control loop is under PPC control.

e. RF/DC Plate Voltage Comparator. The peak rf voltage swing at the plate of the amplifier tube A1V1 is compared to the DC plate voltage. If the rf voltage swing approaches the maximum available swing as set by the DC plate voltage, a voltage is generated by the RF/DC Comparator and fed to both the TGC circuit and the PPC circuit for power cutback. This prevents the RF plate voltage swing from equalling the DC plate voltage and thus will prevent excessive grid current from being drawn by the amplifier tube.

The RF plate sample enters the Power Control PWB Assembly on connector J1-36 and is fed to the Micro Control PWB Assembly through J1-10 for monitoring and display. Likewise, the DC plate sample enters the Power Control PWB Assembly through J1-1 and is fed to the Micro Control PWB Assembly through J1-8. Zener diode VR7 and resistor network R83, R84, and R85 set both the threshold level and the gain of the RF/DC Comparator U3B. When the threshold is exceeded (this varies directly with the DC plate voltage), the output of U3B goes high and is fed to both the TGC through diode CR29 and the PPC circuit through CR18. The rate at which the rf plate voltage approaches the DC plate voltage will determine whether the TGC loop or the PPC loop will control the output power.

f. Cathode Current and Bias Circuits. The Power Control PWB Assembly contains both the cathode bias circuit and the cathode current control and metering circuits.

The cathode bias is set by the B+ sample voltage, resistors R93 and R94, and transistors Q1, Q2, and Q3. When Q1 is biased off, the amplifier tube is biased off at approximately 20 volts. This voltage is

set by a resistor divider network in the 1000 Watt Power Supply, resistors R93 and R94, and transistors Q2 and Q3. An active low KEYLINE signal present at J1-3 is inverted by Keyline Schmitt Trigger U11A to a high, which biases on Q1 and shorts out R94, lowering the voltage at the base of Q2 to about 5 volts, thus biasing on Q2, Q3, and A1V1. The B+ sample also contains an AC component that is representative of the AC ripple on the DC plate supply. This affects the bias point in such a way that the AC hum component on the RF output signal is cancelled or reduced.

Resistor R95 in the emitter lead of Q3 measures the cathode current. The resultant voltage is divided by resistors R96 and R98 and amplified by amplifier U5A. Resistor R96 is used to adjust the maximum plate current allowable before TGC/PPC cutback will take place. The gain of U5A is changed from approximately 31 during normal operation to approximately 120 during a tune cycle by the Tune I_K Switch being biased on by resistor R106 when Control Logic Switch U10 is open.

The LPA tunes on constant cathode current, and this is controlled by the output of U5A being fed to the input of the TGC Amp U9B through resistor R62 and diode CR16. During the TUNE mode, switch U10 is open, removing the forward/reflected power signal from the input to the TGC Amp and releasing the ground from diode CR15, allowing CR16 to conduct. During normal operation, switch U10 is closed, connecting the forward/reflected signal to the TGC Amp and grounding CR15, which reverse biases CR16 and biases off Tune I_K Switch Q4 through CR14.

The output of the cathode current amplifier is connected to the Gain Control Threshold Amp U4B through diode CR10, resistor divider R47 and R48, and diode CR8. If the output of the amplifier exceeds 7.4 volts, then the threshold of the Gain Control Threshold Amp causes the gain of the TGC loop to increase, thus reducing the RF power output. In addition, the output of the I_K amplifier U5A is connected to the PPC Amp U5B through CR19 to generate a PPC signal if the cathode current should exceed approximately 800 milliamperes.

g. Control Logic Switch. Control Logic Switch U10, in addition to switching the TGC input from the forward/reflected sample in normal to the cathode current sample in tune, also removes the internal power control potentiometer from the circuit in tune mode and antenna tune mode. Also, U10 switches the coupler tune power potentiometer into the TGC

circuit when the antenna tune mode is selected (an active low signal). Both the Power Control potentiometer and the Coupler Tune Power potentiometer feed voltages to the input of the TGC Gain Control Polarity Inverter, which increases/decreases the gain of the TGC loop, thereby reducing/increasing the RF output power of the LPA.

h. Temperature Sensor Circuits. The Power Control PWB Assembly contains the processing circuits for the Temperature Sensor PWB Assembly outputs. There are two outputs for the temperature sensor: an output that is proportional to the ambient temperature and one that is proportional to the air flow past the sensor assembly.

The ambient sensor input at J2-3 is directed to two comparators, one for air flow and one for overtemperature. The output of the sensor is 10 millivolts per degree Kelvin, which correlates to 2.73 volts for 0 degrees Centigrade. The Over Temp Threshold Amp U6B compares the output of the ambient sensor to the threshold voltage equating to 150 degrees C, above which its output goes positive. The output of the amplifier is directed to the variable gain stage of the TGC loop through diode CR11, resistors R49 and R47, and diode CR8, thus causing cutback of the output power when this threshold is exceeded. If the ambient temperature is not reduced through power cutback but increases, this increased level is detected by Fault Inverter U11E. The output of the inverter goes low, indicating a XMTR FAULT and causing the LPA to go in standby. Feedback resistor R152 sets up a hysteresis loop in the Over Temp Threshold Amp so that once cutback has occurred, the temperature must decrease beyond a certain point before the LPA can be brought back to full output power.

The ambient sensor output is also compared to the heated sensor input by Air Flow Comparator U6A. When the heated sensor is between 15 and 21 degrees above the ambient sensor, the output of the Air Flow Comparator goes positive, such that the Air Flow Fault Threshold Amp U7B is enabled. The positive output of U7B goes positive lighting LED DS4, LO AIR, and causing the output of Fault Inverter U11E to go low, indicating a XMTR FAULT.

i. -8 Volt Regulator. The -8 volt regulator consists of an oscillator, an amplifier, a rectifier, and a filter. Schmitt Trigger Oscillator U11C, resistor R129, and capacitor C51 form an oscillator whose frequency is

T.O. 31R2-2URC-121

approximately 12 KHz. Power Amp U12 amplifies the output of U11C to 13.5 volts. Capacitor C54 couples the output of U12 to rectifiers CR24 and CR25 and filter C55. The output voltage is approximately -8 volts.

5-13. MICRO CONTROL PWB ASSEMBLY

A6. The Micro Control PWB Assembly controls all functions within the LPA except for Power Enable, which is a hardwired signal from the 100 Watt Transceiver used to turn on the LPA, and TGC/PPC control signals that are hardwired and under control of the Power Control PWB Assembly. Refer to the Micro Control PWB schematic for the following discussion. This schematic is found in the Depot Manual.

a. Transceiver Data Link. Data between the 100 Watt Transceiver and the LPA is serialized and transmitted via a two wire link. Opto isolator U4 isolates the link from the receive data input of microprocessor U1. The TXD output of microprocessor U1 is normally high when in the receive mode. This output biases transistor Q2 on through hex buffer U10-4/5, which enables the opto isolator's input for reception of data from the 100 Watt Transceiver. The receive data from U4-1 is inverted by NAND gate U3-5/6/4 and inputted to the RXD input of the microprocessor. The transmit data is from the TXD output of the microprocessor and is transmitted to the 100 Watt Transceiver via hex buffer U10-4/5, transistor Q2, and opto isolator U4.

b. Clock Circuits. The clock control signals for the Micro Control PWB Assembly are generated by the clock oscillator circuit. This circuit consists of crystal oscillator Y1, capacitors C38 and C39, resistors R1 and R2, and hex inverters U8-1/2, U8-3/4, and U8-5/6. The output frequency of this circuit is 4.9152 MHz. This signal is connected to both the XTAL1 input of microprocessor U1 and a dual 4-bit counter, U31, from which all other clock frequencies are derived.

Three outputs of counter U31 are used. The 614.4 KHz clock is used for the clock for the analog to digital converter U6. The 307.2 KHz clock output is inputted to counter U32 where it is further divided down to a 150 Hz clock. This is connected to the second 4-bit counter of U31 where it is divided down to produce a 9.373 Hz clock. This clock is inverted by hex inverter U17-1/2 and ANDed with the power on reset circuit of resistor R20 and capacitor C13 by NAND gate U3-1/2/3. The output of U3 is connected to the reset line of microprocessor U1. This both

holds the microprocessor reset until the power supply stabilizes during power on and resets the micro if U31 is not reset within the clock frequency (approximately every .1 seconds) by the P3.4 output of U1 going low.

Counter U32, in addition to the 150 Hz clock, has three other clock outputs: a 153.6 KHz clock, a 300 Hz clock, and a 75 Hz clock. The first two are used by microprocessor U1, while the 75 Hz clock is used by the Front Panel PWB Assembly as the clock for the data display by the LCD.

c. Interrupts. The microprocessor has two interrupts: one is the 300 Hz clock, and the other is generated from the inputs of the Tank Assembly coil drive encoder, TWA and TWB. The TWA signal is shaped by schmitt trigger inverter U17-9/8 and fed to an edge detector circuit, capacitors C36 and C37, resistors R5-8 and R5-10, and hex inverter U17-5/6. This circuit detects both a positive going and a negative going pulse. Likewise, the TWB signal is shaped by U17-11/10 and fed to an edge detector circuit, capacitors C24 and C29, resistors R5-6 and R5-7, and hex inverter U17-3/4. These four outputs, TWA positive going, TWA negative going, TWB positive going, and TWB negative going, are ORed and inverted by NOR gate U26. The output of U26 is fed to the second interrupt of microprocessor U1. When any motion of the coil drive assembly is detected, the microprocessor is interrupted and records the motion of the variable inductor, thus keeping track of its position.

d. Input Latch. The input latch U28 converts eight parallel inputs to a BYTE word that is read into the microprocessor as required. Five of these inputs are from the Tank Assembly: BD SW ON indicates bandswitch motion, TWA and TWB indicate direction and rotation of the variable inductor, and MIM L LIMIT and MAX L LIMIT indicate when the variable inductor is at either end stop. The EXT INTLK input is not used. The XMTR FAULT is from the Power Control PWB Assembly and indicates a temperature fault. LPA KEY is a hardwired signal from the 100 Watt Transceiver, and when low activates the keylines in the LPA. The microprocessor polls the input latch as required by software by enabling the output enable input (OE) of U28.

e. Analog to Digital Converter. A/D Converter U6 converts any one of the eight inputs to a digital BYTE that is representative of the analog signal. All inputs are based on a 5 volt maximum value, while the output

is an 8 Bit word. Microprocessor U1 selects which input is to be converted through address inputs A0, A1, A2, and address enable input ALE of U6. The START input of U6 starts the conversion process, while the OE input enables the output lines so that the microprocessor can read the BYTE word.

f. Microprocessor Circuits. The microprocessor U1 is an 8 bit control oriented CPU. It contains a 128 byte read/write data memory, a full duplex UART, two 16 bit timer/counters, a programmable I/O, a 64 K byte bus expansion control, and oscillator and clock circuits. It can address up to 64 K bytes of external program memory and/or 64 bytes of external data.

The external program memory is contained in EPROM U2, while the data is held both in the on-chip memory as well as in the external RAM U29.

Input/output ports P0.0 through P0.7 serve as both address data outputs as well as data inputs. I/O ports P2.0 through P2.7 serve only as output address ports. Latch U12 latches the output address data, while the I/O ports are accepting data. Address decoder U27 decodes the address and the read and write commands for control of the external RAM U29, the Input Latch U28, the A/D Converter U6, and the Output Latch U13. Parallel to serial converter U15 converts up to eight parallel inputs to a serial eight bit word. The 1000 Watt LPA identification bit (KW ID) is the only input to U15.

I/O ports P1.0 through P1.7 are used for control and data to/from the Front Panel Assembly. Data is sent to and received from the Front Panel Assembly in serial form through the serial data line. Serial Clk is the clock signal for clocking in/out data to/from the shift registers on the Front Panel Assembly. LCD OUT ENABLE enables the LCD display, while F.P. IN ENABLE enables the front panel switch data to be sent to the microprocessor. F.P. OUT ENABLE enables the front panel LEDs.

g. Output Latches. Serial data from the microprocessor is clocked into 2 serial to parallel output latches U19 and U25 for control of the LPA. Output drivers U20 and U30 are open collector darlington transistor arrays that act as buffers between the output device and the serial to parallel latches. One output RF MUTE is sent to the 100 Watt Transceiver as a hardwired input for shutting off the RF drive from the transceiver during certain LPA operations.

Output Latch U13 is a parallel in/parallel out latch for latching parallel data from the microprocessor to the output. These outputs are also buffered by an open collector darlington transistor array and serve as control for the Tank Assembly.

There are a number of hardwired jumpers on the Micro Control PWB Assembly that program the method of control of the keylines. Both the T/R KEYLINE and the KEYLINE are programmed to be under microprocessor U1 control according to the inputs from either the 100 Watt Transceiver in AUTO mode or the front panel in MANUAL mode.

5-14. FRONT PANEL ASSEMBLY A7. The Front Panel Assembly contains both display and manual controls for operation of the LPA. Display is from both a group of LEDs and from an LCD whose input is controlled by a rotary switch. There are four toggle switches, one pushbutton switch, and two rotary switches.

a. LED Display. Information for four of the five LEDs is sent to the Front Panel Assembly via the serial data line from the Micro Control PWB Assembly. The serial data is clocked into the serial to parallel converter U26 by the F.P. OUT EN signal from the Micro Control PWB Assembly. The data is converted to parallel data by U26, and the parallel outputs of U26 drive their respective LED transistor drivers and LEDs.

The fifth LED, POWER ENABLE, is controlled by the 5 volt supply from the Micro Control PWB Assembly to indicate that power is present in the LPA.

b. LCD Display. The LCD display DS1 is a 4 digit, 8 segment display that is driven by LCD driver U28. The information for display is serially clocked into the driver chip U28 by the LCD CLK line and the LCD OUT EN line from the Micro Control PWB Assembly.

c. Manual Control Switches. Manual control switches, TUNE PWR, LOCAL KEY, TUNE, AND ANTENNA, as well as the SELF TEST pushbutton switch, are inputted to parallel in serial out chip U20. When the microprocessor activates the FP IN EN line along with the SERIAL CK, the data from the switches is sent to the microprocessor on the Micro Control PWB Assembly.

d. Rotary Switches. Data from the two rotary switches, METER and AUTO MANUAL BAND, is inputted to parallel in serial out chips U17, U18, and

T.O. 31R2-2URC-121

U19. These converters are controlled via the FP IN EN and SERIAL CK lines from the Micro Control PWB Assembly. It should be noted that the serial data from all front panel switches with the exception of the POWER ENABLE switch are linked together through parallel to serial converters U17, U18, U19, and U20.

5-15. TEMPERATURE SENSOR PWB ASSEMBLY A8. Refer to the Power Control PWB Assembly schematic for the following discussion. This schematic is found in the Depot Manual.

The Temperature Sensor PWB Assembly contains two temperature sensitive integrated circuits, U1 and U2. The output of the ICs varies directly with their temperature. For every degree Kelvin, the output increases 10 millivolts, such that at a room ambient of 20 degrees centigrade, the output would be 2.93 volts. Both outputs are fed to the Power Control PWB Assembly for processing.

a. Heated Sensor Circuit. The Heated Sensor U1 is preheated by resistor R1 to raise its temperature above the ambient temperature. If there is sufficient air flow past this sensor, it will be held at a lower temperature than if there was no air flow but still at a higher temperature than the ambient. This temperature is typically 7 degrees. Thus, the output of U1 will be representative of the air flowing past the sensor assembly.

b. Ambient Sensor Circuit. Ambient Sensor U2 measures the ambient temperature. It also contains an adjustment R2 to calibrate it with the U1 heated

sensor. Resistor R3 acts to equate the thermal mass of U1 to that of U2.

5-16. INTERCONNECT PWB ASSEMBLY A9. Refer to the Interconnect PWB Assembly schematic for the following discussion. This schematic is found in the Depot Manual.

The Interconnect PWB Assembly serves as a distribution board for the low voltage DC supply from the 1000 Watt Power Supply and also contains the H.V. ON driver and the primary power sample circuits.

Resistor divider R1 and R2 sample the low voltage power supply as an indication of the primary power input.

The active low H.V. ON signal from the Micro Control PWB Assembly that controls the high voltage contactor in the 1000 Watt Power Supply enters the Interconnect PWB Assembly on connector J1-2. This signal when low biases on transistor Q1, which in turn biases on Q2, providing a low signal on J3-2 if interlock switch S1 is closed. Diode CR2 clamps the contactor's coil when turned off.

5-17. LOW PASS FILTER ASSEMBLY A10. Refer to the VSWR/XFMR Schematic diagram for the following discussion. This schematic is found in the Depot Manual.

The Low Pass Filter Assembly is a three section filter designed to attenuate any signal, whether harmonic or spurious related, above 30 MHz. It is in both the transmit and the receive path.

CHAPTER 6

MAINTENANCE

WARNING

Voltages dangerous to life exist in this radio equipment. Before removing the top cover, disconnect the primary power and wait 30 seconds. This allows time for all voltages to bleed off.

Section I. INTRODUCTION

6-1. CHAPTER ORGANIZATION. This chapter is divided into five sections. Section I tells how the chapter is organized, describes the on-equipment maintenance philosophy, and introduces you to the concept of BIT (Built-In Test). Section II is a detailed presentation of how to use BIT to troubleshoot and repair the 1 KW Linear Power Amplifier (hereafter referred to as the LPA). Section III consists of removal and replacement procedures for the faulty modules identified by BIT. Section IV is dedicated to Periodic Maintenance Procedures. Section V contains alignment procedures for the replaceable modules.

6-2. ON-EQUIPMENT MAINTENANCE PHILOSOPHY. The 1 KW LPA is designed so that you can make most repairs without removing the equipment from its location. The procedures in this chapter should enable you to identify and correct most equipment malfunctions within 15 minutes.

NOTE

Field and organizational maintenance of the modules and circuit card assemblies is limited only to the removal, replacement, and alignments given in chapter 6.

Tool List

Screwdrivers:

- 3/16-inch flat blade (4 inches long)
- No. 1 Phillips
- No. 2 Phillips
- Phillips, right-angle, ratchet (optional)

Wrenches:

- 6-inch adjustable
- 0.050-inch Allen

Nut Drivers: 3/16, 9/16, 1/4, 5/16 (optional)

Needle Nose Pliers (optional)

Alignment Tool Kit

6-3. BIT (BUILT-IN TEST). The key to servicing the 1 KW LPA is a feature called BIT. BIT, which is an acronym for Built-In Test, consists of several systems, some manual and some automatic. These systems are the front panel controls and displays (including a multi-function meter), periodic automatic status checking, a manual diagnostic routine, and two different automatic diagnostic routines (an overall system test initiated from the 100 Watt Transceiver and an LPA self-test initiated from the 1 KW LPA). When used in conjunction with this manual, these systems allow rapid and accurate fault diagnosis.

MAINTENANCE

Section II. PERFORMANCE TESTING AND TROUBLE ANALYSIS USING BIT

6-4. FRONT PANEL CONTROLS AND DISPLAYS. The front panel controls and displays are utilized to control and monitor equipment operation during fault diagnosis. The displays provide an indication of equipment status, and a built-in meter allows digital monitoring of the parameters listed in Table 6-1. See Chapter 4 in this manual for a detailed discussion of all the controls and indicators.

6-5. PERIODIC AUTOMATIC STATUS CHECKING. The equipment performs periodic status checks on itself whenever it is energized. These checks are performed automatically and require no interaction or commands from the operator. These checks include the following and result in the indications or actions listed:

Check	Result
LPA temperature, I_K (cathode current)	If out of range for more than 2 seconds, the FAULT light comes on and the LPA goes into STANDBY (STANDBY light comes on)
Primary power, 13.5 V power supply, DC plate voltage, Forward power output, Reflected power output	If out of range for more than 3 seconds, the FAULT light comes on and the LPA goes into STANDBY (STANDBY light comes on)

Check	Result
The 1 KW LPA also performs operational status checks on itself. During tuning, keying, and STANDBY/OPERATE changes, it checks for expected reactions from the band switch, tuning coil, key relay, RF input sensor, forward and reflected power sensors, and the sensors for cathode current, DC plate voltage, and RF plate voltage. It also checks the serial control data link between the 100 Watt Transceiver and the 1 KW LPA.	If a fault is detected, the FAULT light comes on and the LPA goes into STANDBY (STANDBY light comes on)

NOTE

When the FAULT light comes on, the appropriate fault code will be displayed on the meter if the selector switch is moved to the STATUS/FAULT position. When the meter selector switch is moved out of the STATUS/FAULT position, the fault code will be cleared and the FAULT light will be turned off. The fault can also be cleared by commanding the 1 KW LPA back to OPERATE from the 100 Watt Transceiver's front panel or from the 1 KW LPA's front panel (if in manual); but if the fault condition continues to exist, the FAULT light will come on again.

6-6. MANUAL DIAGNOSTIC BIT ROUTINE.

A manual diagnostic BIT routine is included in this section to assist in fault diagnosis. Figure 6-1, which is a flowchart of the major steps in this routine, provides a sequence of observations which can be used to supplement the automatic BIT routines described in the following paragraph. In addition to Figure 6-1, which is the main flowchart, there are four supplementary flowcharts. Two of these (Flowcharts A and B) are referenced from Figure 6-1. The other two (Flowcharts C and D) are used for troubleshooting high and low output power conditions, respectively. For convenience, all flowcharts (Figures 6-1 through 6-16) are located at the end of this section.

6-7. AUTOMATIC DIAGNOSTIC BIT ROUTINES.

The automatic diagnostic BIT routines available for troubleshooting the 1 KW LPA are of two kinds. The first is an overall system test, which checks not only the LPA, but also the 100 Watt Transceiver and the Remote Control Unit. You initiate this routine from the transceiver front panel by pressing 2ND, TX KEY; 2ND, TEST; and 2ND, TX KEY. The second automatic BIT routine is a self-test for the 1 KW LPA only, which you initiate from the LPA (refer to the detailed procedure for running the LPA self-test in paragraph 6-8, d). In the first routine, fault codes are displayed on the transceiver's display (and also on the LPA's front panel meter when the selector switch is in the STATUS/FAULT position); in the second routine, fault codes are displayed on the LPA's front-panel meter (the meter selector switch must be in the STATUS/FAULT position). Upon detection of a fault, the test process stops and the corresponding fault code is displayed. The Appendix at the end of this chapter lists the events that occur during the LPA self-test (this same sequence of events occurs during the LPA portion of the overall system test, with minor variations). Successful completion of these routines assures you that the LPA is operationally ready for use. Running the automatic diagnostic BIT routines for performance testing and verification is therefore another major use of the BIT feature.

6-8. TROUBLESHOOTING WITH BIT.

The first stage in the troubleshooting process is becoming aware that a fault condition exists. This usually happens as the result of an observation (for example, you notice that a FAULT light is on) or as the result of a deterioration in the equipment's performance (for example, the person you're communicating with informs you that your signal is very weak). You can also use the front panel meter on the LPA to see whether its key operating parameters are within the

normal range (see Table 6-1). In any case, it's always a good idea to make a note whenever you notice anything unusual. This will come in handy if you have to do any troubleshooting. The nature of the fault determines whether you should use the manual diagnostic BIT routine or one of the automatic diagnostic BIT routines.

a. Using the FAULT lights. Whenever a FAULT light comes on during normal operation of the equipment, the first thing you should do is press 2ND, TEST on the transceiver front panel. This causes a fault code to be displayed. You can then look up the fault code in Table 6-2, which tells you what to do to identify and correct the problem.

b. Using the Manual Diagnostic BIT Flowchart. The manual diagnostic BIT flowchart, Figure 6-1, should be used whenever you observe an obvious problem while operating the 1 KW LPA, but none of the FAULT lights comes on. It suggests preliminary observations and actions that you should perform before you initiate one of the automatic diagnostic BIT routines. Sometimes, when there is a problem with the display or when the microprocessor is inoperative, you cannot use the automatic diagnostic BIT routines at all. In these cases, you must rely entirely on the manual diagnostic BIT flowchart.

c. Using the Automatic Diagnostic BIT Routines. When you initiate one of the automatic diagnostic BIT routines, you must use Table 6-2 to interpret the results. This table lists in numerical order all the possible fault codes for the 1 KW LPA (codes 2-01 through 2-02). Fault codes for the 100 Watt Transceiver (codes 1A1A1-0 through 1A1A19-2) and the Remote Control Unit (code 4-01) are listed in Chapter 6 of the technical manuals for those components. Note that in some cases the fault code itself is sufficient to identify the faulty module. In other cases, you will be required to do some additional checking to isolate the problem (this is the reason why flowcharts are used for many of the fault codes). Table 6-2 and the flowcharts tell you what to do to fix the problem, which in most cases consists of simply replacing a module. Instructions for removing and replacing the modules can be found in Section III of this chapter, "Removal/Replacement Procedures."

d. Running the LPA Self-Test. Use the following procedure to run the LPA self-test:

- (1) Rotate the AUTO/MANUAL BAND switch on the LPA front panel to the band that

contains the frequency displayed on the transceiver (bands begin at 0000 and end at 9999; for example, 1.7999 would fall in the 1.6 to 1.8 band, but 1.8000 would fall in the 1.8 to 2.2 band).

2-08 can be displayed. This is because the full routine cannot be run until the LPA is warmed up (refer to the automatic diagnostic BIT test description in the Appendix at the end of this chapter).

- (2) Rotate the METER switch on the LPA front panel to the STATUS/FAULT position.
- (3) Press the SELF TEST button on the LPA front panel.
- (4) Check that all LPA front panel LEDs come on and that all LCD segments on the meter display are on. NOTE: if the test is initiated while the LPA is in warmup (STANDBY LED was flashing before the SELF TEST button was pushed), only fault codes 2-01 through

NOTES

The automatic BIT routine transmits full power into the antenna system at the selected frequency. The consequences of this transmission should be considered before exercising BIT into an antenna. An alternative is to replace the antenna with a dummy load. Another important consideration when using the automatic BIT routine is that this routine tests the LPA only at the frequency currently selected by the 100 Watt Transceiver.

Table 6-1. Meter Functions and Normal Operating Ranges

Position	Function	Range/Units	Normal (Stby/ Warmup)	Normal (Operate, Keyed in CW)
PRI PWR (%)	Displays the average primary power input as a percentage of the nominal value	0% to 166%	90 to 110	90 to 110
13.5 VDC	Displays the average output of the low voltage power supply	0 to +22 Vdc	11 to 16	11 to 16
DC PLATE (VOLTS)	Displays the average plate voltage of the power amplifier tube	0 to +5000 Vdc	0	2400 to 3200(1)
I _k	Displays the average cathode (plate) current of the power amplifier tube	0 to 2000 mA	0	700 to 1100(1)
RF IN (WATTS)	Displays the peak RF input power from the 100 Watt Transceiver	0 to 250 W	0 to 100(2)	15 to 100(1)

(1) With a power output of 1 KW, as indicated on the FWD PWR meter.

(2) With the transceiver keyed; otherwise, the reading will be 0 W.

Table 6-1. Meter Functions and Normal Operating Ranges (Continued)

Position	Function	Range/Units	Normal (Stby/Warmup)	Normal (Operate, Keyed in CW)
RF PLATE (VOLTS)	Displays the peak RF voltage at the plate of the power amplifier tube (with respect to the average DC voltage)	0 to 5000 Vdc	0	1800 to 2400 ⁽¹⁾
FWD PWR (WATTS)	Displays the peak forward power at the RF output	0 to 1500 W	0	900 to 1100
REFL PWR (WATTS)	Displays the peak reflected power at the RF output	0 to 1500 W	0	0 to 100, depending on load ⁽¹⁾
ANT VSWR	Displays the peak ratio of the mismatch between the 1 KW LPA and its load, be it antenna, antenna coupler, or dummy load	1:1 to 999:1	0	1:1 to 2:1 ⁽¹⁾
COIL POS	Displays the servo coil position	100 to 1770	See Figure 3-1	See Figure 3-1
STATUS/FAULT	Displays a fault code. If the FAULT light is lit and the meter is switched to the STATUS/FAULT position, a fault code will be displayed. When the selector switch is moved out of the STATUS/FAULT position, the fault code will be cleared and the FAULT light will be turned off.	Fault codes		

Table 6-2. Fault Code Chart

NOTES

This table lists only the fault codes for the LPA (codes 2-01 through 2-22). For an explanation of the fault codes for the 100 Watt Transceiver (codes 1A1A1-0 through 1A1A19-2) and the Remote Control Unit (code 4-01), refer to Chapter 6 of the technical manuals for those equipments.

Fault codes for the LPA are listed as they appear on the 100 Watt Transceiver's display. On the LPA's display, "2-" appears as "00." For example, code 2-09 on the transceiver's display would appear as "0009" on the LPA's display.

Code	Explanation	Procedure
<u>2-01</u>	MICRO-CONTROL FAULT.	Replace Micro Control PWB Assy.
<u>2-02</u>	Not used	
<u>2-03</u>	PRIMARY POWER FAULT.	Refer to flowchart 2-03.
<u>2-04</u>	13.5 V SUPPLY FAULT.	Refer to flowchart 2-04.
<u>2-05</u>	TRANSMITTER FAULT.	Refer to flowchart 2-05.
<u>2-06</u>	BAND SWITCH DRIVE FAULT.	Replace Tank Assy. If problem persists, replace Micro Control PWB Assy.
<u>2-07</u>	SERVO COIL DRIVE FAULT.	Replace Tank Assy. If problem persists, replace Micro Control PWB Assy.
<u>2-08</u>	HIGH VOLTAGE ON IN STANDBY.	Refer to flowchart 2-08.
<u>2-09</u>	HIGH VOLTAGE FAULT IN OPERATE.	Refer to flowchart 2-09.
<u>2-10</u>	PLATE CURRENT ON W/BIAS OFF.	Refer to flowchart 2-10.
<u>2-11</u>	PLATE CURRENT FAULT W/BIAS ON.	Refer to flowchart 2-11.
<u>2-12</u>	RF MUTE NOT WORKING.	Check interconnecting cable between transceiver and LPA. Replace if necessary. If problem persists, replace Micro Control PWB Assy. If problem still persists, replace LPA/Coupler Interface PWB Assy in 100 Watt Transceiver (see transceiver technical manual).

Table 6-2. Fault Code Chart (Continued)

Code	Explanation	Procedure
<u>2-13</u>	NO RF INPUT W/TUNE POWER (Code 2-20 is displayed during auto tune.)	Refer to flowchart 2-13.
<u>2-14</u>	PLATE CURRENT FAULT WHEN KEYED	Refer to flowchart 2-14.
<u>2-15</u>	NO TUNE PEAK W/RF INPUT POWER.	Refer to flowchart 2-15.
<u>2-16</u>	FORWARD POWER FAULT.	Refer to flowchart 2-16.
<u>2-17</u>	VSWR/REFLECTED POWER FAULT. (Meter indicates VSWR >2.25:1.)	Check coax connections to Low Pass Filter Assy. If problem persists, check output coax cable to antenna system. If problem still persists, check antenna system. If AN/URA-38() Antenna Coupler is installed, refer to troubleshooting procedure in Chapter 4 of its technical manual. If problem still persists, replace VSWR/XFMR PWB Assy.
<u>2-18</u>	POWER GAIN FAULT.	Replace Tube Assy. If problem persists, replace Tank Assy. If problem still persists, replace Low Pass Filter Assy, or the VSWR/XFMR Assy.
<u>2-19</u>	Not used.	
<u>2-20</u>	AUTO TUNE FAULT. (This is not an automatic BIT fault code. This code should appear only during normal operation and only if the LPA fails to tune correctly.)	Initiate the LPA self-test (see par. 6-8, d), and use this table to diagnose the problem.
<u>2-21</u>	LPA-TRANSCEIVER LINK FAULT.	Check interconnecting control cable between transceiver and LPA. Replace if necessary. If problem persists, replace LPA/Coupler Interface PWB Assy in transceiver (refer to transceiver technical manual). If problem still persists, replace Micro Control PWB Assy.
<u>2-22</u>	CATHODE CURRENT W/NO FWD PWR (This is not an automatic BIT fault code. This code should appear only during normal operation. The meter indicates cathode current (I_k), but no FWD PWR.)	Initiate the automatic diagnostic BIT routine (either from the transceiver or from the LPA -- see par. 6-7 and 6-8, d), and use this table to diagnose the problem.

MANUAL DIAGNOSTIC BIT ROUTINE FAULT ISOLATION CHART

NOTE
REFER TO TABLE OF CONTENTS
FOR REPLACEMENT PROCEDURE
PARAGRAPH REFERENCES

NOTE:
IF A FAULT LIGHT
COMES ON AT ANY
TIME DURING THIS
PROCEDURE, STOP
AND PRESS "2ND,"
"TEST" TO DISPLAY
THE FAULT CODE.
THEN REFER TO
TABLE 6-2 FOR
INSTRUCTIONS.

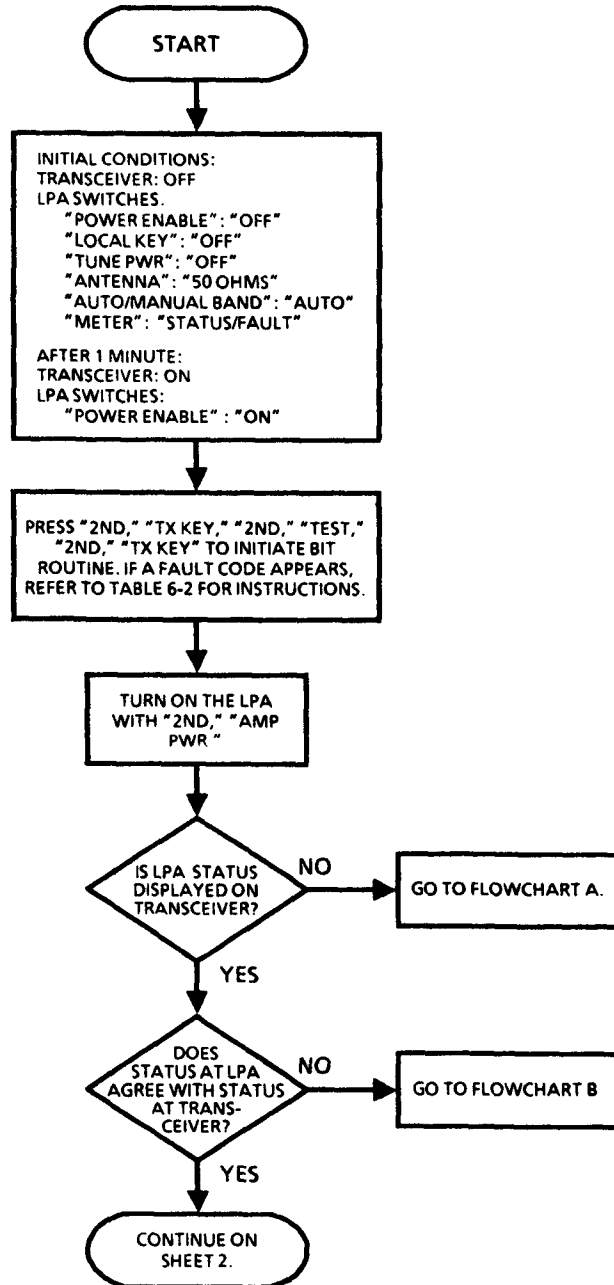

*353-016-1

Figure 6-1. Manual Diagnostic BIT Routine, Fault Isolation Chart (Sheet 1 of 3)

MANUAL DIAGNOSTIC BIT ROUTINE FAULT ISOLATION CHART (Cont.)

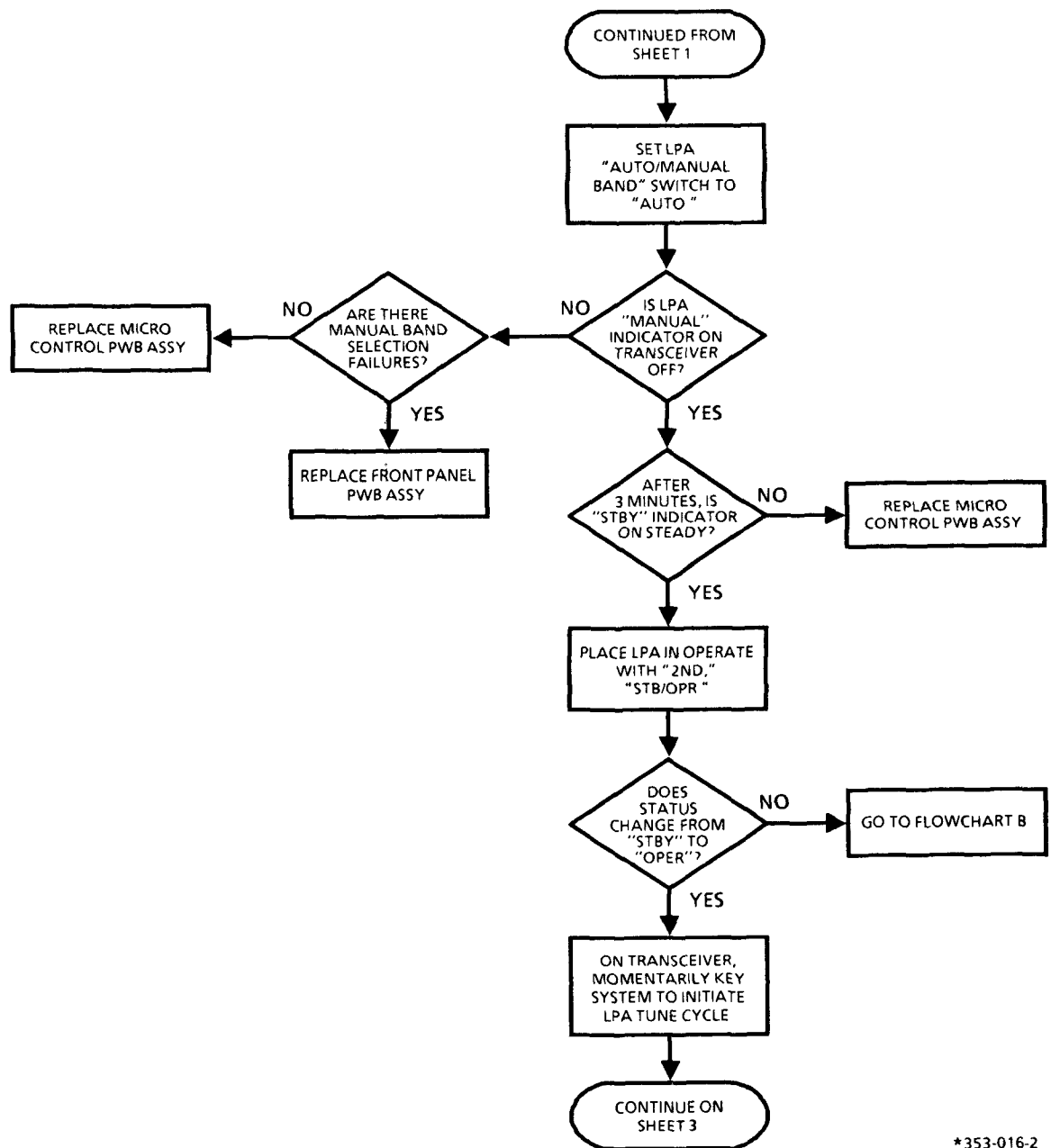

*353-016-2

Figure 6-1. Manual Diagnostic BIT Routine, Fault Isolation Chart (Sheet 2 of 3)

MANUAL DIAGNOSTIC BIT ROUTINE FAULT ISOLATION CHART (Cont.)

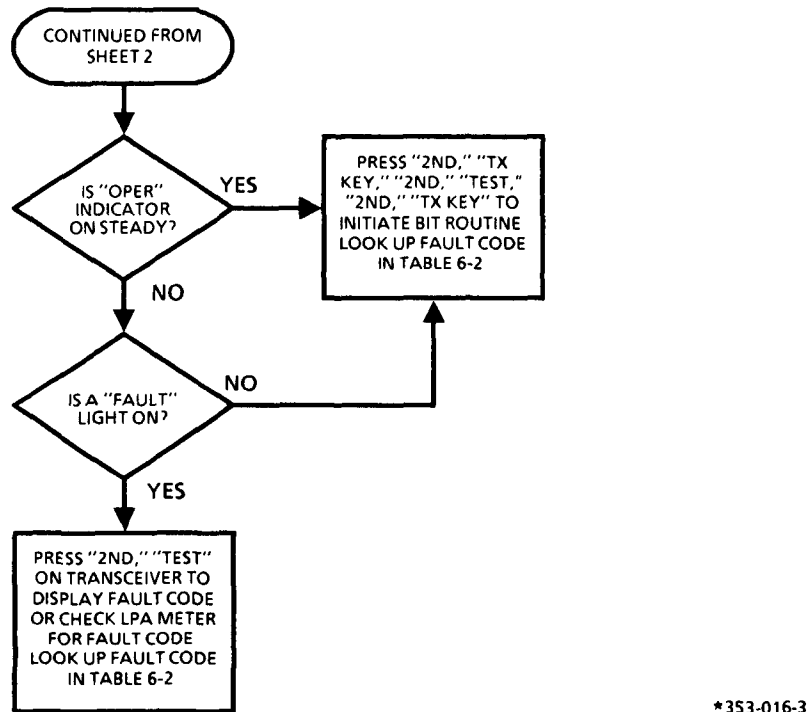
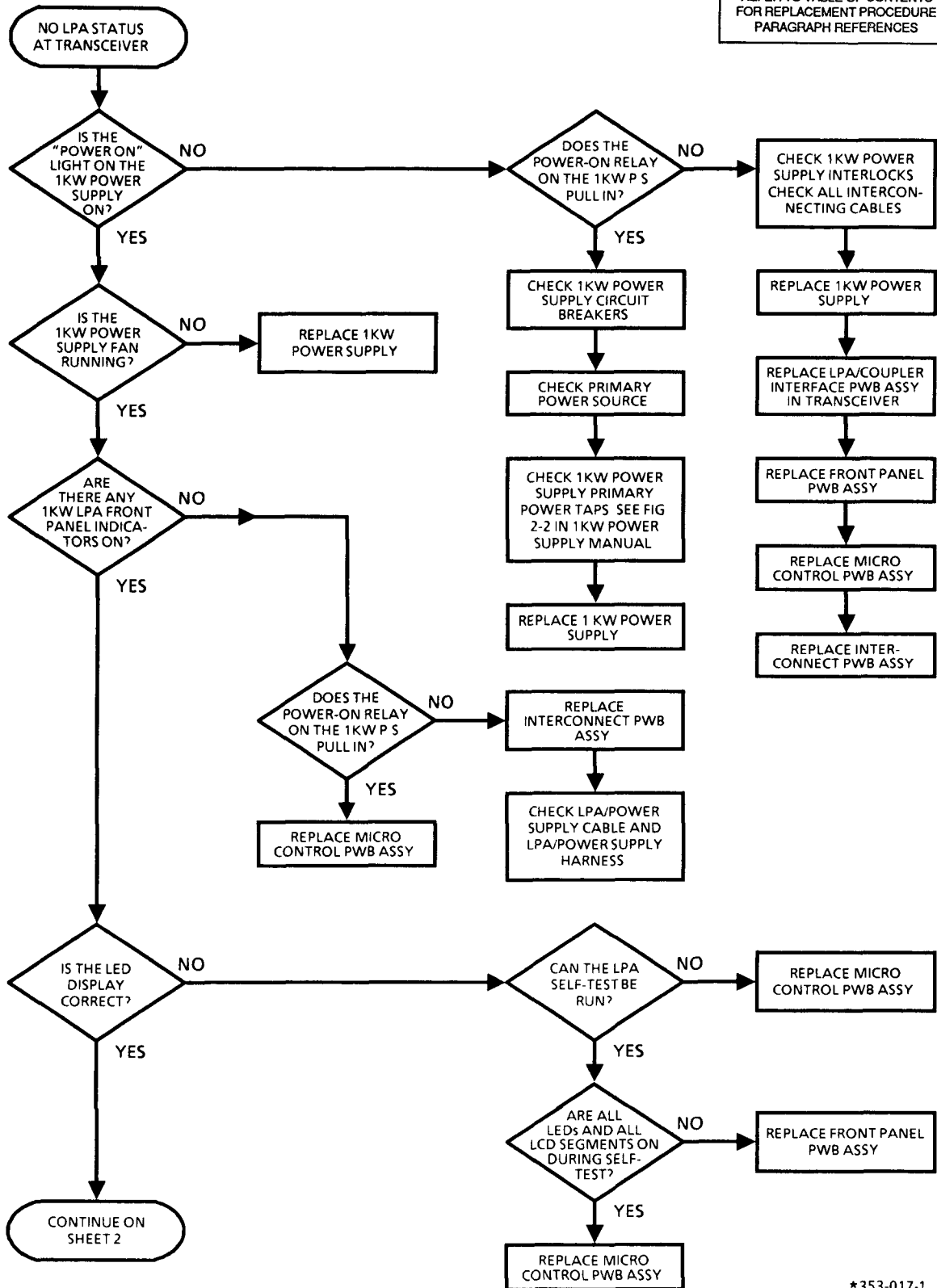

Figure 6-1. Manual Diagnostic BIT Routine, Fault Isolation Chart (Sheet 3 of 3)

FAULT ISOLATION CHART A

NOTE
REFER TO TABLE OF CONTENTS
FOR REPLACEMENT PROCEDURE
PARAGRAPH REFERENCES



*353-017-1

Figure 6-2. Fault Isolation Chart A (Sheet 1 of 2)

FAULT ISOLATION CHART A (Cont.)

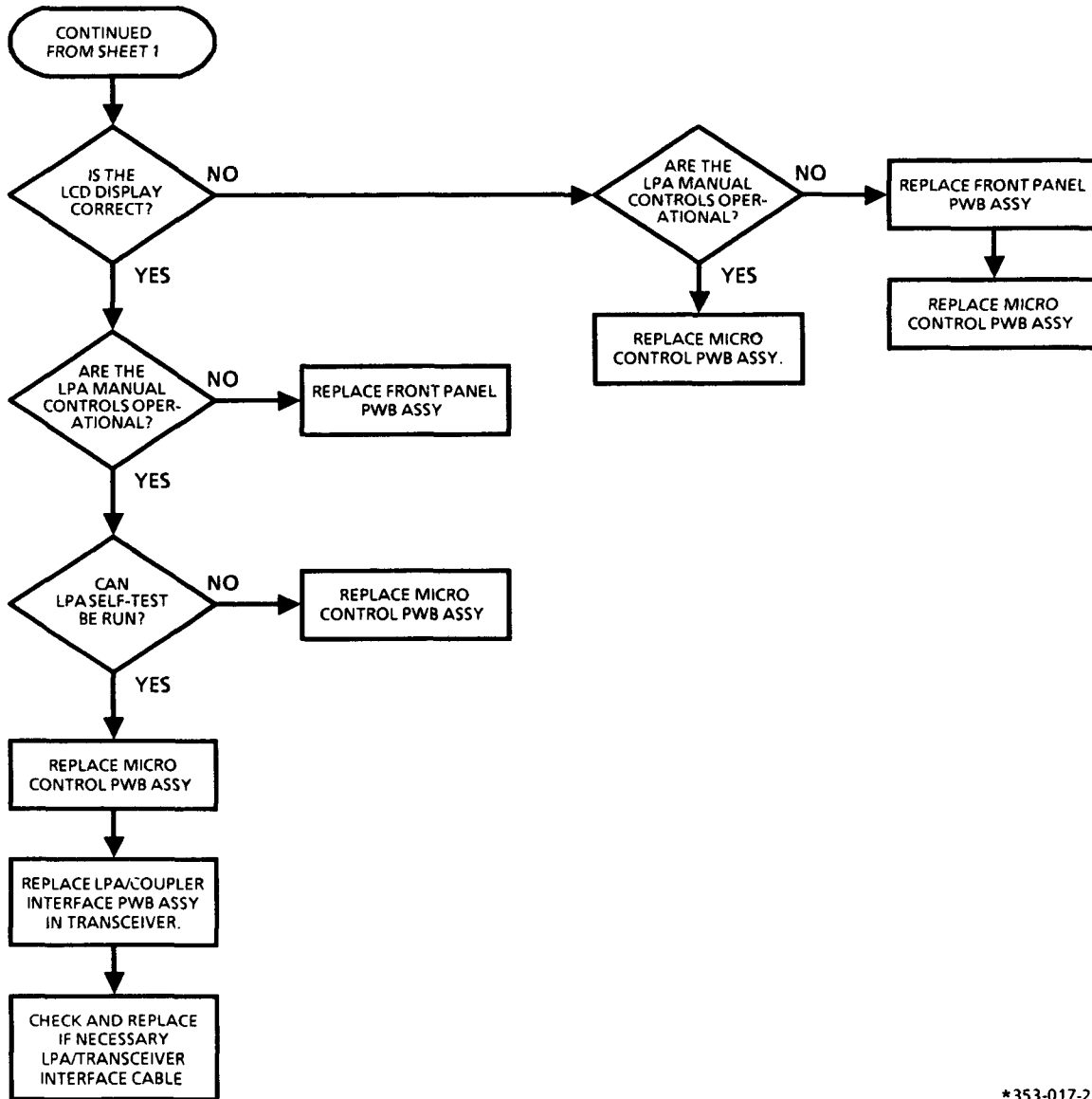

*353-017-2

Figure 6-2. Fault Isolation Chart A (Sheet 2 of 2)

FAULT ISOLATION CHART B

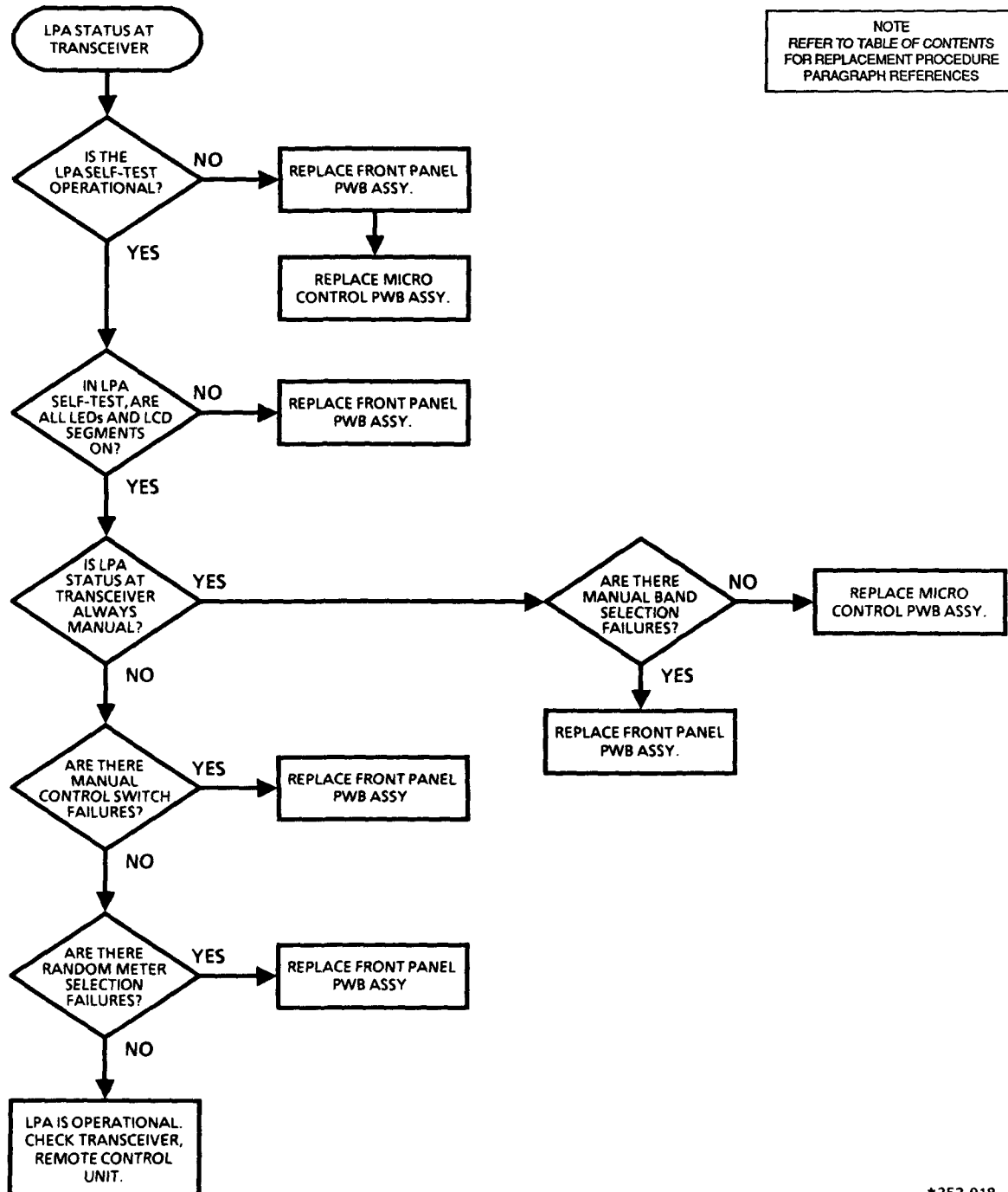

*353-018

Figure 6-3. Fault Isolation Chart B

FAULT ISOLATION CHART C

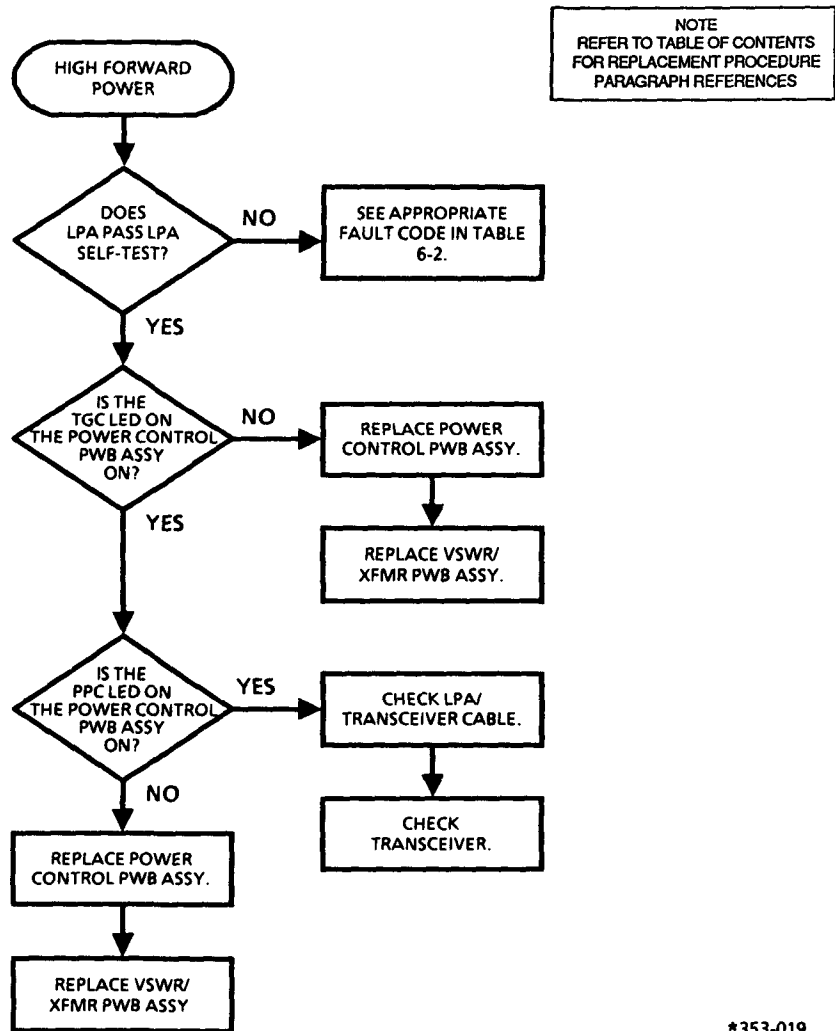

*353-019

Figure 6-4. Fault Isolation Chart C

FAULT ISOLATION CHART D

NOTE
REFER TO TABLE OF CONTENTS
FOR REPLACEMENT PROCEDURE
PARAGRAPH REFERENCES

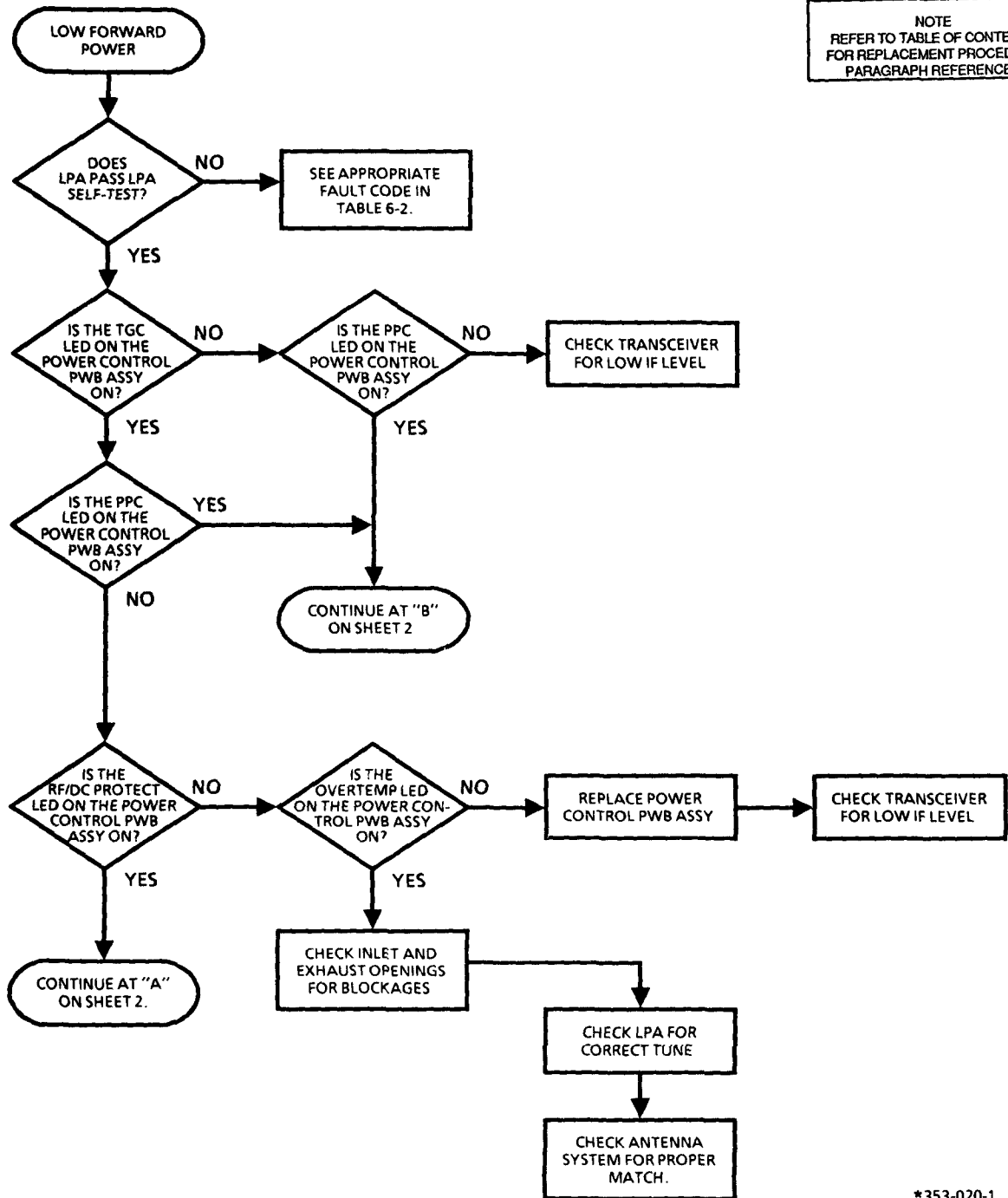

*353-020-1

Figure 6-5. Fault Isolation Chart D (Sheet 1 of 2)

FAULT ISOLATION CHART D (Cont.)

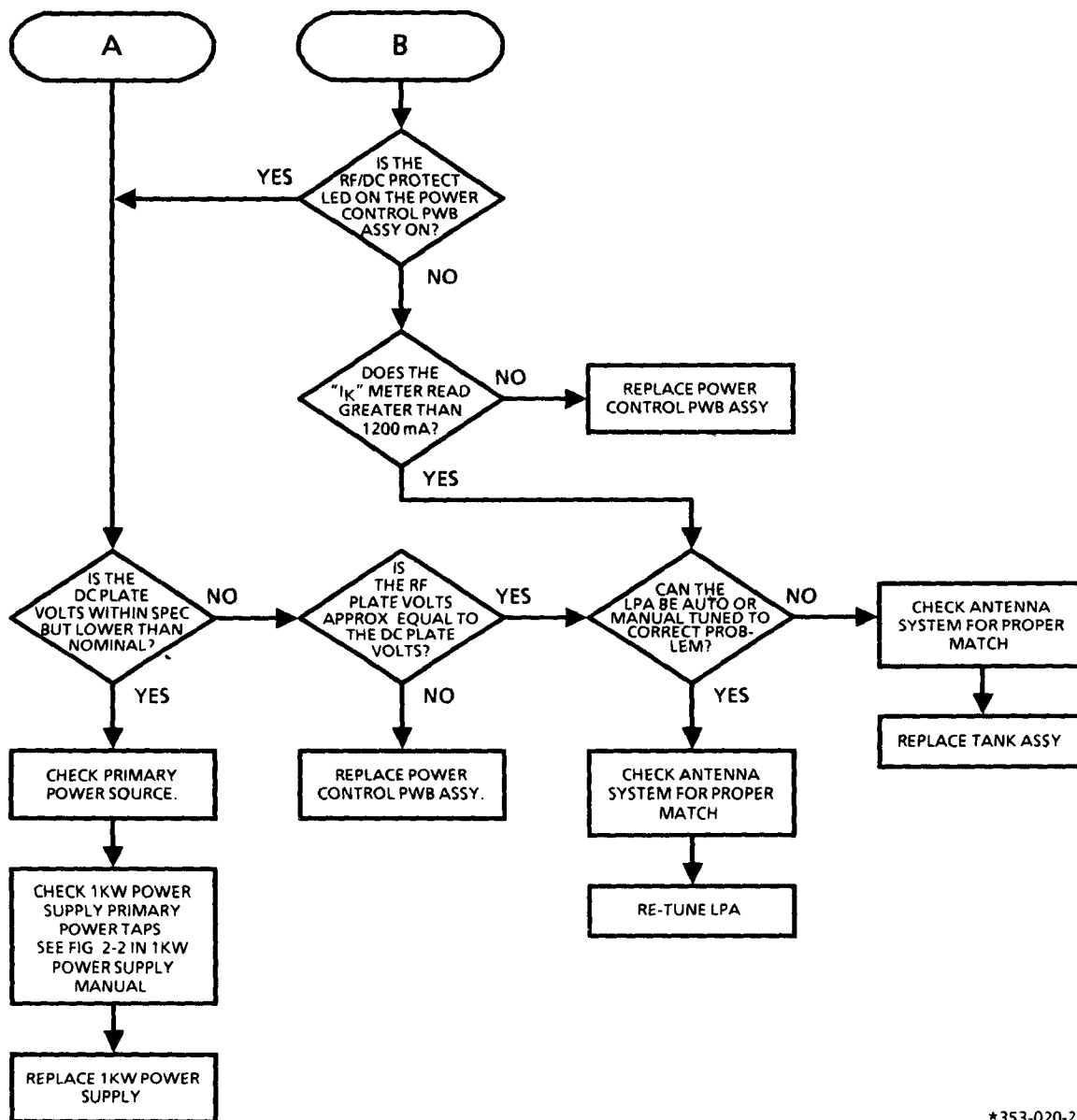

*353-020-2

Figure 6-5. Fault Isolation Chart D (Sheet 2 of 2)

FAULT ISOLATION CHART 2-03

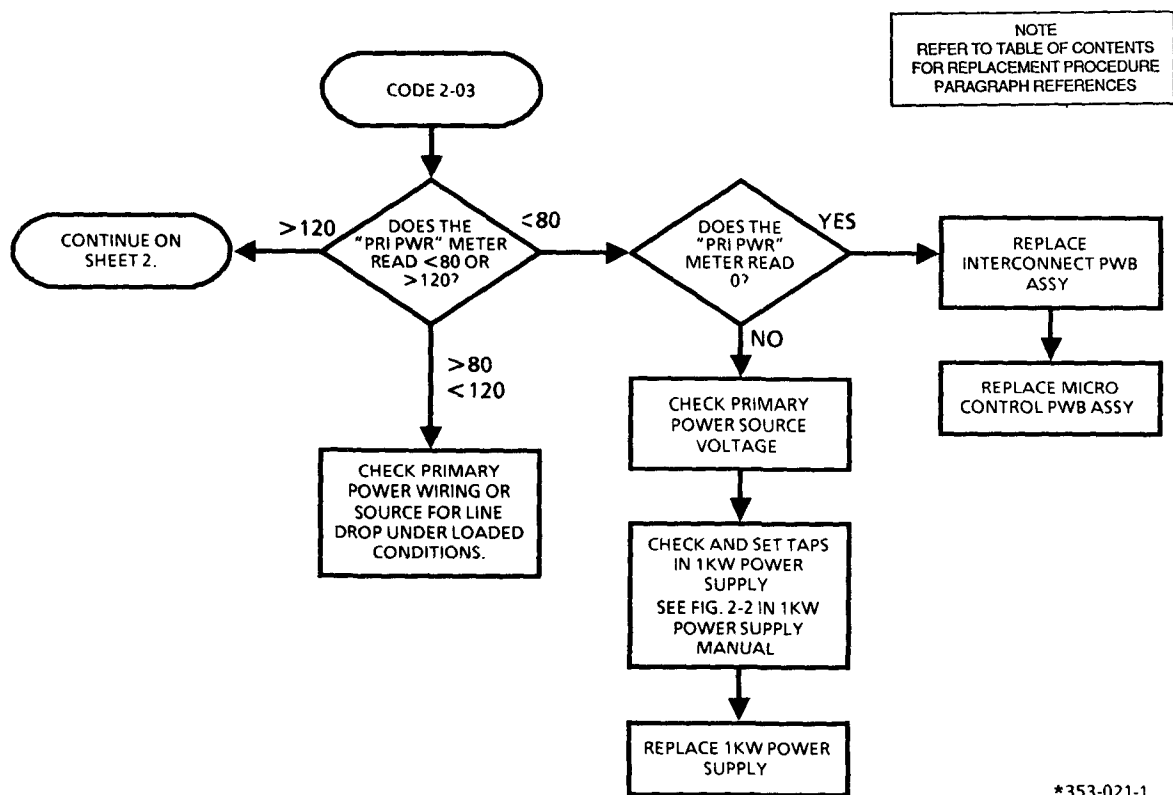

Figure 6-6. Fault Isolation Chart for Fault Code 2-03 (Sheet 1 of 2)

FAULT ISOLATION CHART 2-03 (Cont.)

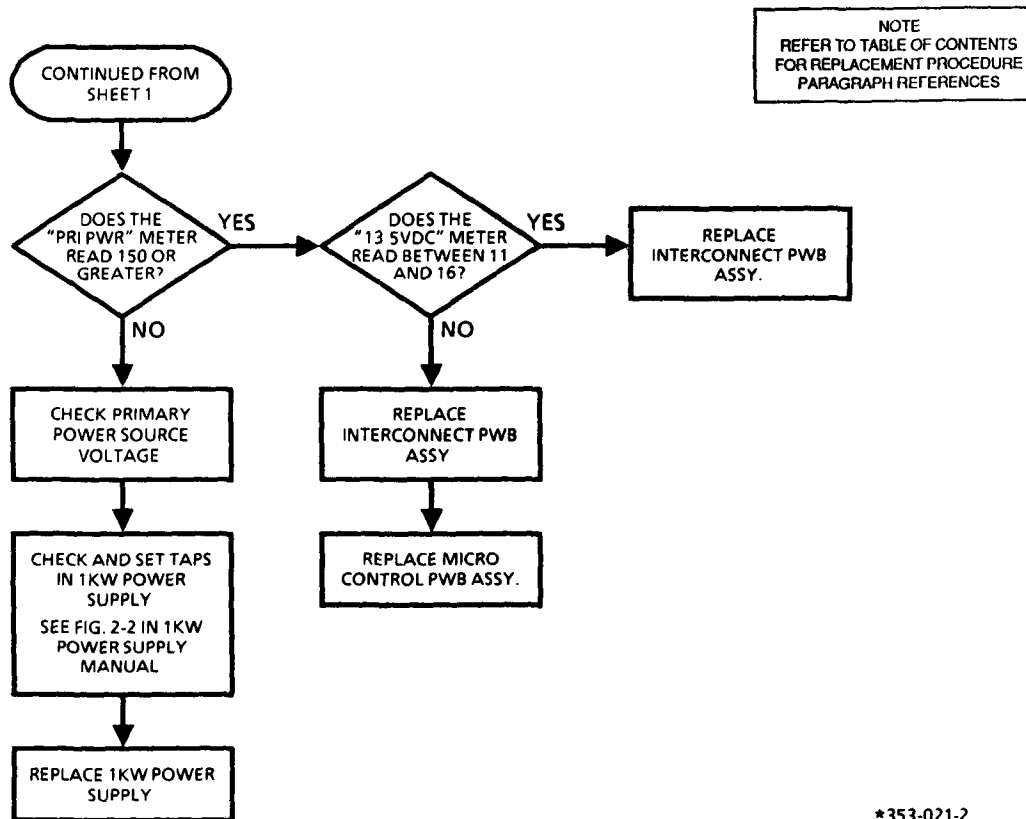
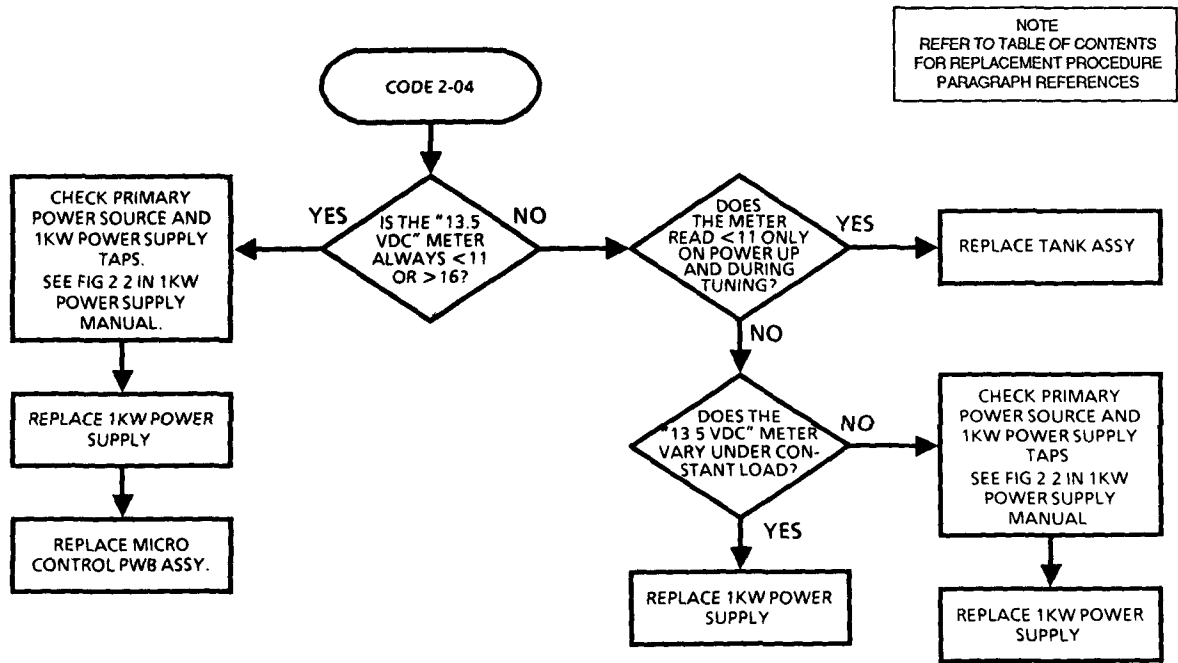

Figure 6-6. Fault Isolation Chart for Fault Code 2-03 (Sheet 2 of 2)

FAULT ISOLATION CHART 2-04



*353-022

Figure 6-7. Fault Isolation Chart for Fault Code 2-04

FAULT ISOLATION CHART 2-05

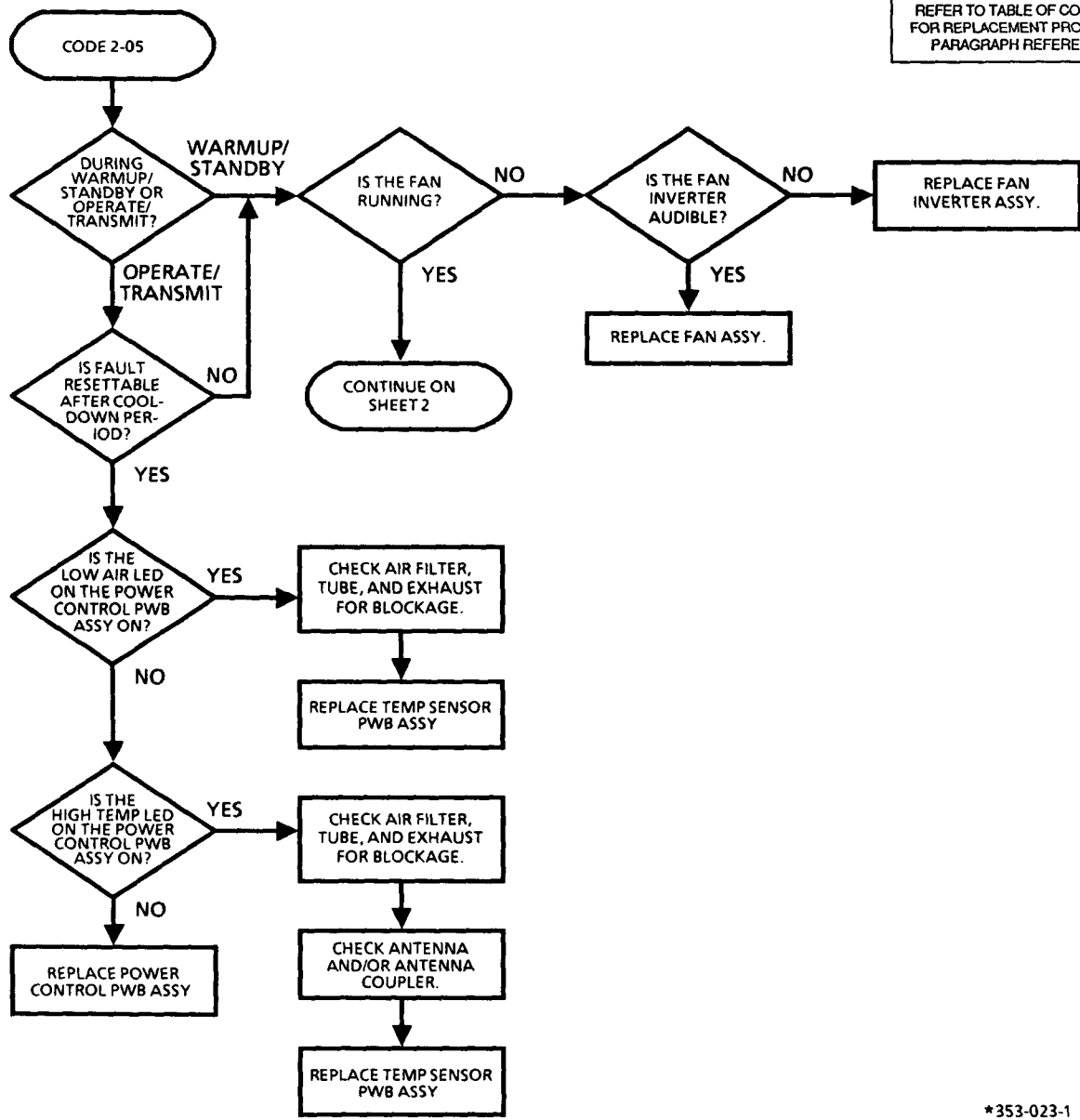

NOTE
REFER TO TABLE OF CONTENTS
FOR REPLACEMENT PROCEDURE
PARAGRAPH REFERENCES

*353-023-1

Figure 6-8. Fault Isolation Chart for Fault Code 2-05 (Sheet 1 of 2)

FAULT ISOLATION CHART 2-05 (Cont.)

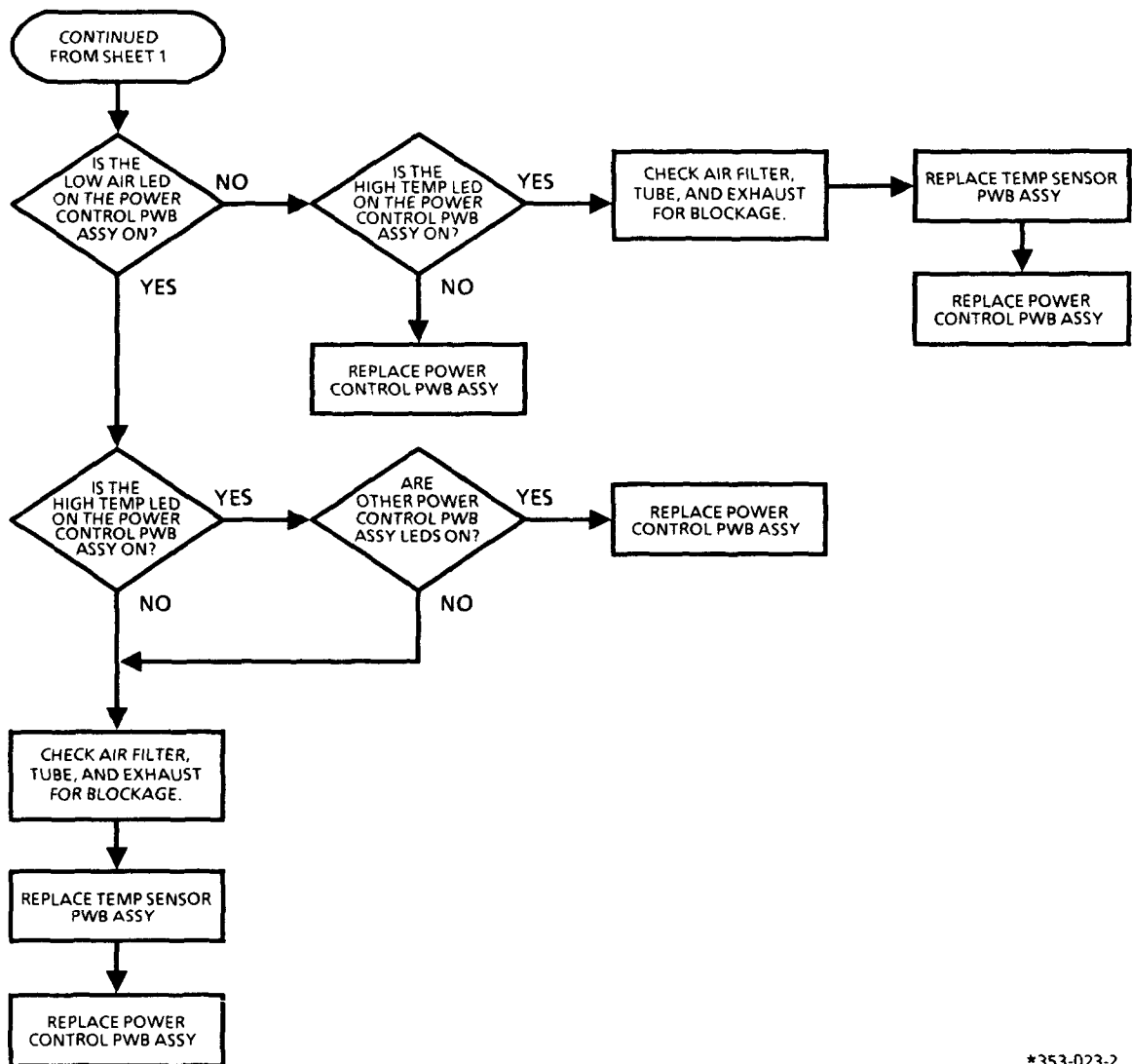

*353-023-2

Figure 6-8. Fault Isolation Chart for Fault Code 2-05 (Sheet 2 of 2)

FAULT ISOLATION CHART 2-08

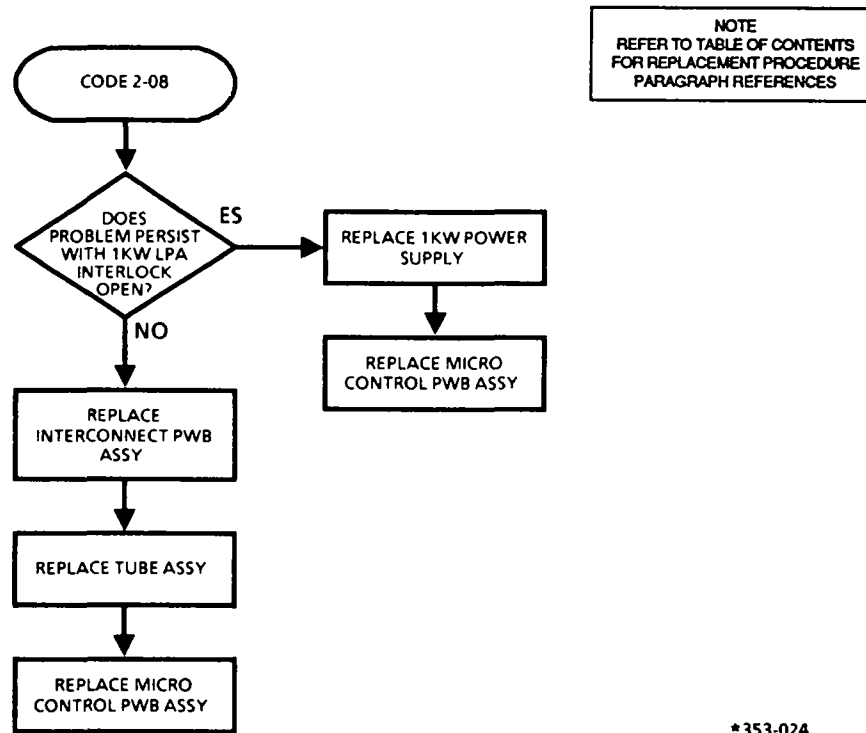
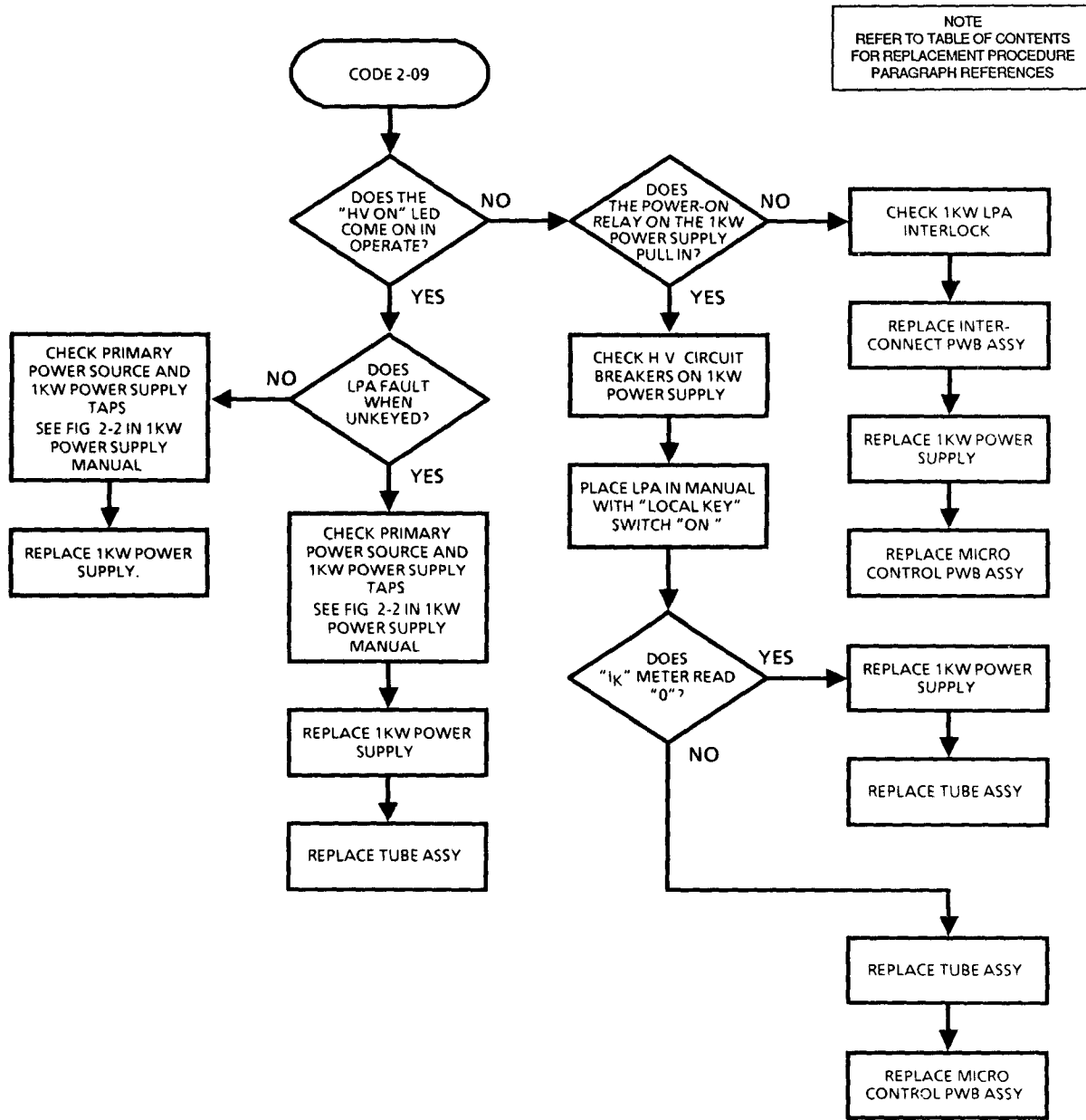

Figure 6-9. Fault Isolation Chart for Fault Code 2-08

FAULT ISOLATION CHART 2-09



*353-025

Figure 6-10. Fault Isolation Chart for Fault Code 2-09

FAULT ISOLATION CHART 2-10

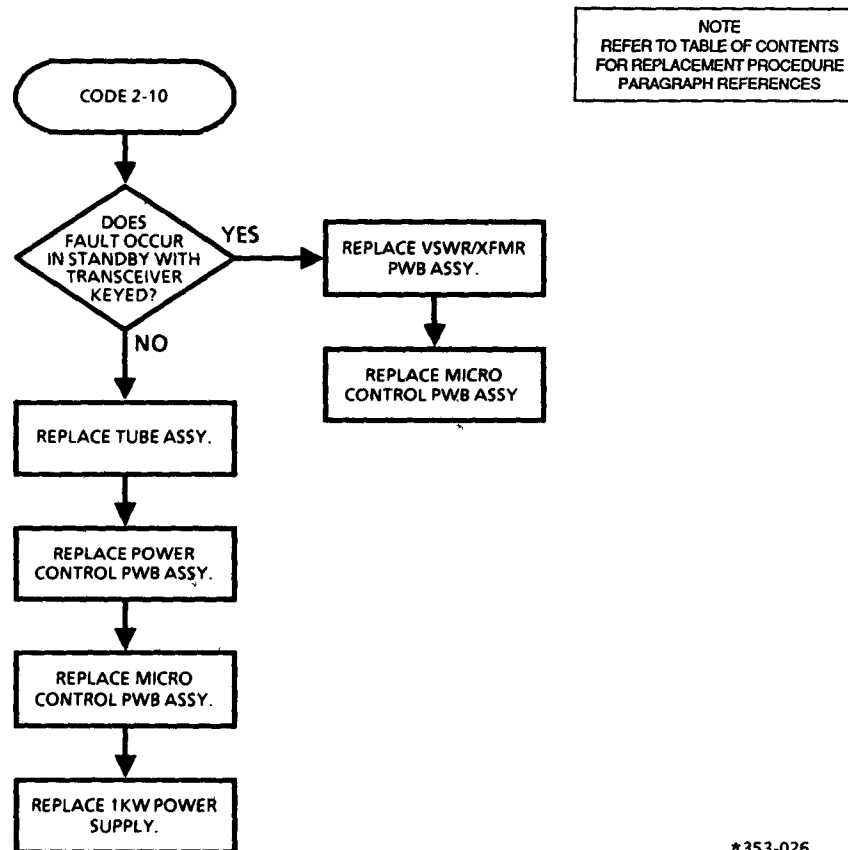

*353-026

Figure 6-11. Fault Isolation Chart for Fault Code 2-10

FAULT ISOLATION CHART 2-11

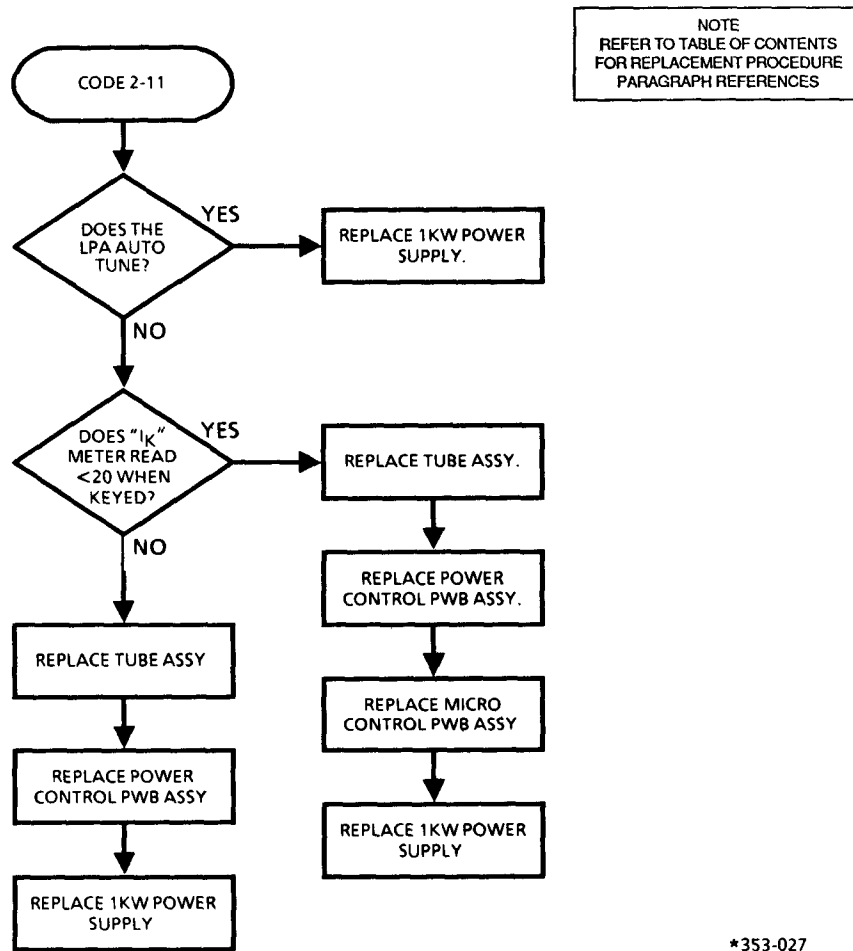

*353-027

Figure 6-12. Fault Isolation Chart for Fault Code 2-11

FAULT ISOLATION CHART 2-13

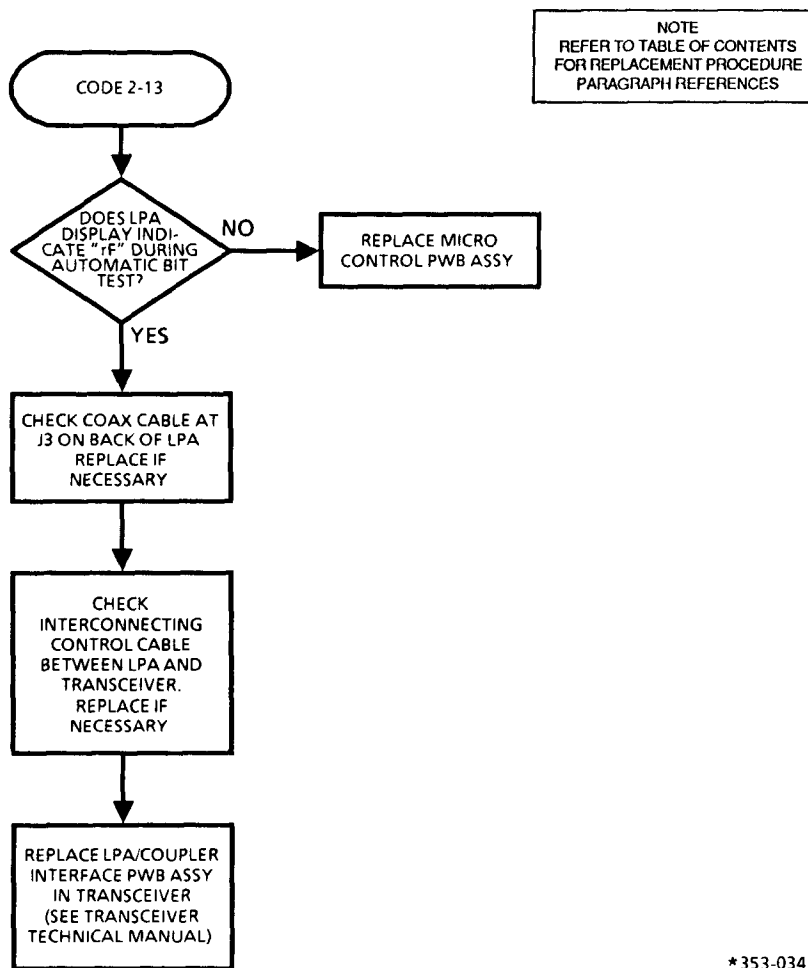
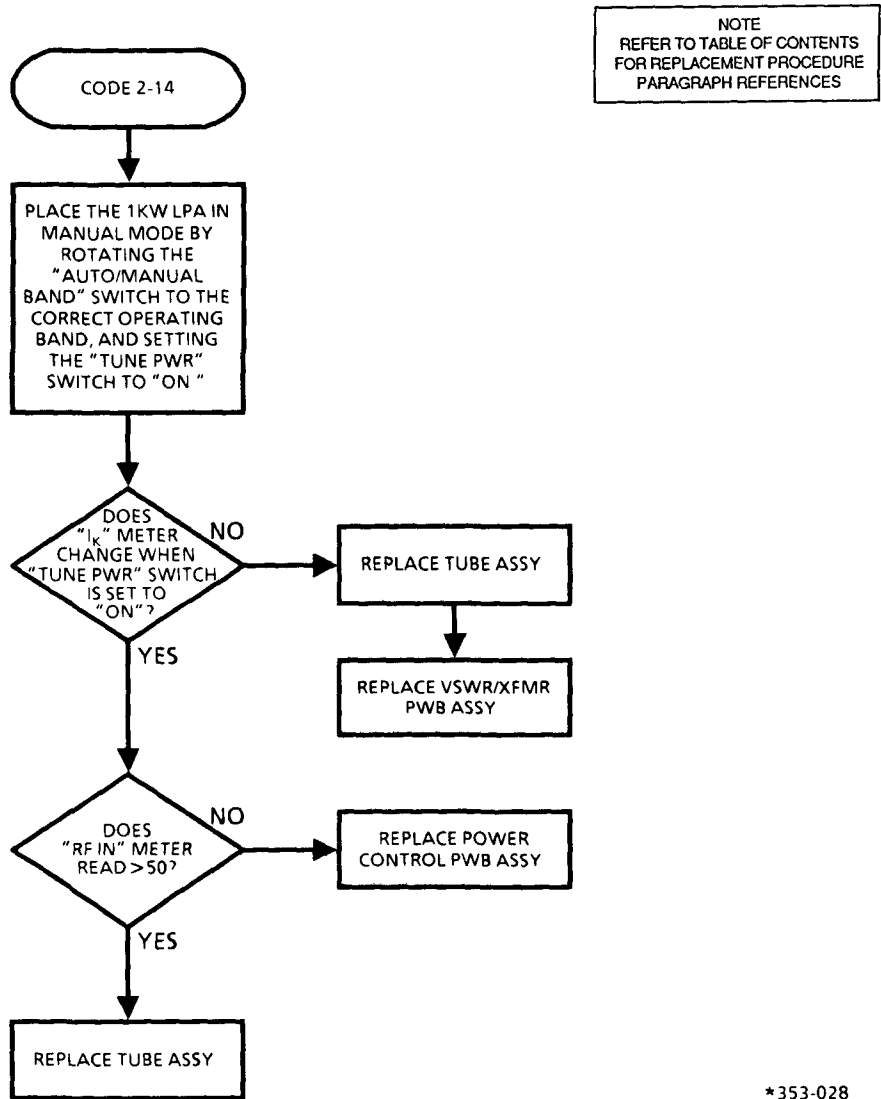

Figure 6-13. Fault Isolation Chart for Fault Code 2-13

FAULT ISOLATION CHART 2-14



*353-028

Figure 6-14. Fault Isolation Chart for Fault Code 2-14

FAULT ISOLATION CHART 2-15

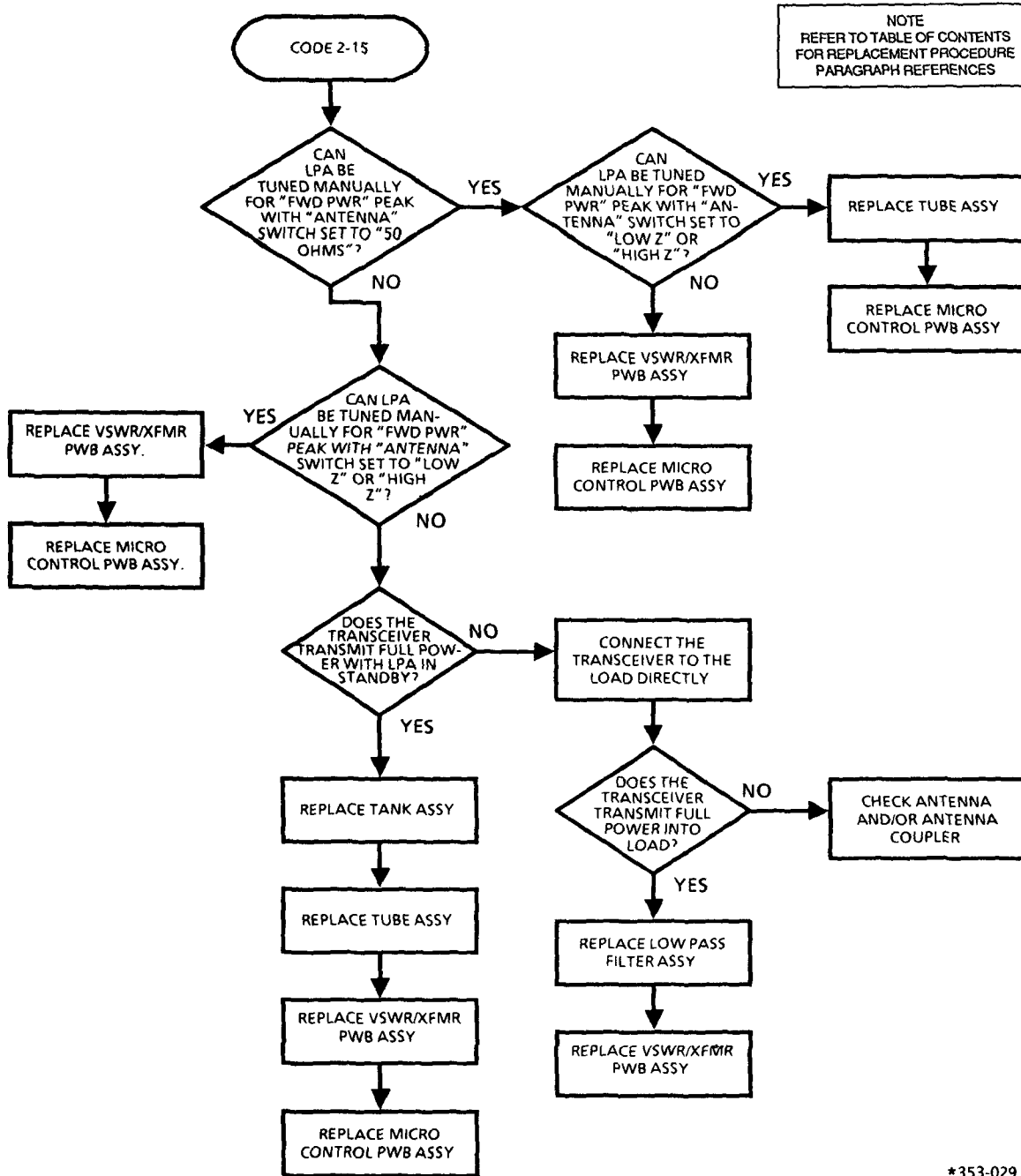

*353-029

Figure 6-15. Fault Isolation Chart for Fault Code 2-15

FAULT ISOLATION CHART 2-16

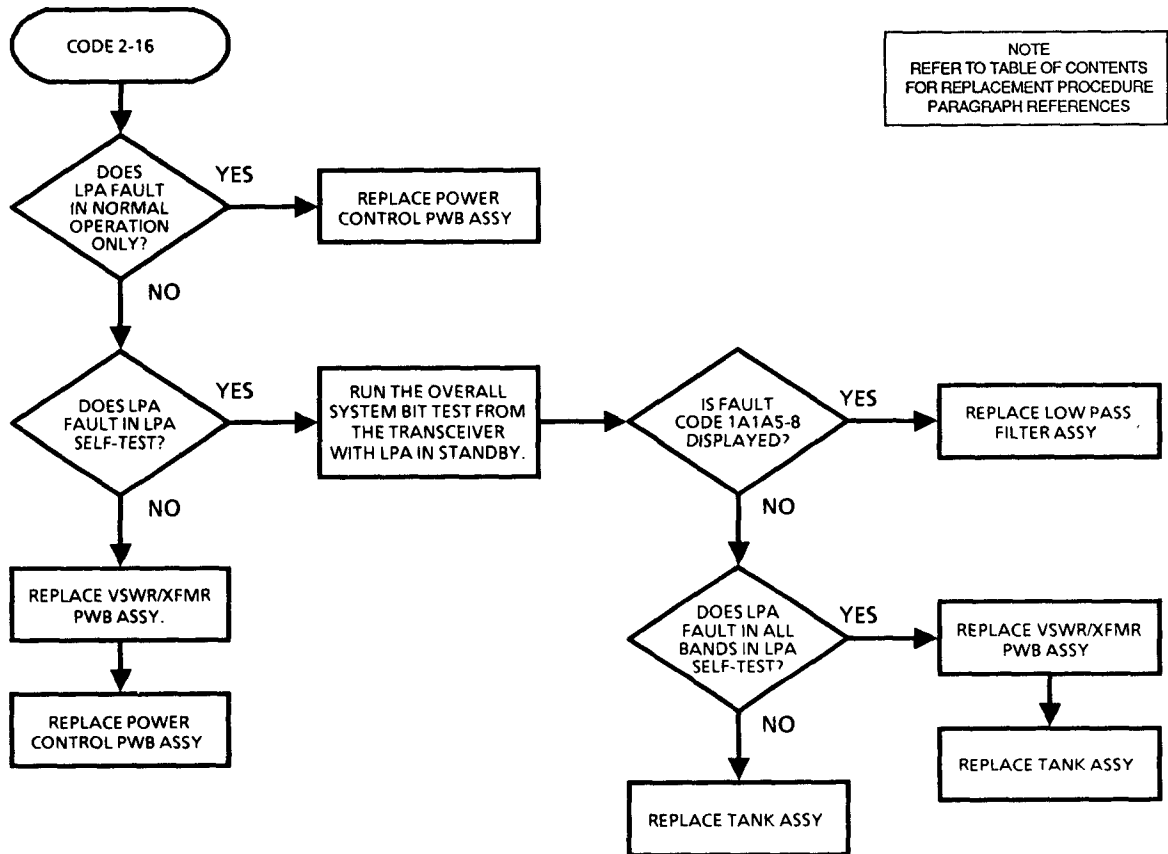

*353-030

Figure 6-16. Fault Isolation Chart for Fault Code 2-16

MAINTENANCE

Section III. REMOVAL/REPLACEMENT PROCEDURES

WARNING

Voltages dangerous to life exist in this radio equipment. Before removing the top cover, disconnect the primary power and wait 30 seconds. This allows time for all voltages to bleed off.

CAUTION

Use care when disconnecting ribbon cables, coax cables, etc.

NOTE

Refer to drawing FO-3 while doing the following procedures. This drawing has an apron which allows you to look at it while reading the procedures. The numbers in parentheses in the procedural steps correspond to the numbered items on the drawing. For example, A30 refers to item 30 on view A.

6-9. TUBE ASSY.

a. Removal.

- (1) Disconnect the input power from the 1 KW Linear Power Amplifier.
- (2) Loosen the two 1/4-turn fasteners (B9), and remove the top cover (B10).
- (3) Disconnect the Tube Assy cable (B11), and remove it from its retainer clip.
- (4) Loosen the three 1/4-turn fasteners (B15) holding the Tube Assy (B16) to the Chassis.
- (5) Remove the Tube Assy.

b. Replacement.

Reverse the order of the above steps.

6-10. TANK ASSY.

a. Removal.

- (1) Disconnect the input power from the 1 KW Linear Power Amplifier.
- (2) Loosen the two 1/4-turn fasteners (B9), and remove the top cover (B10).
- (3) Disconnect the ribbon cable from J1 on the Tank Assy circuit board (B22).
- (4) Disconnect the coax cable at the rear of the Tank Assy (B23).
- (5) Loosen the four 1/4-turn fasteners holding the Tank Assy to the chassis.
- (6) Remove the Tank Assy.

b. Replacement.

Reverse the order of the above steps.

6-11. VSWR/XFMR PWB ASSY.

a. Removal.

- (1) Disconnect the input power from the 1 KW Linear Power Amplifier.
- (2) Disconnect the 1 KW Power Supply cable at J1 on the back of the 1 KW Linear Power Amplifier.
- (3) Loosen the two 1/4-turn fasteners (B9), and remove the top cover (B10).
- (4) Disconnect the coax cables (B25) from the rear of the Tank Assy (B23) and from the connector (B19) on the side of the Low Pass Filter Assy (B20).
- (5) Disconnect the 14-pin connector from the VSWR/XFMR PWB Assy (B27).

- (6) Remove the six Phillips screws (B26) holding the VSWR/XFMR PWB Assy to the rear of the chassis.
- (7) Remove the VSWR/XFMR PWB Assy.

b. Replacement.

Reverse the order of the above steps.

6-12. **FAN INVERTER PWB ASSY.**

a. Removal.

- (1) Disconnect the input power from the 1 KW Linear Power Amplifier.
- (2) Loosen the two 1/4-turn fasteners (B9), and remove the top cover (B10).
- (3) Remove the Tube Assy cable (B11) from its retainer clips, and move it out of the way of the Fan Inverter mounting plate (B12).
- (4) Loosen the two slotted, spring-loaded captive screws (B13) holding the Fan inverter mounting plate.
- (5) Lift up the Fan inverter mounting plate, and disconnect the two cables on the Fan Inverter PWB Assy (B14).
- (6) Loosen the four captive Phillips screws holding the Fan Inverter PWB Assy to the Fan inverter mounting plate.
- (7) Remove the Fan Inverter PWB Assy from the Fan Inverter Mounting plate.

b. Replacement.

Reverse the order of the above steps.

6-13. **POWER CONTROL PWB ASSY.**

a. Removal.



- (1) Disconnect the input power from the 1 KW Linear Power amplifier.
- (2) Loosen the four captive Phillips screws (A30) on the front panel (A1).
- (3) Swing the front panel down into its horizontal position.
- (4) Disconnect the two cables from the Power Control PWB Assy (B7).
- (5) Loosen the five captive Phillips screws (B8) holding the Power Control PWB Assy.

- (6) Remove the Power Control PWB Assy.

b. Replacement.

- (1) Reverse the order of the above steps.
- (2) After installing the Power Control PWB Assy, complete realignment must be accomplished, starting with R34, CW/FSK Power Adjustment, which is normally set fully counterclockwise (full power). Next realign R96, max Plate Current Adjustment to 400 ma, so that the 1 KW Power Amplifier will produce sufficient power to accomplish the realignment. This realignment must be accomplished to bring the Power Control PWB Assy within specifications for use in the 1 KW Power Amplifier. Use the procedures in Section V. Alignment Procedures, Para 6-23. e. Power Control PWB Assy, A5. (See Figure 6-17)

6-14. **MICRO CONTROL PWB ASSY.**

a. Removal.



- (1) Disconnect the input power from the 1 KW Linear Power Amplifier.
- (2) Loosen the four captive Phillips screws (A30) on the front panel (A1).
- (3) Swing the front panel down into its horizontal position.
- (4) Disconnect the ribbon cable from the Front Panel PWB Assy (B3).
- (5) Unhook the front panel support arm (B5), and remove the front panel from the chassis.
- (6) Loosen the six captive Phillips screws (B6) holding the Micro Control PWB Assy (B4) to the chassis.
- (7) Lean the Micro Control PWB Assy forward, and disconnect the ribbon cable from the back.
- (8) Remove the Micro Control PWB Assy.

b. Replacement.

Reverse the order of the above steps.

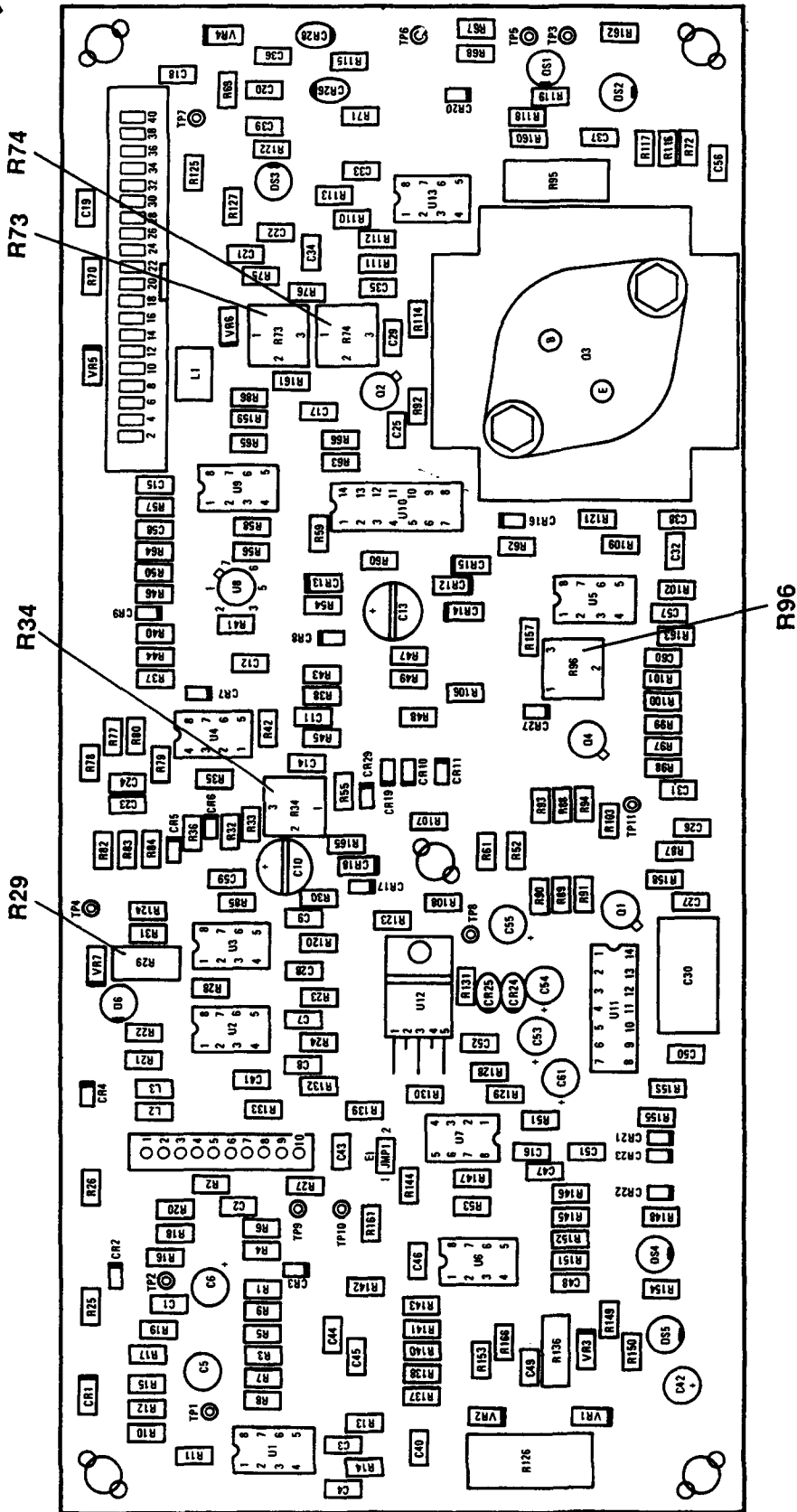

Figure 6-17. Power Control PWB Assy

6-15. FRONT PANEL PWB ASSY.**a. Removal**

- (1) Disconnect the input power from the 1 KW Linear Power Amplifier.
- (2) On the front panel (A1), remove the retaining nuts, washers, and lock washers from the five toggle switches and from the SELF TEST pushbutton switch.
- (3) Remove the knobs from the AUTO/MANUAL BAND and METER rotary switches. Each knob is secured by two setscrews. Remove the nuts and lock washers from the switches.
- (4) Loosen the four captive Phillips screws (A30) on the front panel.
- (5) Swing the front panel down into its horizontal position.
- (6) Remove the two Phillips screws (B2) and the lock washers holding the Front Panel PWB Assy (B3).
- (7) Disconnect the ribbon cable from the Front Panel PWB Assy.
- (8) Remove the Front Panel PWB Assy.

b. Replacement.

Reverse the order of the above steps.

6-16. TEMP SENSOR PWB ASSY.**a. Removal.**

- (1) Remove the Tube Assy (B16). Follow the procedure in paragraph 6-13.
- (2) Remove the two Phillips mounting screws for the Temp Sensor PWB Assy.
- (3) Disconnect the cable from the Temp Sensor PWB Assy.
- (4) Remove the Temp Sensor PWB Assy.

b. Replacement

Reverse the order of the above steps.

6-17. INTERCONNECT PWB ASSY.**a. Removal.**

- (1) Disconnect the three cables from the Interconnect PWB Assy (B24).
- (2) Loosen the two captive Phillips screws holding the Interconnect PWB Assy to the chassis.
- (3) Remove the Interconnect PWB Assy.

b. Replacement.

Reverse the order of the above steps.

6-18. LOW PASS FILTER ASSY.**a. Removal.**

- (1) Remove the Tube Assy (B16). Follow the procedure in paragraph 6-13.
- (2) Disconnect the coax cables from the antenna connector (J5 at the rear of the chassis) and the internal coax connector (B19) on the Low Pass Filter Assy (B20).
- (3) Remove the six Phillips screws holding the Low Pass Filter Assy to the chassis (two of these are at the J5 antenna connector).
- (4) Remove the Low Pass Filter Assy.

b. Replacement.

Reverse the order of the above steps.

6-19. FAN ASSY.**a. Removal.**

- (1) Remove the Tube Assy (B16). Follow the procedure in paragraph 6-13.
- (2) Remove the Tube Assy cable (B11) from the retainer clip on top of the Fan Inverter mounting plate (B12). Move the cable out of the way.

T.O. 31R2-2URC-121

- (3) Loosen the two slotted, spring-loaded captive screws holding the Fan Inverter mounting plate.
- (4) Lift up the Fan Inverter mounting plate, and disconnect the two cables from the Fan Inverter PWB Assy (B14).
- (5) Set the Fan Inverter mounting plate aside.
- (6) Loosen the four captive Phillips screws (A30) on the front panel (A1).
- (7) Swing the front panel down into its horizontal position.
- (8) Remove the four Phillips screws holding the Fan Assy (B18) to the chassis.

(9) Remove the Fan Assy.

b. Replacement.

Reverse the order of the above steps.

6-20. AIR FILTER.

- a. Removal. Remove the air filter by grasping it between your fingers and pulling it out.
- b. Replacement. Push the filter back in along the edges of the front panel (A1) cutout.
- c. Cleaning. Wash the filter (A31) in a solution of mild soap and water, dry, and replace.

Section IV. PERIODIC MAINTENANCE PROCEDURES

6-21. PERIODIC MAINTENANCE ACTIONS.

The 1KW Linear Power Amplifier requires only a limited amount of periodic maintenance. The following actions are recommended at the intervals listed. During any of the specific procedures listed, take note of any unusual equipment conditions which may indicate degrading or degraded performance, and make the necessary corrections.

a. Front Panel Meter Readings.

Every 56 days of equipment operation, check and observe all front panel meter readings. Observe that they are within normal limits and that no degradation of parameters is noted.

b. Clean Air Filter. Clean the equipment air filter every 56 days of 24-hour continuous equipment operation, or sooner if filter is noticeably soiled. Use soap and water; dry thoroughly before replacing.c. Lubricate Tank Assy. Every 168 days of equipment operation, or 500 tune cycles, whichever comes first, the Tank Assy A1A2 should be lubricated. See paragraph 6-10 for tank assembly removal. Do the following:

- (1) Clean the coil turns, coil shafts, and the electrical

contacts on the coil shafts with isopropyl alcohol.

- (2) Apply a light coat of Dow Corning DC 44(FSCM 71984) silicone lubricant to the coil turns using a soft, lint-free cloth. The lubricant should be invisible to the naked eye but sufficient to make the turns feel slippery.

- (3) Apply a heavier, slightly visible coating to each of the electrical contact shafts and to the spring contact shafts. Some lubricant buildup, after running the coil, is acceptable.

- (4) Apply one drop of Anderol 401D (FSCM 99559) instrument oil (or equivalent silicone oil) to each of the oilite bushings in the coil end plates. It is not necessary to apply lubricant to the nylon gears.

- d. Dust Accumulation. Check the tube fins on the Tube Assy for dust accumulation every 56 days. Remove any excessive accumulation as required.

Section V. ALIGNMENT PROCEDURES

6-22. INTRODUCTION. This section contains instructions for checking and adjusting the replaceable subassemblies in the 1KW LPA. This section also contains circuit board layouts to help you

identify the components that can be adjusted. To do the procedures described in this section, you need the test equipment listed in Table 6-3.

Table 6-3. Test Equipment

Generic Name	Military Designation	Manufacturer, Model No.	Federal Stock No.	Required Range
Electronic Voltmeter w/ AC Probe & T-connector		Hewlett Packard, Model 410C Model 11036A Model 11042A		20 to 224 V rms; 1.6 to 30 MHz (peak reading)
Digital Multimeter		Fluke, Model 8012A		200 mV to 250 Vac; 200 mV to 40 Vdc; 0 to 20 megohms
Dummy Load		Bird, Model 8833		1000 W, 50 ohms

NOTE: Equivalent Items Authorized

6-23. ALIGNMENT PROCEDURES

a. TUBE ASSY, A1

R3, RF Plate Sample Adjustment

NOTE

This adjustment assumes the following initial conditions:

- The LPA has been turned off for a least 10 seconds.
 - The LPA's AUTO/MANUAL BAND Switch is in the AUTO position.
- (1) Using a Model 11042A T-connector, connect an HP-410C Voltmeter (or equivalent) between the LPA's RF output connector J5 and a dummy load.

- (2) Remove the top cover from the LPA, and puff the interlock switch all the way up to the "cheat" position.
- (3) Turn the LPA on and set the operating frequency at the transceiver to 7.0000 MHz in CW mode. After the LPA has warmed up (is in STANDBY), place LPA IN OPERATE and tune the system.
- (4) Place the LPA in Manual mode with the AUTO/MANUAL BAND Switch in the 6-8 position. Set the ANTENNA Switch to the 50 ohm position and the LOCAL KEY Switch to ON. Key the transceiver, and monitor the voltage on the RF voltmeter.
- (5) With a reading of 223 ± 2 Vac on the meter, adjust R3 (accessible through a hole in the Tube Assy near the connector--see figure 6-18) so that the RF PLATE (VOLTS) position on the LPA front panel meter reads 2100 ± 20 .

b. TANK ASSY., A2

No adjustments

c. VSWR/XFMR PWB ASSY., A3

(1) R5, Null Adjustment.

NOTE

This adjustment assumes the following initial conditions:

- The LPA has been turned off for at least 10 seconds.
- The LPA'S AUTO/MANUAL BAND Switch is in the AUTO position.
- (a) Connect the 1KW LPA antenna connector J5 to a dummy load.
- (b) Remove the top cover from the LPA, and pull the interlock switch all the way up to the "cheat" position.
- (c) Lower the LPA front panel to its horizontal position to gain access to the Power Control PWB Assy.
- (d) Connect a digital multimeter between test point TP2 and ground on the Power Control PWB Assy (see figure 6-19).
- (e) Turn the LPA on and set the operating frequency at the transceiver to 16.0000 MHz in CW mode. After the LPA has warmed up (is in STANDBY), place the LPA in OPERATE and tune the system.
- (f) Key the system and adjust R5 (on the VSWR/XFMR PWB Assy -- see figure 6-20) for a null (minimum voltage) on the multimeter.

(2) R8, Forward Power Sample

NOTE

This adjustment assumes the following initial conditions:

- The LPA has been turned off for at least 10 seconds.
- The LPA'S AUTO/MANUAL BAND Switch is in the AUTO position.
- (a) Using a Model 11042A T-connector, and a Model 11036A AC Probe, connect an HP-410C Voltmeter (or equivalent) between the LPA's RF output connector J5 and a dummy load.
- (b) Remove the top cover from the LPA, and pull the interlock switch all the way up to the "cheat" position.
- (c) Lower the LPA front panel to its horizontal position to gain access to the Power Control PWB Assy.
- (d) Connect a digital multimeter between test point TP1 and ground on the A5 Power Control PWB Assy (see figure 6-19).
- (e) Turn the LPA on and set the operating frequency at the transceiver to 16.0000 MHz in CW mode. After the LPA has warmed up (is in STANDBY), place the LPA in OPERATE and tune the system.
- (f) Key the system and observe the output voltage on the HP-410C and the forward power sample voltage on the digital multimeter. The HP-410C should read 223 Vac and the multimeter should read 7.00 Vdc.
- (g) If both read higher or both read lower than the above voltages, adjust the Loop Gain Potentiometer R29 on the Power Control PWB Assy so that the HP-410C reads 223 Vac. Observe the voltage on the multimeter.
- (h) If the multimeter reads 7.0000 ± 0.05 Vdc, no adjustment of R8 is required.
- (i) If the reading on the multimeter is less than 6.95Vdc, adjust R29 on the Power Control PWB Assy for a reading of slightly less than 223 Vac on the HP-410C. Then adjust R8 for a reading of 223 Vac on the HP-410C. Continue this procedure until the

multimeter voltage is 7.00 ± 0.05 Vdc when the HP-410C voltage is 223 ± 2 Vac.

- (j) If the reading on the multimeter is more than 7.05 Vdc, adjust R8 for a reading of slightly less than 6.95 Vdc on the multimeter. Readjust R29 on the Power Control PWB Assy for 223 Vac on the HP-410C. Continue this procedure until the multimeter voltage is 7.00 ± 0.05 Vdc when the HP-410C voltage is 223 ± 2 VAC.

(3) R6, Reflected Sample Adjustment

NOTE

This adjustment assumes the following initial conditions:

- The LPA has been turned off for at least 10 seconds.
 - The LPA's AUTO/MANUAL BAND Switch is in the AUTO position.
 - R5 and R8 on the VSWR/XFMR PWB Assy are correctly adjusted.
- (a) Connect the LPA's RF output connector J5 to a dummy load.
 - (b) Remove the top cover from the LPA, and pull the interlock switch all the way up to the "cheat" position.
 - (c) Lower the LPA front panel to its horizontal position to gain access to the Power Control PWB Assy.
 - (d) Connect a digital multimeter between test points TP1 and TP2 on the A5 Power Control PWB Assy (see figure 6-19).

- (e) Turn the LPA on and set the operating frequency at the transceiver to 16.0000 MHz in CW mode. After the LPA has warmed up (is in STANDBY), place the LPA in OPERATE and tune the system.

NOTE

Dummy load must be disconnected for this test because reflected power is being measured. Radio AMP does have self protection circuit to prevent damage to final LPA.

- (f) Unkey the system if keyed and disconnect the dummy load from the J5 antenna connector.
- (g) Key the system, and adjust R6 for 0.00 ± 0.05 Vdc on the digital multimeter.

d. FAN INVERTER PWB ASSY., A4

No adjustments.

e. POWER CONTROL PWB ASSY., A5

(1) R29, Loop Gain Control

NOTE

This adjustment assumes the following initial conditions:

- The LPA has been turned off for at least 10 seconds.
- The LPA's AUTO/MANUAL BAND Switch is in the AUTO position.
- R5, R6, and R8 on the VSWR/XFMR PWB Assy are correctly adjusted.

- (a) Using a Model 11042A T-connector, connect an HP-410C Voltmeter (or equivalent) between the LPA's RF output connector J5 and a dummy load.
- (b) Lower the LPA front panel to its horizontal position in order to gain access to the Power Control PWB Assy.
- (c) Adjust Power Control Potentiometer R74 on the Power Control PWB Assy fully clockwise, and adjust R34 fully counterclockwise.
- (d) Turn the LPA on and set the operating frequency at the transceiver to 16.0000 MHz in CW mode. After the LPA has warmed up (is in STANDBY), place the LPA in OPERATE and tune the system.
- (e) Key the system and adjust the Loop Gain Control R29 for a reading of 223 to 230 Vac on the HP-410C.

(2) R34, CW/FSK Power Adjustment

This adjustment is normally set fully counterclockwise in the 1 KW LPA. If

reduced power is required in the CW or FSK mode, then the required reduced power output may be obtained by adjusting R34 in a clockwise direction during normal operation.

(3) R73, Coupler Tune Power Adjustment

NOTE

This adjustment assumes the following initial conditions:

- The LPA has been turned off for at least 10 seconds.
- The LPA's AUTO/MANUAL BAND Switch is in the AUTO position.
- R5, R6, and R8 on the VSWR/XFRM PWB Assy are correctly adjusted.
- (a) Connect the LPA's RF output connector J5 to a dummy load.
- (b) Lower the LPA front panel to its horizontal position in order to gain access to the Power Control PWB Assy.
- (c) Turn the LPA on and set the operating frequency at the transceiver to 16.0000 MHz in CW mode. After the LPA has warmed up (is in STANDBY), place the LPA in OPERATE and tune the system.
- (d) Connect a ground to the J1-5 side of R121 on the Power Control PWB Assy (see figure 6-19). This will place the Power Control PWB Assy into the coupler tune mode.
- (e) Set the LPA meter select switch on the front panel to the FWD PWR (WATTS) position and key the system. Adjust R73 on the Power Control PWB Assy for 200 watts on the front panel meter.
- (f) Unkey the system and remove the ground from R121.

(4) R74, Power Control Adjustment

This potentiometer is normally set fully clockwise. If reduced output power is required in all modes, then this is accomplished by adjusting R74 counterclockwise until the desired output power is attained.

(5) R96, Max Plate Current Adjustment

NOTE

This adjustment assumes the following initial conditions:

- The LPA has been turned off for at least 10 seconds.
- The LPA's AUTO/MANUAL BAND Switch is in the AUTO position.
- R5, R6, and R8 on the VSWR/XFMR PWB Assy are correctly adjusted.
- (a) Connect the LPA's RF output connector J5 to a dummy load.
- (b) Lower the LPA front panel to its horizontal position in order to gain access to the Power Control PWB Assy.
- (c) Turn the LPA on and set the operating frequency at the transceiver to 16.0000 MHz in CW mode. After the LPA has warmed up (is in STANDBY), set the LPA's AUTO/MANUAL BAND Switch to the 16-24 position.
- (d) Set the TUNE PWR Switch to the ON position, and set the METER Switch to the 1 μ (mA) position.
- (e) Adjust R96 on the PWB Assy for 400 \pm 8 on the front panel meter.
- f. MICRO CONTROL PWB ASSY., A6
No adjustments
- g. FRONT PANEL PWB ASSY., A7A1
No adjustments.
- h. TEMP SENSOR PWB ASSY., A8

NOTE

This adjustment can be performed on a "cold" LPA (one that has been turned off for at least 15 minutes) or a "hot" LPA (one that has been turned on for more than 10 seconds). If you remove the JMP1 jumper (on the Power Control PWB Assy) from a cold LPA, you can begin the adjustment procedure immediately (as soon as you turn the LPA on). However, if you remove the jumper from an LPA that has been on for more than 10 seconds, then you should allow 15 minutes for the temperature sensors to stabilize at ambient before doing the adjustment.

- (1) Lower the LPA front panel to its horizontal position to gain access to the Power Control PWB Assy.
- (2) Remove JMP1 (PN65474-001) on the Power Control PWB Assy (see figure 6-19).

- (3) With the LPA in warmup (for a cold LPA) or standby (for a hot LPA), connect a digital multimeter between test points TP9 and TP10 on the Power Control PWB Assy.
- (4) If the voltage on the multimeter is 0 ± 2 mV, no adjustment is necessary. If not, adjust R2 (R2 is accessible through the rear grille of the LPA--see figures 6-18 and 6-21) until the voltage is within the limits.
- (5) Re-install JMP1 on the Power Control PWB Assy.

i. INTERCONNECT PWB ASSY., A9

No adjustments.

j. LOW PASS FILTER ASSY., A10

No adjustments.

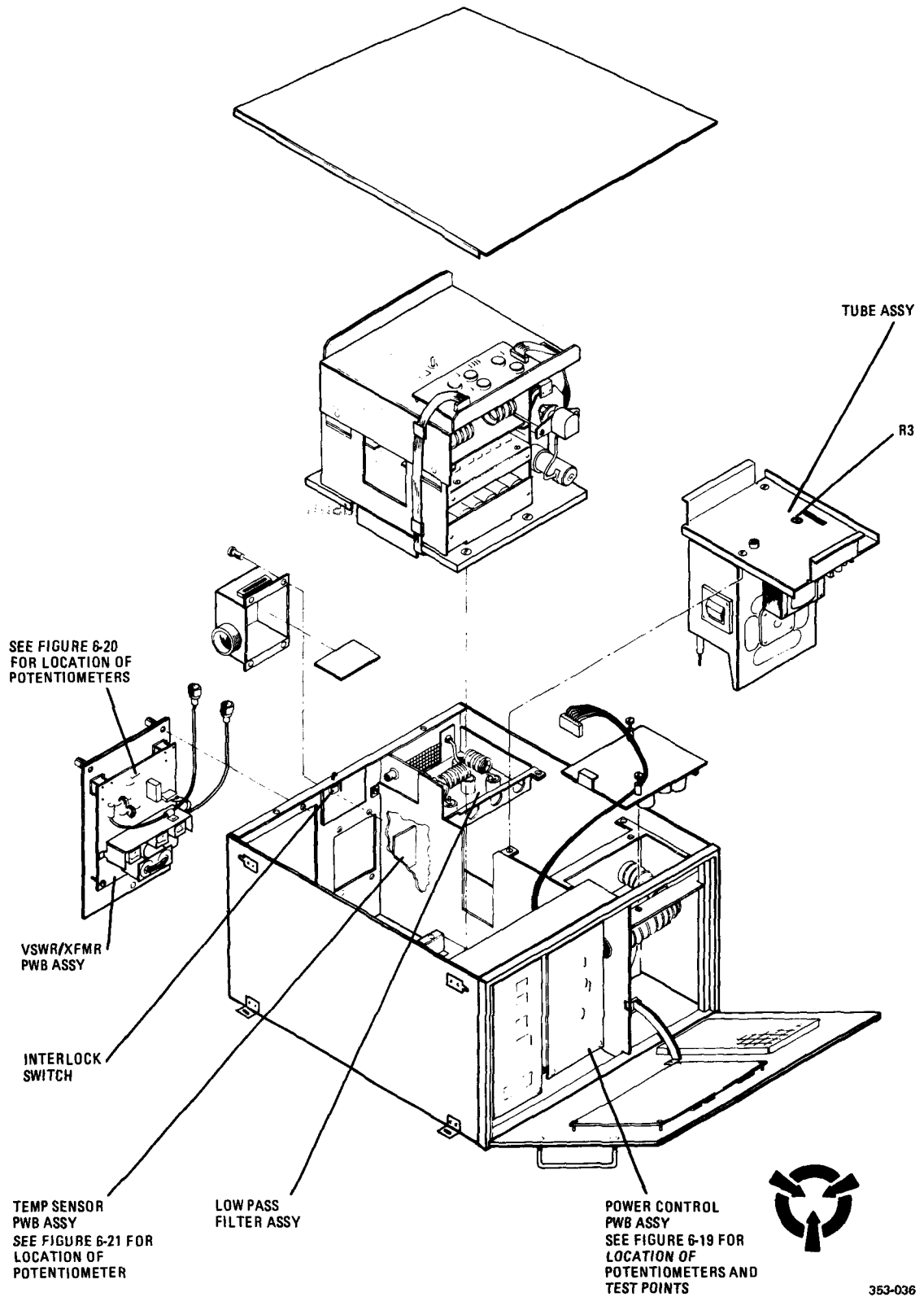

Figure 6-18 1 KW LPA

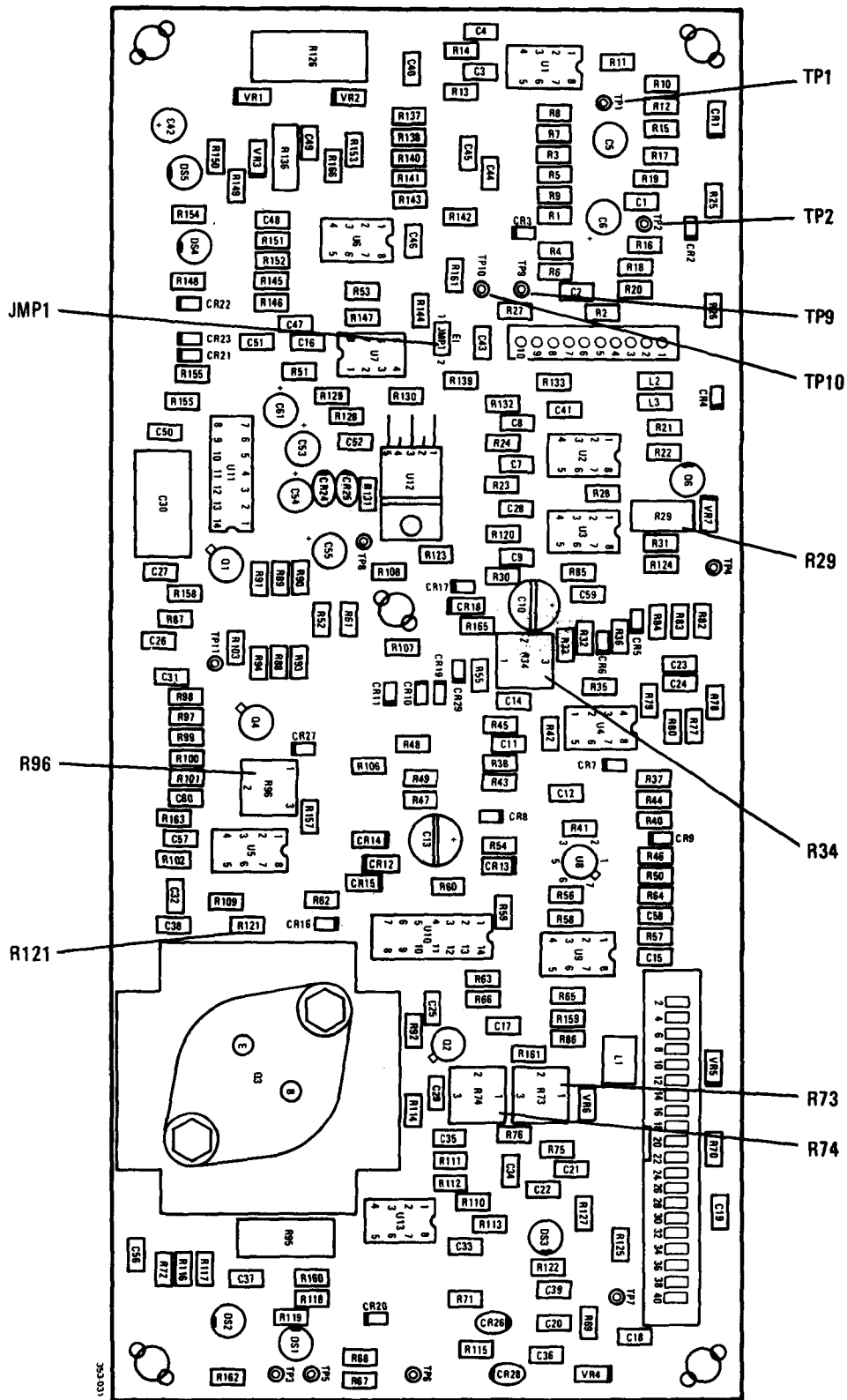
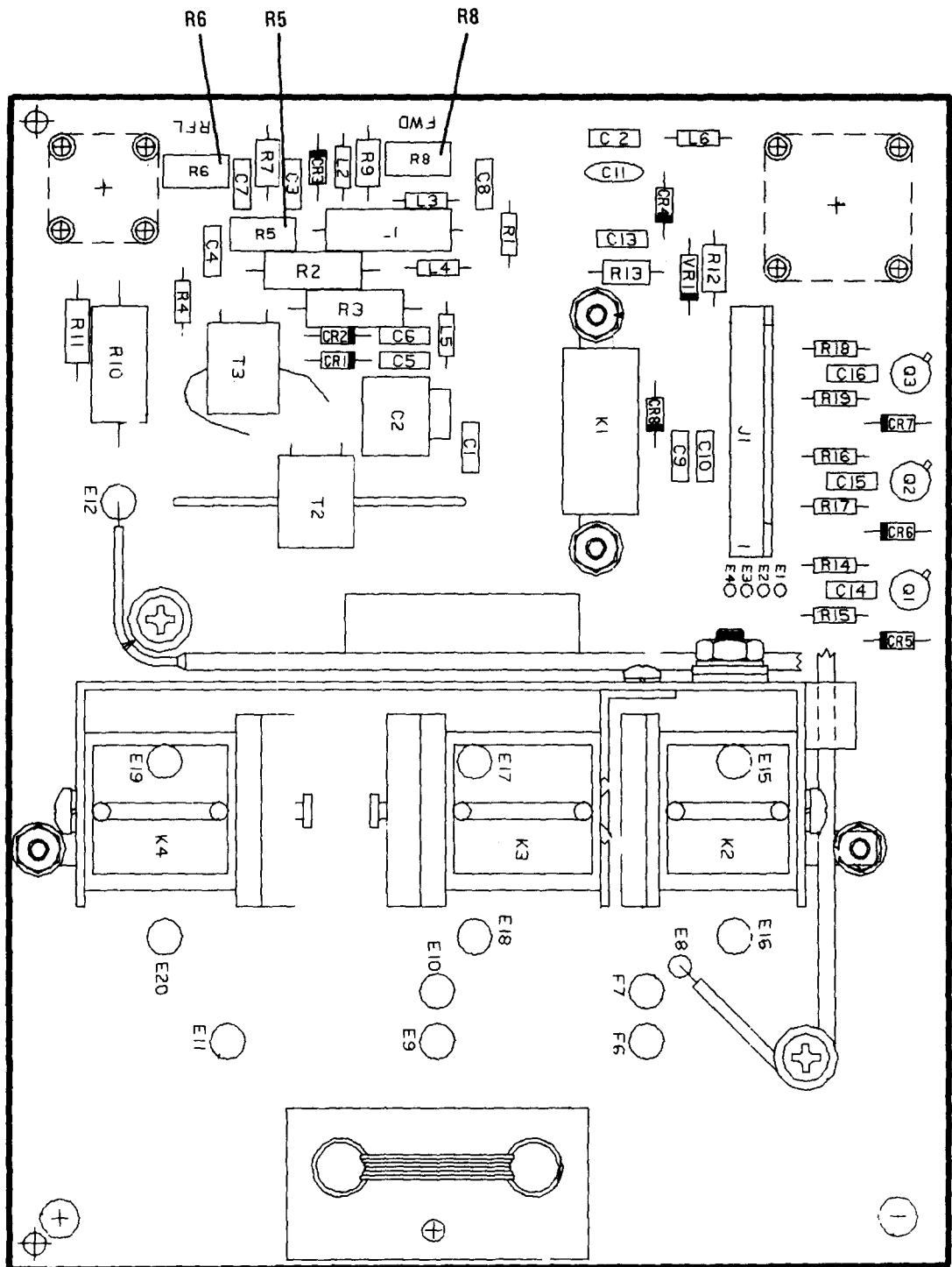
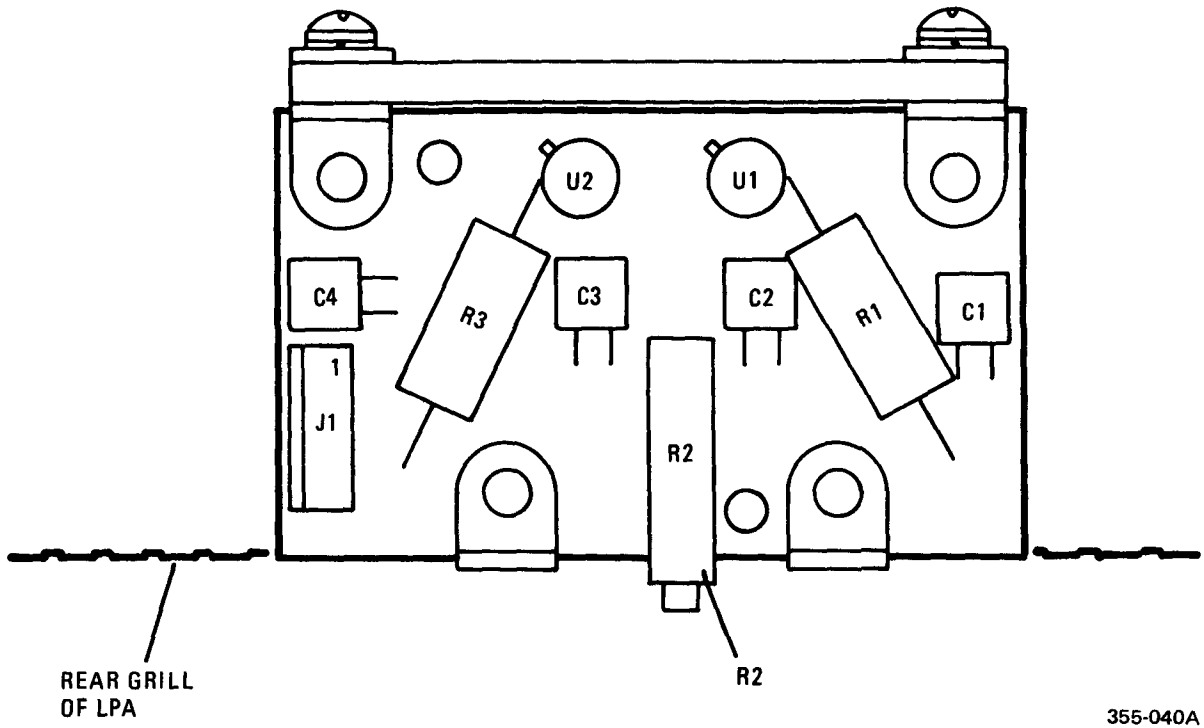

Figure 6-19. Power Control PWB Assy



353-037A

Figure 6-20. VSRW/XFMR PWB Assy



355-040A

Figure 6-21. Temp Sensor PWB Assy

APPENDIX

CHECKS PERFORMED DURING THE AUTOMATIC BIT ROUTINE FOR THE 1 KW LPA

NOTE

If BIT is initiated during WARMUP, only the tests up to and including the Band Switch/Servo Coil Test are performed.

1. Front Panel Test. At the start of the test, the front panel is disabled and remains so for the remainder of the test. Also at the start of the test, all front panel LCD segments and LED indicators are turned on. They stay on for the remainder of the test with the exception of the condition when tune power is requested from the 100 Watt Transceiver (see "Keying Test").

2. Micro Control Test. The microprocessor is checked. If its operation is determined to be incorrect, FAULT 2-01 is declared.

3. Primary Power Test. The primary power level is sampled. If it is not between 80 and 120% of the nominal value, FAULT 2-03 is declared.

4. Low Voltage Supply Test. The 13.5 V supply is sampled. If it is not between 10 and 16 Vdc, FAULT 2-04 is declared.

5. Transmitter Fault Test. If the XMTR-FAULT signal line (temperature sensor) is active, FAULT 2-05 is declared.

6. Band Switch/Servo Coil Test. For this test, a band other than the current operating band is selected for the band switch. Once this position is reached, the switch returns to the current operating band position. If the switch does not turn, or if it takes over 10 seconds to reach the selected band, FAULT 2-06 is declared. The coil is moved to MIN L and then to MAX L, and the coil position counter is checked at both limits. If the coil does not move, or if the position counter is inaccurate, FAULT 2-07 is declared. If the 1 KW LPA is in WARMUP, no further testing is done.

7. High Voltage Test. With the 1 KW LPA in STANDBY, FAULT 2-08 is declared if the DC plate voltage is greater than 100 volts. The 1 KW LPA is put into OPERATE. If the DC plate voltage is not between 2000 and 5000 volts, FAULT 2-09 is

declared. If the plate current is greater than 5 mA, FAULT 2-10 is declared.

8. Bias Test. The power amplifier bias is turned on (the LPA is keyed without RF drive). If the plate current is not between 20 and 150 mA, FAULT 2-11 is declared.

9. Keying Test. An RF MUTE message is sent to the 100 Watt Transceiver. If the RF input signal level is not below 6 watts in 200 milliseconds, FAULT 2-12 is declared. If the RF input falls below 6 watts, the T/R relay is keyed and the RF MUTE signal is removed. Tune Power Request (TPR) and Transmit Gain Control Tune Power Request (TGC TPR) messages are sent to the 100 Watt Transceiver. The message "rF" is sent to the METER LCD display to let the operator know that RF input power is required to complete the test. This message remains until the RF input signal level is greater than 5 watts. If the RF input signal is not greater than 5 watts in 20 seconds, FAULT 2-13 is declared. If the RF input signal level is sufficient, the power amplifier plate current is checked. If the power amplifier plate current is not between 325 mA and 480 mA, FAULT 2-14 is declared. The DC plate voltage is checked again at this point; and if it is not within the previously specified limits for the OPERATE mode (2000 to 5000 Vdc), FAULT 2-09 is declared.

10. Tuning Test. A TGC Lock command is sent to the 100 Watt Transceiver. Using the auto-tuning software, the coil is moved toward MIN L while searching for a tune peak. If no tune peak is found, FAULT 2-15 is declared. When the tune peak is found, forward power is checked. If the forward power is not between 100 watts and 400 watts, FAULT 2-16 is declared. If the forward power is normal, the VSWR is checked. If the VSWR is not less than 2.25:1, FAULT 2-17 is declared. If the VSWR is normal, the ratio of forward power to RF

T.O. 31R2-2URC-121

input power is checked. This ratio must be between 5 and 60. If not, FAULT 2-18 is declared. Tune Power Request Off, TGC Tune Power Request Off, and TGC Lock Off commands are sent to the 100 Watt Transceiver when this part of the test is completed.

11. Transceiver Serial Link Test. As in normal operation, certain failures in the serial link to the transceiver during the BIT test cause FAULT 2-21 to be declared.

12. Test Completion.

- (a) The BIT tests described in the above paragraphs are continued until a fault is encountered. When a fault is flagged, all further testing is aborted.
- (1) If the BIT test was initiated from the 100 Watt Transceiver, the fault code is displayed on the transceiver LCD display. The fault code will also appear on the LPA's LCD display if the METER selector switch is placed in the STATUS/FAULT position. The fault code may be cleared by commanding the LPA to OPERATE from the 100 Watt Transceiver or by moving the METER selector switch out of the STATUS/FAULT position.
- (2) If the BIT test was initiated from the LPA, the fault code is displayed on the LPA's

front panel meter. The fault code will also appear on the transceiver's LCD display if "2ND," "TEST" is pressed. To remove the LPA from the test mode, the METER selector switch must be moved out of the STATUS/FAULT position. The fault code may be cleared by commanding the LPA to OPERATE from the 100 Watt Transceiver (if the LPA is placed back in AUTO) or by moving the METER selector switch to the STATUS/FAULT position and then out again.

- (b) If no fault is encountered during any of the tests, the following occurs:
 - (1) If the BIT test was initiated from the 100 Watt Transceiver, the message "PASSEd" is displayed on the transceiver front panel for 5 seconds; and the LPA front panel returns immediately to its normal operating mode.
 - (2) If the BIT test was initiated from the LPA, the message "PASS" is displayed on the meter. The message will remain there as long as the METER selector switch is in the STATUS/FAULT position. When the selector switch is moved out of the STATUS/FAULT position, the message disappears and the LPA front panel returns to its normal operating mode.

CHAPTER 7

ILLUSTRATED PARTS BREAKDOWN

Section I. INTRODUCTION

7-1. PURPOSE. This chapter lists, illustrates, and describes the assemblies and detail parts for the 1 KW LPA. Its purpose is for the identification, requisitioning, and issuance of parts at the organizational (on-equipment) level.

7-2. SCOPE. Only parts that are coded as replaceable at the organizational level are listed in this chapter. These include the major assemblies and a few detail parts. Mounting hardware is listed only if it is used to attach a replaceable assembly or detail part and only if it is not held captive to the assembly or part. In general, the assemblies and parts installed at the time the 1 KW LPA was manufactured are listed and identified in this chapter. When an assembly or part (including vendor items), which is different from the original, was installed during the manufacture of later items, series, or blocks, all assemblies and parts are listed (and "Usable-On" coded). However, when the original assembly or part does not have continued application (no spares of the original were procured or such spares are no longer authorized for replacement), only the preferred assembly or part is listed. Also, when an assembly or part was installed during modification, and the original does not have continued application, only the preferred item is listed. Interchangeable and substitute assemblies and parts, subsequently authorized by the Government, are not listed in this chapter; such items are identified by information available through the Interchangeable and Substitute (I & S) Data Systems. Refer to T.O. 00-25-184. When a standard size part

can be replaced with an oversize or undersize part, the latter parts, showing sizes, are also listed. Repair Parts kits and Quick Change Units are listed when they are available for replacement.

7-3. CHAPTER ORGANIZATION. This chapter is divided into two sections. Section I, Introduction, explains the purpose, scope, and organization of the chapter. Section II, MAINTENANCE PARTS LIST, consists of illustrations, in which the assemblies and detail parts of the 1 KW LPA are identified by numbers (called index numbers), followed by a list which contains parts numbers descriptions, and other relevant data for the items identified on the illustrations.

7-4 SOURCE, MAINTENANCE, AND RECOVERABILITY (SMR) CODES. This chapter contains Air Force Peculiar In-Being Source and Repair Codes only. Definitions of these SMR codes, as well as detailed coding criteria and transpositions matrices for each coding method may be obtained from T.O. 00-25-195. Refer to page 7-3.

7-5. FEDERAL SUPPLY CODES FOR MANUFACTURERS (FSCM). The codes used in this chapter are as follows. The first list is in numerical order by FSCM; the second is in alphabetical order by manufacturer name.

Note: Field and organizational maintenance of the modules and circuit card assemblies is limited only to the removals, replacements, and alignments given in chapter 6.

JOINT MILITARY SERVICES UNIFORM SMR CODING MATRIX T.O. 00-25-195

SOURCE		USE			MAINTENANCE REPAIR		RECOVERABILITY		ERRC CODE
1st Position	2nd Position	3rd Position	4th Position	5th Position	6th Position				
P Procurable	A Stocked	O Remove/ Replace at Organizational Level	Z No Repair	Z Nonreparable Condemn at 3rd Position Level	N Nonrecoverable XB3 Condemn at Any Level				
	B Insurance								
	C Deteriorative								
	E Support Equipment, Stocked								
	F Support Equipment, Nonstocked								
	G Sustained Life Support								
K Component of a Repair Kit	F Intermediate Kit	F Remove/ Replace at Inter- mediate Level	O Repair at Organizational	F Reparable Condemn at Intermediate	C Recoverable XD1 (SCARS) Condemn at Depot				
	D Depot Kit								
	B In Both Kits								
	O Organization								
M Manufacture	F Intermediate		F Repair at Intermediate						
	D Depot								
	O Organization								
	F Intermediate								
A Assemble	D Depot	D Remove/Replace at Depot Level	D Limited Repair at O or F Level	D Reparable Condemn at Depot					
	O Organization								
	F Intermediate								
	D Depot								
X Nonprocured	A Requisition NHA		L Repair at Depot	A Special Handling					
	B Reclamation from IM								
	C Mfg Drawings								

Section II. MAINTENANCE PARTS LIST

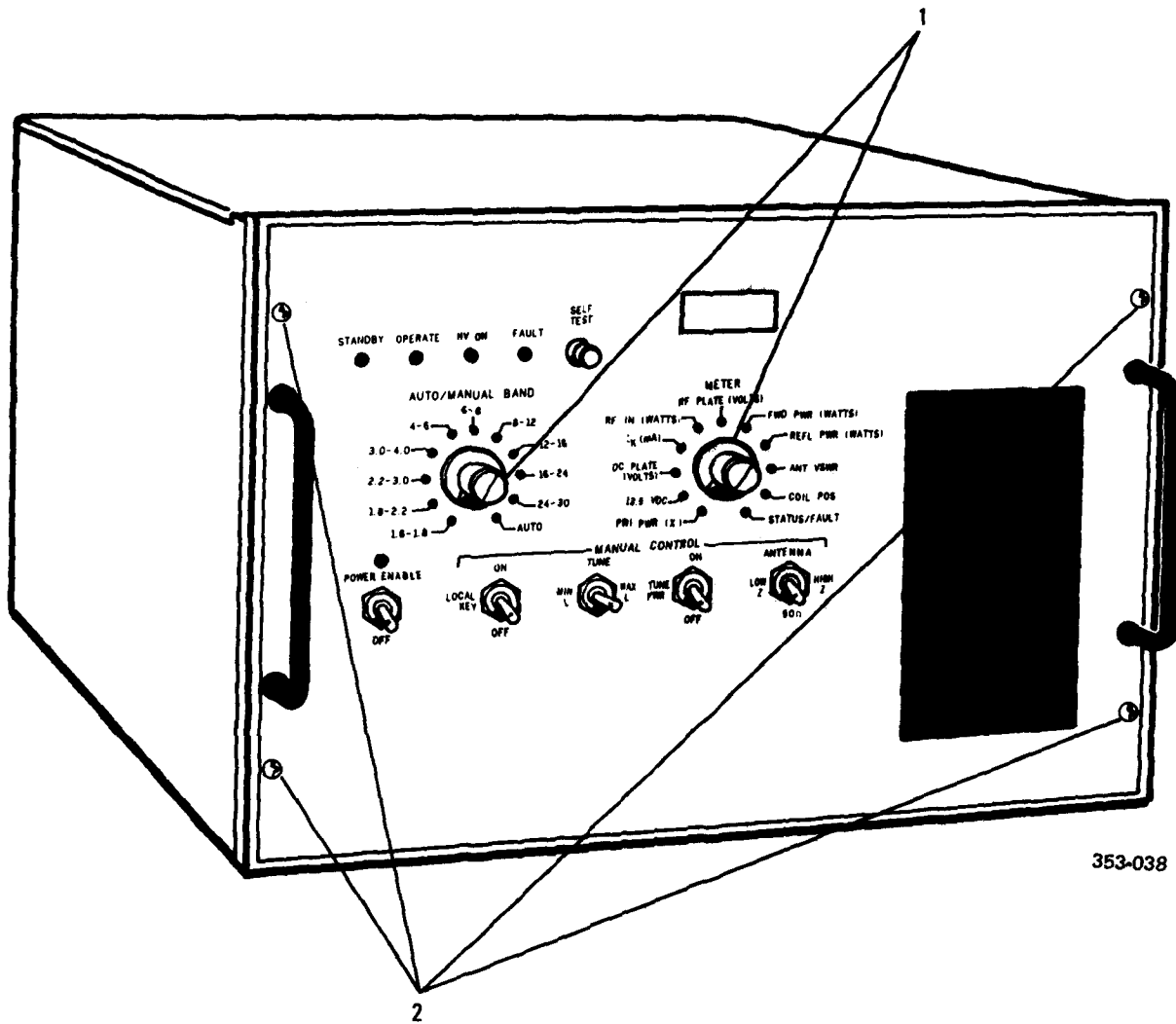

Figure 7-1. 1 KW LPA, AM-7224/URC, Front View

ILLUSTRATED PARTS BREAKDOWN

Fig. & Index No.	Part No.	FSCM	Description 1 2 3 4 5 6 7	Units Per Assy	Usable On Code	SMR Code
7-1-1 2	MS91528-1F1B AN565DC4L4 10087-2012 10087-2011	96906 88044 14304 14304	Knob . Screw, Set (AP) Screw, Machine Washer, Flat	2 4 4 4		PAOZZ PAOZZ XB XB

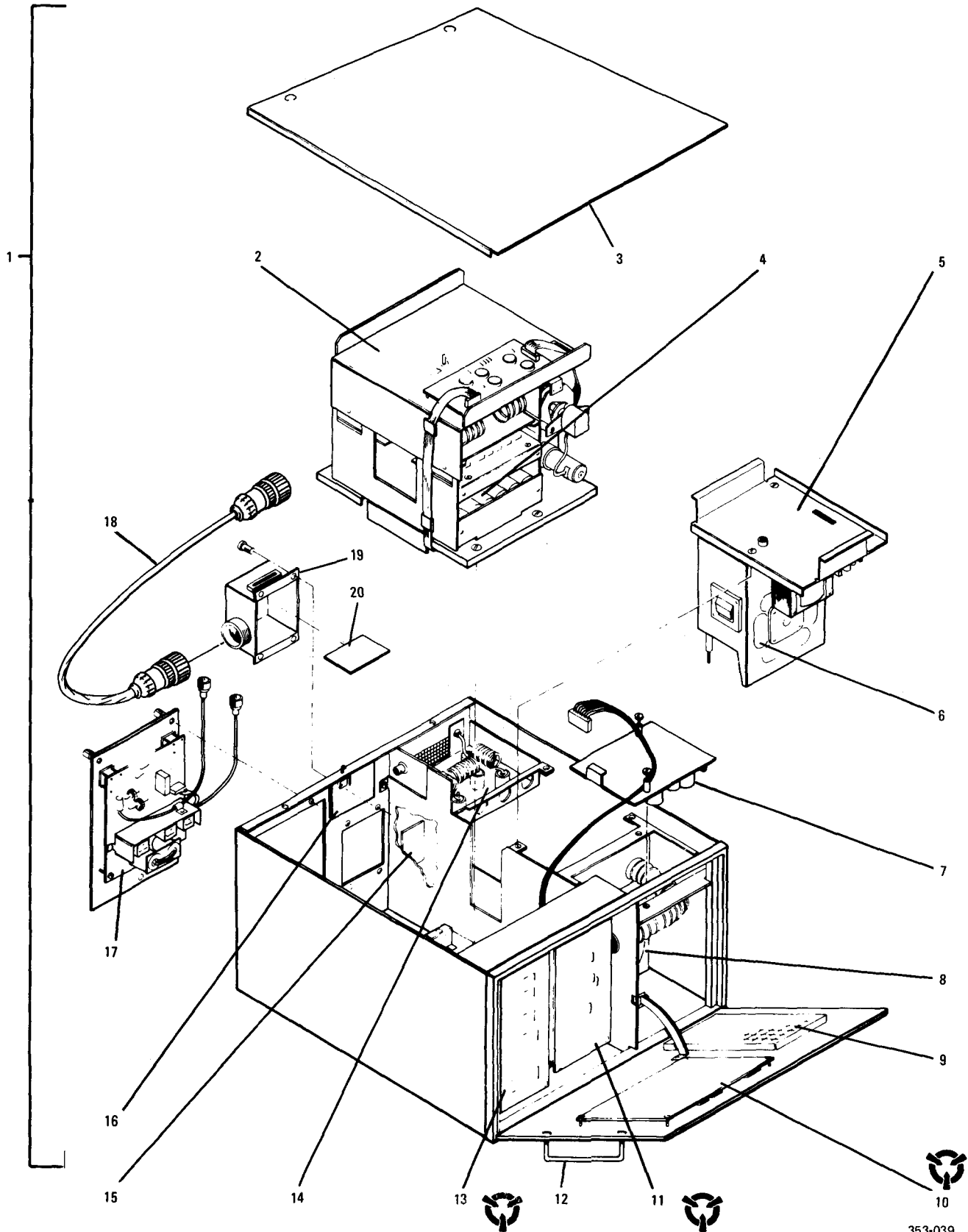

Figure 7-2. 1 KW LPA, AM-7224/URC, Exploded View

353-039

ILLUSTRATED PARTS BREAKDOWN

Fig. & Index No.	Part No.	FSCM	Description 1 2 3 4 5 6 7	Units Per Assy	Usable On Code	SMR Code
7-2-	10087-0000	14304	Amplifier, RF *			PEODD
1	10087-3100	14304	. Amplifier, RF	1		XB
2	10087-3700	14304	. . Tank Assy, A2	1		PAODD
3	10087-3104	14304	. . Cover	1		XB
	AJ4-35-SS	32039	. . Stud	2		XB
	SR4	72794	. . Retainer	2		PAOZZ
4	10087-3745	14304	. . Tune Cap. PWB Assy, A2A1A1 and A2A2A1	2		PAOZZ
	MS51957-27	96906	. . Screw, Machine (AP)	10		PAOZZ
	MS35333-71	96906	. . Washer, Lock (AP)	10		PAOZZ
5	10087-3200	14304	. . Electron Tube Assy, A1	1		PAODD
6	8877/3CX1500A7	06980	. . Tube, Electron	1		PAOZZ
7	10087-1500	14304	. . Fan Inverter PWB Assy, A4	1		PAOLD
8	10086-1400	14304	. . Fan Assy	1		PAOZZ
	MS51957-31	96906	. . Screw, Machine (AP)	4		PAOZZ
	MS115795-806	96906	. . Washer, Flat (AP)	4		PAOZZ
	MS35338-136	96906	. . Washer, Lock (AP)	4		PAOZZ
9	10087-2010	14304	. . Filter, Air	1		XB
10	10087-2100	14304	. . Front Panel PWB Assy, A7	1		PAODD
11	10086-7100	14304	. . Power Control PWB Assy, A5	1		PAODD
12	A1013-29	06540	. . Handle	2		XB
	16022-A2	06540	. . Bushing	4		XB
	MS24693-C272	96906	. . Screw	4		PAOZZ
13	10086-9200	14304	. . Micro Control PWB Assy, A6	1		PAODD
14	10087-4500	14304	. . Low Pass Filter Assy, A10	1		PAOLD
	MS51957-14	96906	. . Screw, Machine (AP)	2		PAOZZ
	MS35338-135	96906	. . Washer, Lock (AP)	2		PAOZZ
	MS51957-27	96906	. . Screw, Machine (AP)	4		PAOZZ
15	10086-7200	14304	. . Thermal Sensor PWB Assy, A8	1		PAODD
	MS51957-14	96906	. . Screw, Machine (AP)	2		PAOZZ
	MS35338-135	96906	. . Washer, Lock (AP)	2		PAOZZ
	MS15795-804	96906	. . Washer, Flat (AP)	2		PAOZZ
16	10087-3140	14304	. . Interconnect PWB Assy, A9	1		PAOLD
	MS16106-4	96906	. . Switch, Interlock	1		PAOZZ
	MS51958-13	96906	. . Screw, Machine (AP)	2		PAOZZ
	MS35338-135	96906	. . Washer, Lock (AP)	2		PAOZZ
17	10087-4600	14304	. . VSWR/XFMR PWB Assy, A3	1		PAODD
18	10087-0015	14304	. . Cable Assy, RF	1		MDO
19	10087-3109	14304	. . Cover	1		XB
	MS51957-28	96906	. . Screw, Machine	8		PAOZZ
	MS35338-136	96906	. . Washer, Lock	4		PAOZZ
	MS15795-805	96906	. . Washer, Flat	4		PAOZZ
	H6768	14304	. . Nut, Clinch	5		PAOZZ
20	10087-3170	14304	. . Connector PWB Assy, A11	1		PAOZZ

*Installation includes Ancillary Kit 10087-0060 (See Figure 7-3)

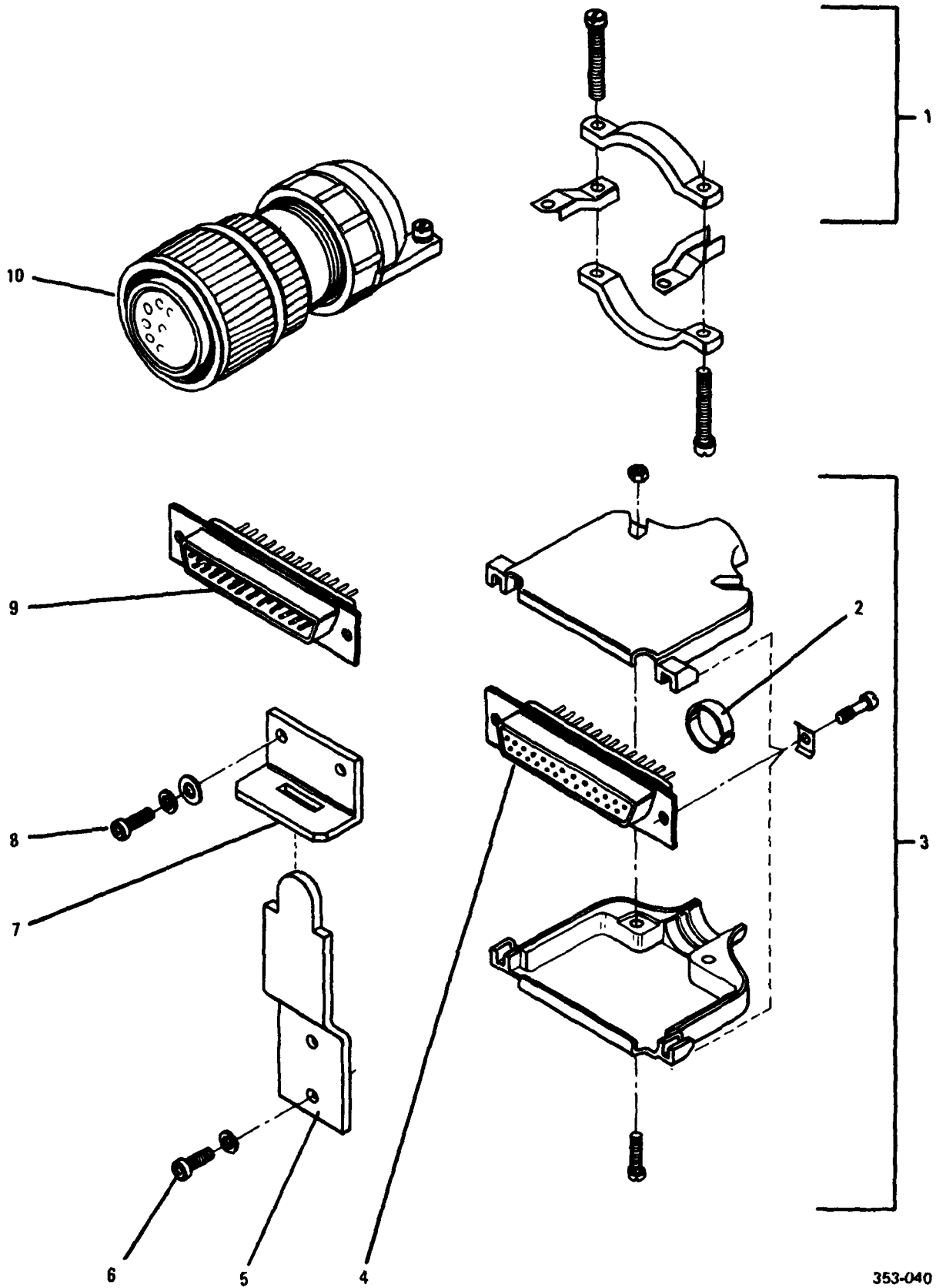

Figure 7-3. Installation Kit for 1 KW LPA

353-040

ILLUSTRATED PARTS BREAKDOWN

Fig. & Index No.	Part No.	FSCM	Description 1 2 3 4 5 6 7	Units Per Assy	Usable On Code	SMR Code
7-3-	10087-0060	14304	Installation Kit	1		XB
1	10-36233-243	77820	. Retainer	2		XB
2	745508-8	00779	. Bushing	1		XB
3	745173-2	00779	. Cover, Conn.	1		PAOZZ
4	17-80250-16	74868	. Connector, Rcpt.,Elec.	1		PAOZZ
5	10087-3107	14304	. Bracket, Angle	8		XB
6	MS51957-30	96906	. Screw, Machine	16		PAOZZ
7	10087-3106	14304	. Bracket, Angle	4		XB
8	MS51957-17	96906	. Screw, Machine	8		PAOZZ
9	DBM25P	71468	. Connector, Rcpt., Elec.	1		PAOZZ
10	10-109628-18S	77820	. Connector, Rcpt., Elec.	1		PAOZZ

REFERENCE DESIGNATOR INDEX

Reference Designator	Figure & Index No.	Part Number
A1	7-2-5	10087-3200
A2	7-2-2	10087-3700
A2A1A1, A2A2A1	7-2-4	10087-3745
A3	7-2-17	10087-4600
A4	7-2-7	10087-1500
A5	7-2-11	10086-7100
A6	7-2-13	10086-9200
A7	7-2-10	10087-2100
A8	7-2-15	10086-7200
A9	7-2-16	10087-3140
A9S1	7-2-16	MS16106-4
A10	7-2-14	10087-4500
A11	7-2-20	10087-3170
B1	7-2-8	10086-1400



FACSIMILE (FAX) MESSAGE

HARRIS RF COMMUNICATIONS GROUP
1680 UNIVERSITY AVENUE
ROCHESTER, NEW YORK 14610 USA
FACSIMILE NUMBERS (716) 242-1735
TELEPHONE NUMBERS (716) 244-5830 [s/b]
(716) 242-3269 [direct]
E-Mail: JGainer@harris.com [direct]

DATE: 6/11/98
TO: Don Poquette
FACSIMILE NO.: (406) 731-~~469T~~ 7133
FROM: Jon Gainer
SUBJECT: Coil Drive install Cautions. Manual tune chart.

This fax consists of 4 page (s) not including this cover sheet. If you have any problems recovering all/part of this message, please call and I will assist you.

Don,

Here's the information. If you need further assistance or have other questions please call.

Regards.

Jon Gainer

Sr. Technical Representative

Customer Service

Coil Drive Assembly Installation Cautions

10086-3720

This information is presented to assist the technician when performing a Coil Drive Assembly replacement. Please read this entire page before you begin to get a "feel" for what all must be done. Make sure that all primary power is removed from the equipment prior to doing anything.

1. Before starting to remove the old unit insure that the associated coil is positioned so that the roller is one fourth of a turn from the end of the coil towards the Coil Drive Assembly (10086-3720). If your unit is broken do this manually. This MUST be done before removing the Coil Drive Assembly or the Bandswitch will be misaligned causing damage to the amplifier.
2. After the above is accomplished, unscrew the hardware securing the assembly into place and remove the flex cable from the SOFTPOT and the PITTMAN motor. The cap on the PITTMAN motor must be unsoldered from the old assembly and used on the new assembly. The Limit Switch will be removed from the old assembly via the hardware and not unsoldered. The coupling attached to the belt driven pulley must be loosened before the Coil Drive Assembly can be freed from the unit.
3. The best way to insure that the new assembly will be setup correctly is to manually rotate the cam on the big white gear to the very top of the assembly. Do this holding the assembly horizontally with the SOFTPOT up, looking at the label on the SOFTPOT and turning the black coupling connected directly to the SOFTPOT. Then move the cam clockwise just enough to clear the way for the Limit Switch to fit into place and install the Limit Switch.
4. After the Limit Switch is installed move the cam on the white gear counterclockwise until the Limit Switch just accuates. The assembly is now correctly positioned and can be installed. Connect the coupling to the coil, the flex cable and the PITTMAN motor cap. Install all hardware and check for tightness and wire dress.
5. When you are satisfied that everything is correct, reconnect primary power and make sure that the coil has free travel from one end to the other and that the bandswitch is correct.
6. If you have any questions please feel free to call us here at the Product Service Department. Telephone : (716) 244-5830
Ext: 3569

- c. Check that all LPA front panel LEDs come on and that all LCD segments on the meter display are on.
 - (1) A "PASSEd" message on the Transceiver's display indicates that the BIT (Built-In-Test) has been passed.
 - (2) A fault code (2-01 through 2-22) on the Transceiver's display indicates that a part of the test has failed. (The fault code will also appear on the LPA's LCD display if the METER selector switch is moved to the STATUS/FAULT position). All further testing is stopped. Refer to table 6-3 (in chapter 6) for an explanation of the fault codes.
 - (3) The fault code may be cleared by commanding the LPA to OPERATE from the Transceiver or by moving the LPA's METER selector switch out of the STATUS/FAULT position.
 - (4) If all indications are normal, proceed to the next paragraph.

3-6 INITIAL CHECKOUT

In the initial checkout the RF-353 Linear Power Amplifier is checked for readiness through the use of the front panel controls and indicators. The checkout procedure should be conducted immediately after performing the initial power application. This sequence does not cover each feature of the LPA, only those necessary to prove normal performance. Refer to chapter 4, Operation, for complete operation information. Features related to the use of companion equipment are not discussed. This sequence assumes the initial power application procedure has been performed.

3-7 STEP-BY-STEP SEQUENCE FOR MANUAL TUNING PROCEDURE

NOTE

If an RF-601A Antenna Coupler is used, it must be tuned prior to performing this procedure. This can be done by keying the Transceiver with the LPA in STANDBY. After the RF-601A has tuned, place it in manual and then perform the paragraph 3.7 procedure. Return the RF-601A to AUTOMATIC upon completion of the procedure. Generally, the RF-601A should be tuned on a frequency greater than 5 MHz.

- a. Set the associated RF-350K Transceiver to the desired frequency.
- b. Select the band corresponding to the associated Transceiver frequency using the AUTO/MANUAL BAND switch.
- c. Set the ANTENNA switch to the center position (50 OHMS).
- d. Set the METER selector switch to the COIL POS position.
- e. Using the spring-loaded TUNE control, pre-position the coil to the value indicated on the Manual Tune Chart, figure 3-1, for the frequency selected on the Transceiver. Move the TUNE control toward MIN L or MAX L until the number on the LCD display matches the number on the chart.
- f. Set the METER switch to the FWD PWR (WATTS) position or to the RF Plate (volts) position.

- g. When the bandswitch is finished tuning the bandswitch wafer, set the MANUAL TUNE PWR switch to the ON position. When this is done, a TUNE POWER REQUEST message is sent to the XCVR and the LPA is keyed. If a fault is detected while this switch is active, the LPA will drop back to STANDBY and the MANUAL TUNE PWR switch must be turned OFF before the fault can be cleared.
- h. Observing the METER display, use the TUNE switch to tune the servo coil to the maximum rf output or rf plate volts by switching to MIN L or MAX L.
- i. Turn off the MANUAL TUNE PWR switch.

NOTE

Turning off the TUNE PWR switch notifies the Transceiver that the LPA is tuned, whether it actually is or not. Therefore, before you turn this switch off, make sure that you have correctly tuned the LPA. Otherwise, there is the possibility of a severe mismatch between the LPA and the antenna system, resulting in low forward power or a forward power fault.

- j. Set the MANUAL LOCAL KEY switch to the ON position. The LPA should go to the OPERATE condition and the OPERATE indicator should come on steady.

~~3-8 STEP-BY-STEP SEQUENCE FOR AUTOMATIC TUNING PROCEDURE~~

- a. ~~Set the LOCAL KEY switch to OFF, and set the AUTO/MANUAL BAND select switch to the AUTO position. This deactivates all of the manual tune switches. On the RF-350K Transceiver front panel, using the [2ND], [STB/OPR] keypad controls puts the 1 KW LPA in OPERATE.~~
- b. ~~Select a different frequency band at the companion Transceiver, and key the Transceiver. The LPA should tune to the new frequency in 10 seconds or less. If not, there is a problem in the LPA.~~
- c. ~~This completes the initial checkout procedure. If any problems were encountered during this procedure, refer to chapter 6, Maintenance.~~

Section 2 - PREPARATION FOR RESHIPMENT

3-9 PREPARATION FOR RESHIPMENT

This portion of the manual contains step-by-step procedures for disassembly and repacking the RF-353 Linear Power Amplifier for reshipment.

3-10 STEP-BY-STEP DISASSEMBLY PROCEDURE

- a. Ensure that all power sources associated with the RF-353 Linear Power Amplifier and any interfacing companion equipment are shut down.
- b. Disconnect all interface cables, power cables, and grounding straps connected to the LPA.
- c. Carefully remove the LPA from the stack mounted or rack mounted system configuration.

RF-353
PREPARATION FOR USE AND RESHIPMENT

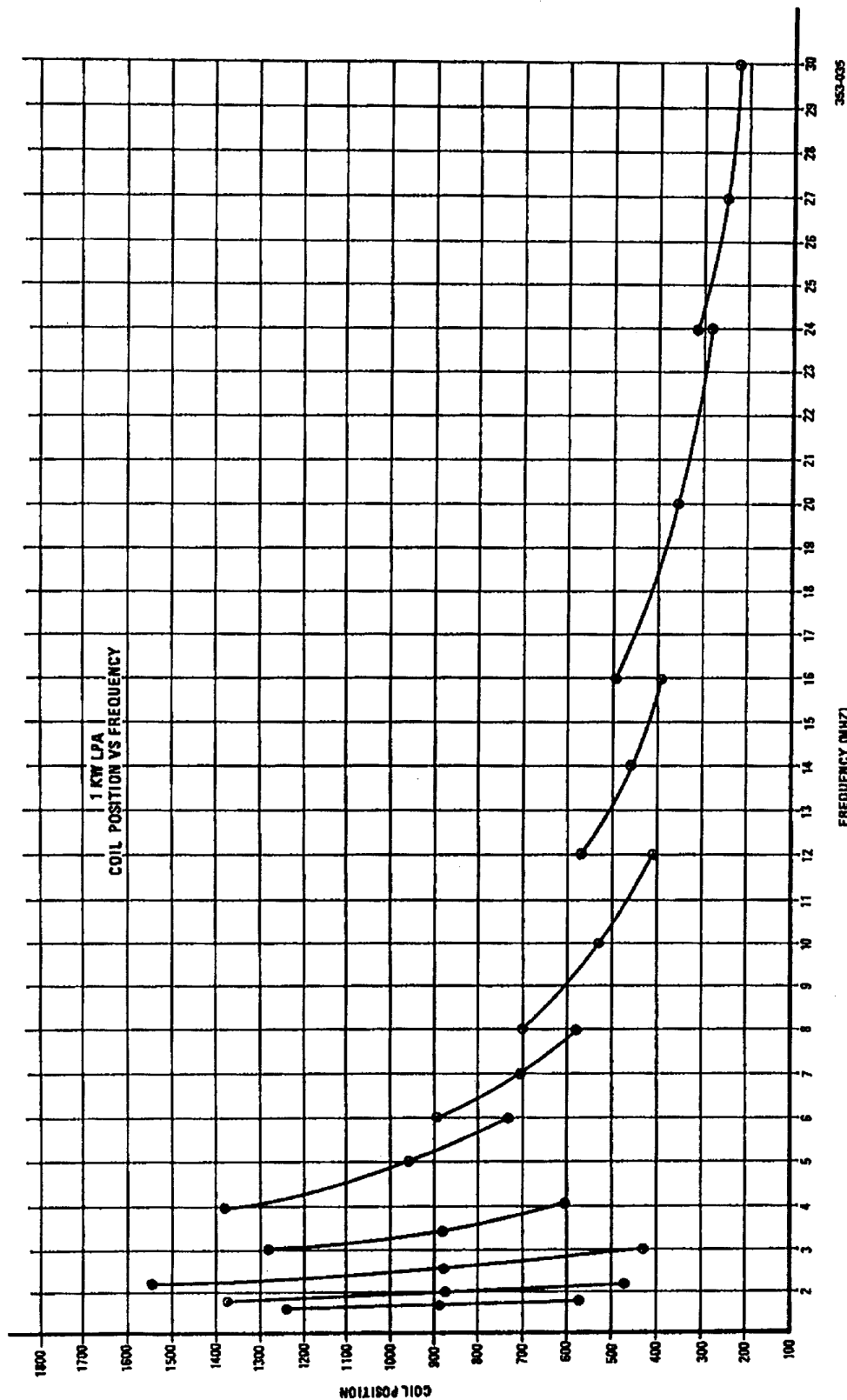

Figure 3-1. Manual Tune Chart

CHAPTER 8
FOLDOUT DRAWINGS

LIST OF 100/500 WATT ANTENNA COUPLER FOLDOUT DRAWINGS.

- FO-1 Family Tree 100/500 Watt Antenna Coupler
- FO-2 100/500W Coupler Functional Block Diagram
- FO-3 Component Location Diagram
- FO-4 Antenna Coupler Interconnection Diagram

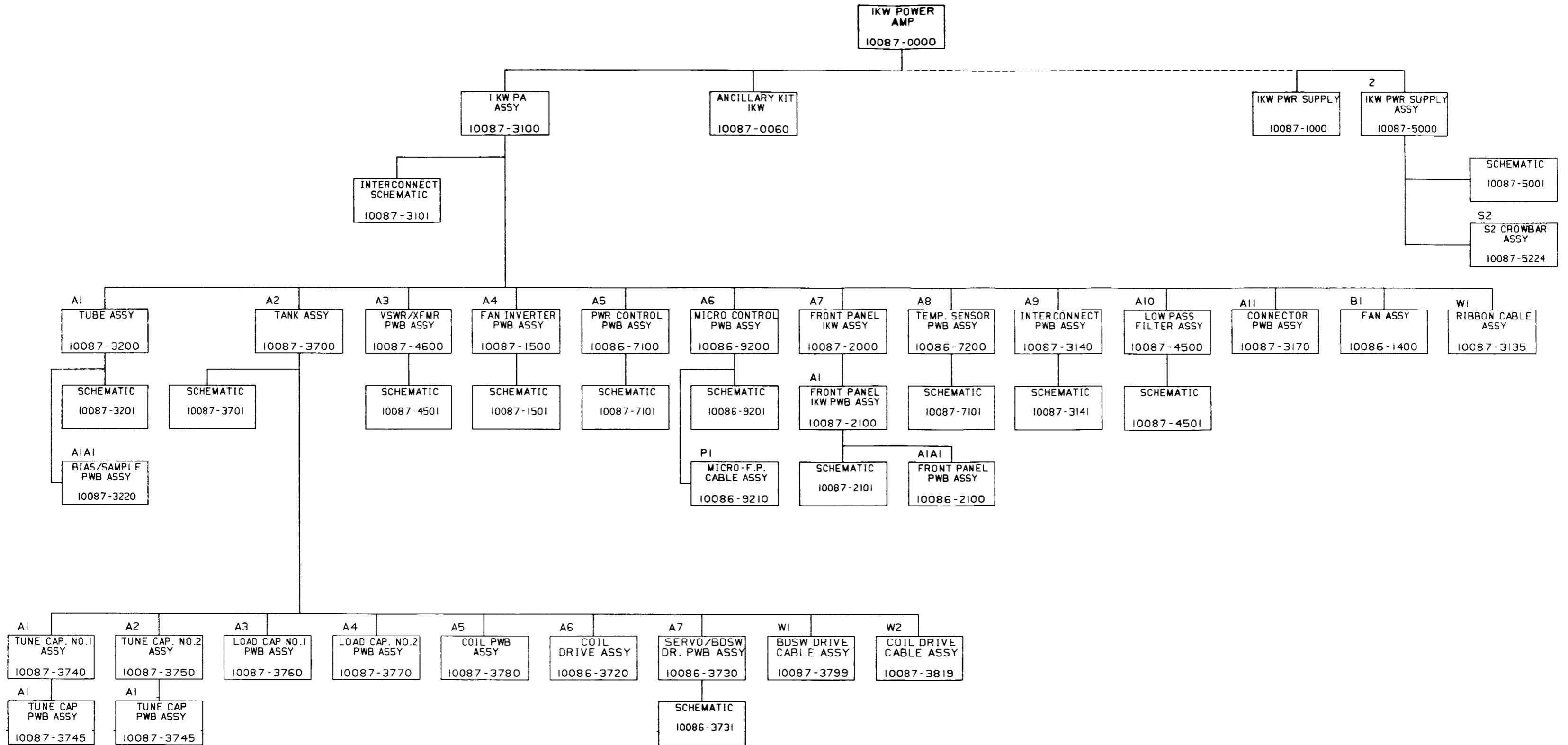
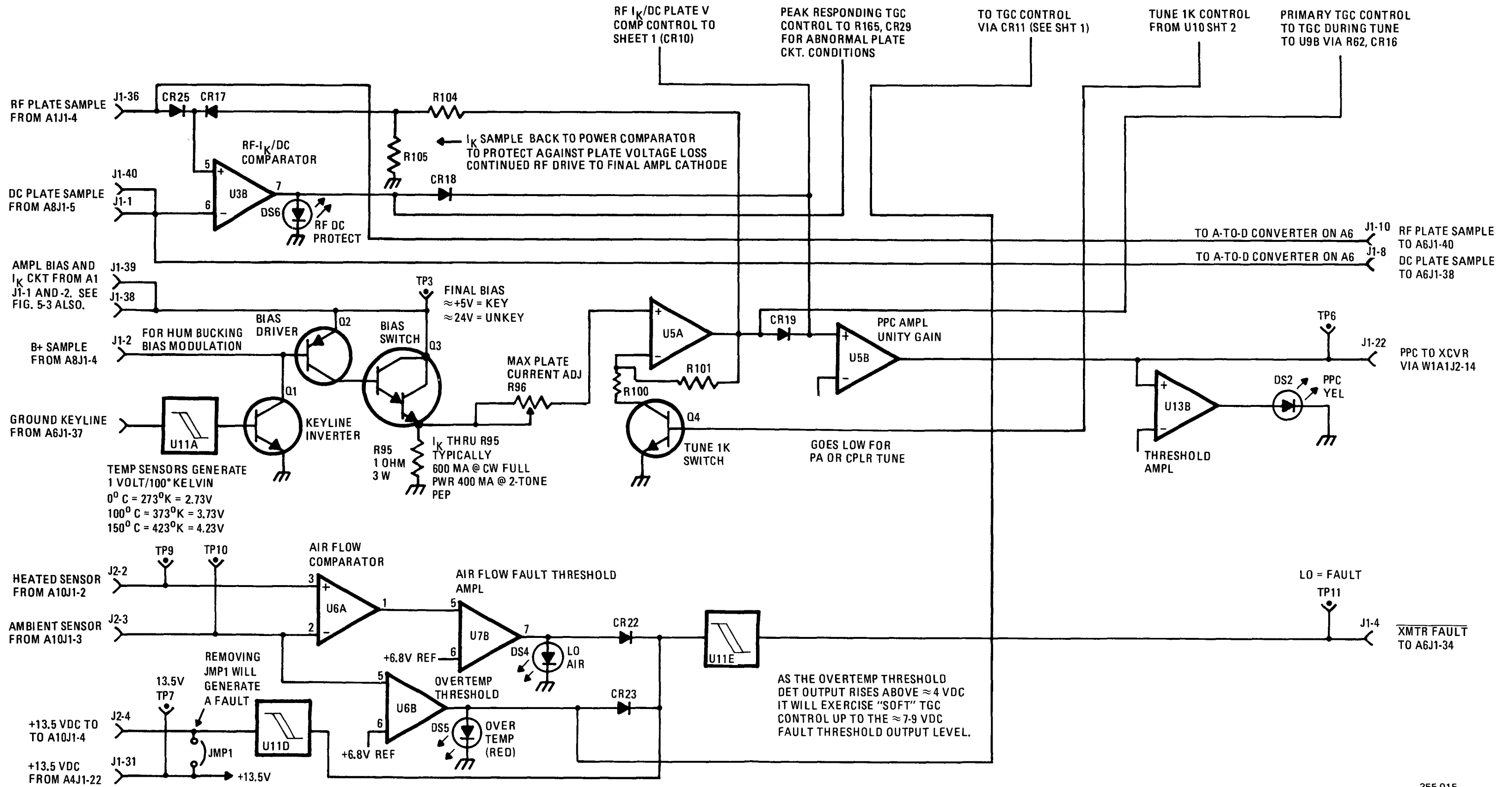

Figure FO-1. Family Tree 1 KW LPA



355-015

Figure FO-2. Power Control PWB Simplified (Sheet 2 of 2)
FP-5/(FP-6 Blank)

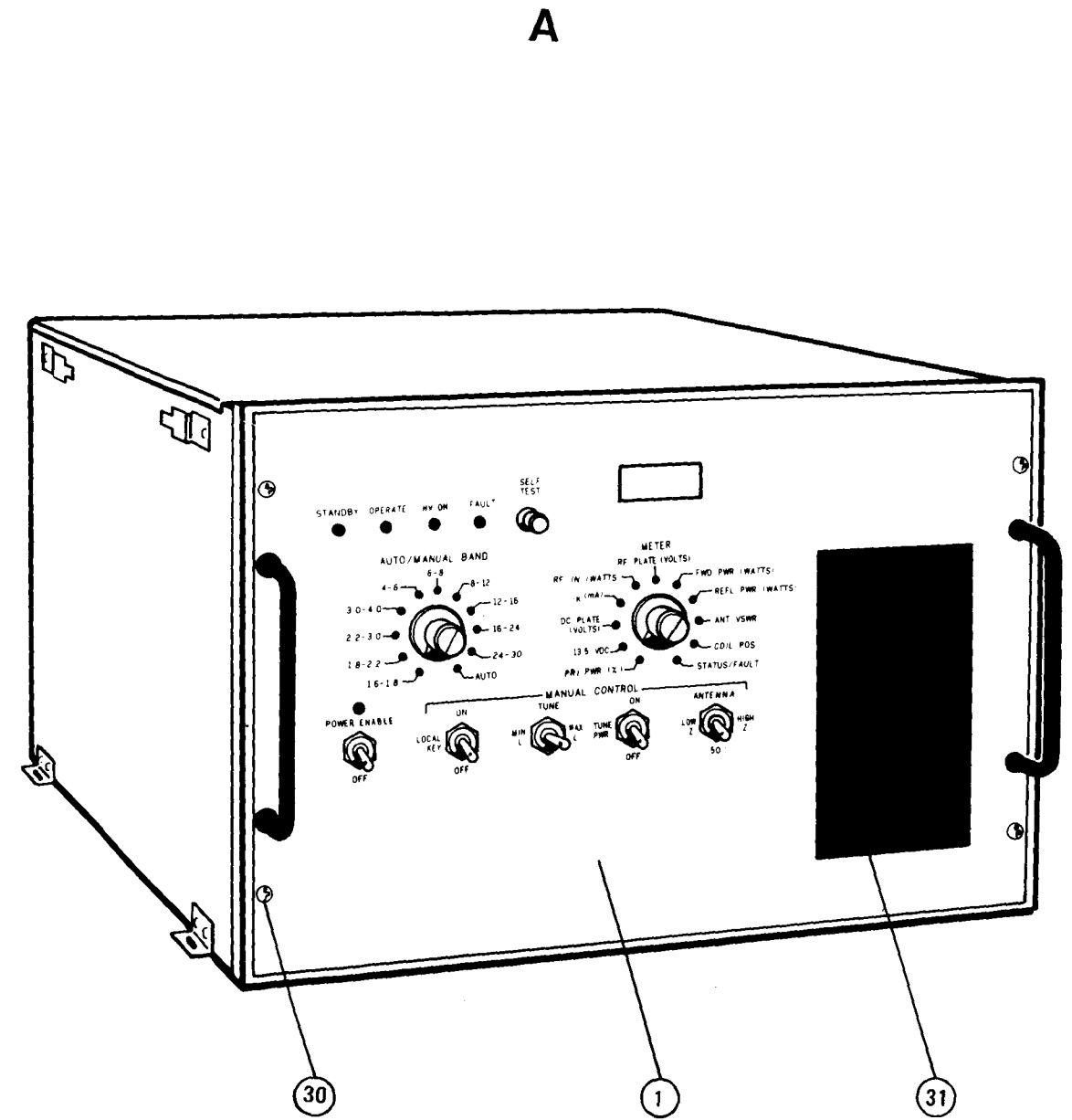
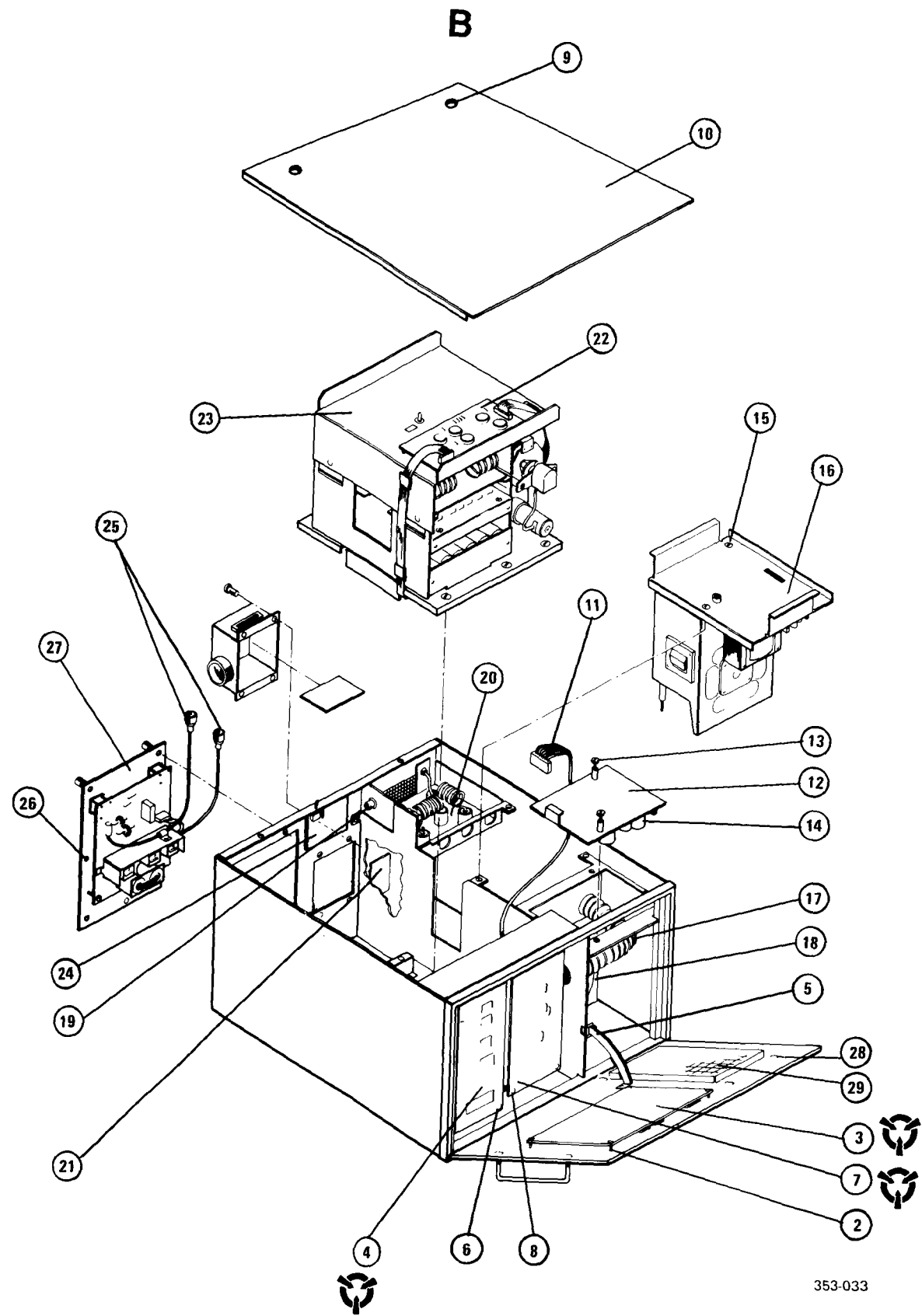

Figure FO-3. Component Location Diagram
FP-7/(FP-8 Blank)

NOTE: UNLESS OTHERWISE SPECIFIED:

1. PARTIAL REFERENCE DESIGNATIONS ARE SHOWN FOR DETAIL PARTS. PREFIX THESE WITH UNIT NO. AND/OR ASSEMBLY DESIGNATIONS SHOWN ON DRAWING TO OBTAIN COMPLETE DESIGNATIONS.
2. ALL RESISTOR VALUES ARE IN OHMS, 1/4W, ±5%.
3. ALL CAPACITOR VALUES ARE IN MICROFARADS (UF).
4. ALL INDUCTANCE VALUES ARE IN MILLIHENRIES (MH).
5. VENDOR PART NO. CALLOUTS ARE FOR REFERENCE ONLY. COMPONENTS ARE SUPPLIED PER PART NO. IN PARTS LIST.
6. DC RESISTANCES OF INDUCTIVE ELEMENTS (CHOKES, COILS, MOTOR WINDINGS, ETC.) ARE LESS THAN 1 OHM.
7. PANEL DECALS ARE INDICATED BY BOLD TYPE IN A BOLD BOX, E.G., **ON/OFF**.
8. ALL RELAYS ARE SHOWN IN THE DE-ENERGIZED STATE.

HIGHEST REFERENCE DESIGNATION			
REFERENCE DESIGNATIONS NOT USED			

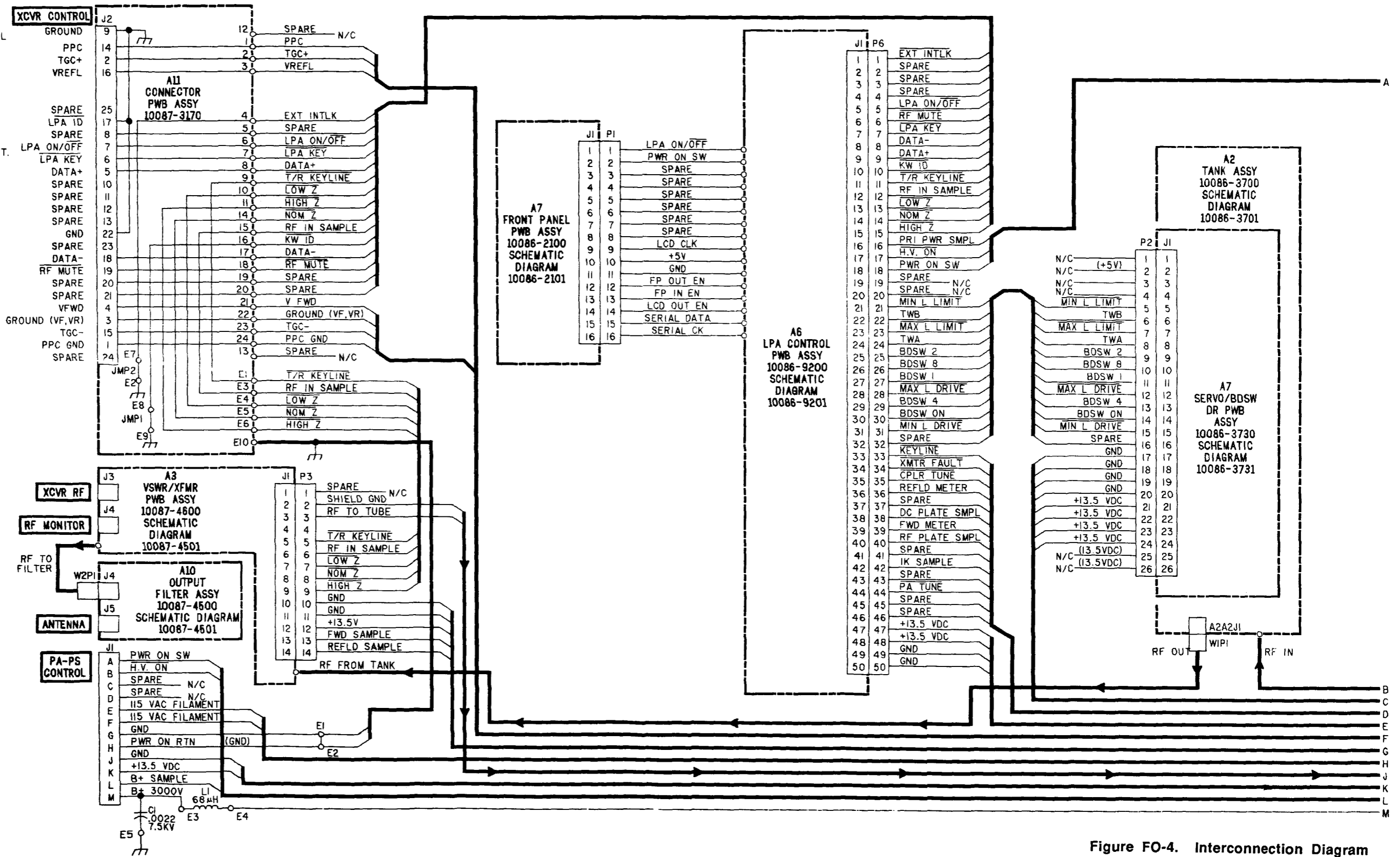

Figure FO-4. Interconnection Diagram (Sheet 1 of 2)

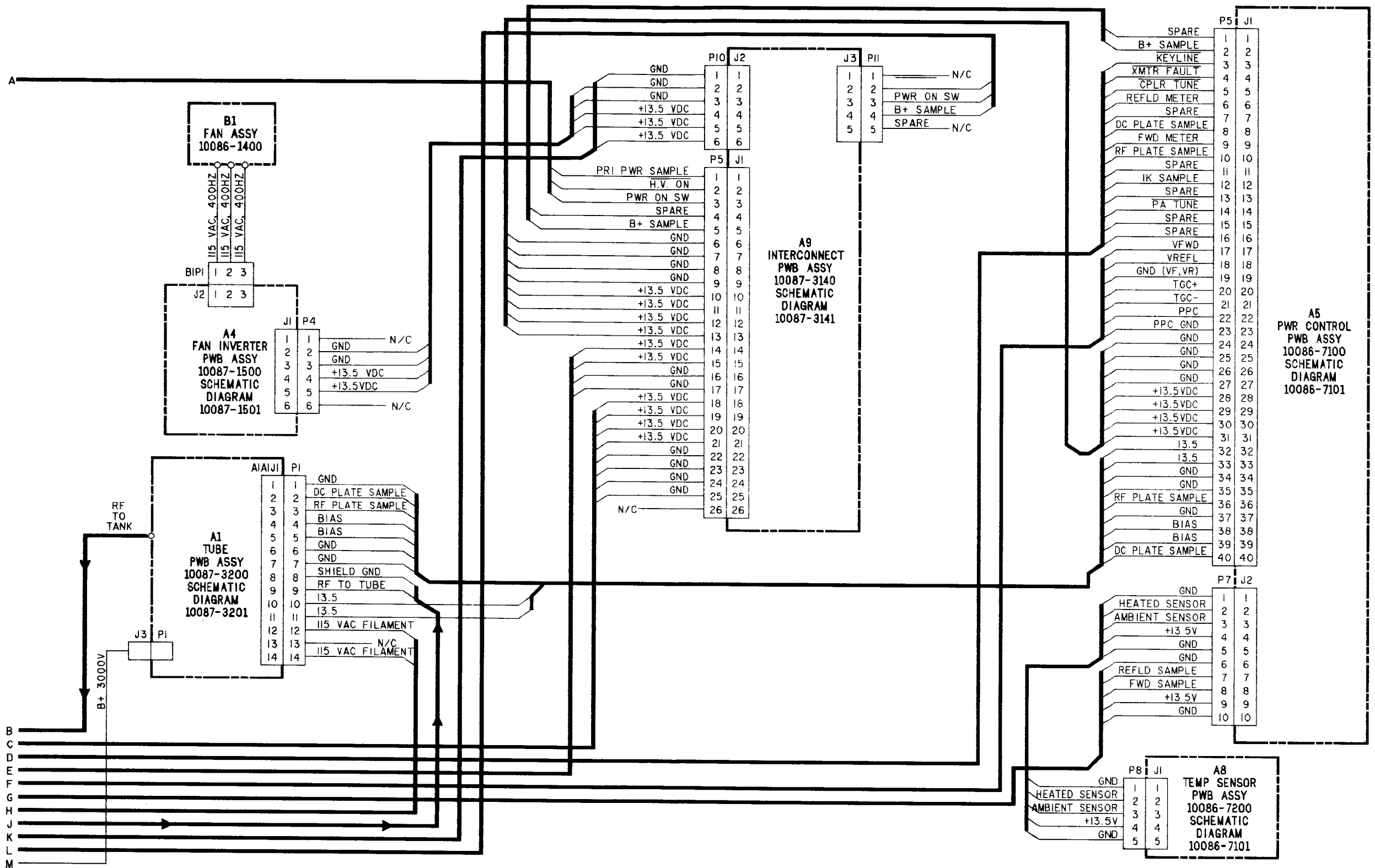

Figure FO-4 . Interconnection Diagram
(Sheet 2 of 2)